



Grandstream Networks, Inc.

UCM6510 IP PBX

User Manual



This page intentionally left blank

UCM6510 IP PBX User Manual

Index

CHANGE LOG	12
FIRMWARE VERSION 1.0.0.25	12
WELCOME	13
PRODUCT OVERVIEW	15
FEATURE HIGHLIGHTS	15
TECHNICAL SPECIFICATIONS	16
INSTALLATION	19
EQUIPMENT PACKAGING	19
CONNECT YOUR UCM6510	19
<i>CONNECT THE UCM6510</i>	19
SAFETY COMPLIANCES	21
WARRANTY	21
GETTING STARTED	23
USE THE LCD MENU	23
USE THE LED INDICATORS	25
USE THE WEB GUI	26
<i>ACCESS WEB GUI</i>	26
<i>WEB GUI CONFIGURATIONS</i>	27
<i>WEB GUI LANGUAGES</i>	27
<i>SAVE AND APPLY CHANGES</i>	28
MAKE YOUR FIRST CALL	29
SYSTEM SETTINGS	31
NETWORK SETTINGS	31
<i>BASIC SETTINGS</i>	31
<i>802.1X</i>	36
<i>STATIC ROUTES</i>	38
<i>PORT FORWARDING</i>	40
FIREWALL	42
<i>STATIC DEFENSE</i>	42
<i>DYNAMIC DEFENSE</i>	44
<i>FAIL2BAN</i>	46

CHANGE PASSWORD	46
LDAP SERVER.....	47
<i>LDAP SERVER CONFIGURATIONS</i>	47
<i>LDAP PHONEBOOK</i>	49
<i>LDAP CLIENT CONFIGURATIONS</i>	50
HTTP SERVER.....	52
EMAIL SETTINGS.....	53
TIME SETTINGS	55
<i>AUTO TIME UPDATING</i>	55
<i>SET TIME MANUALLY</i>	57
NTP SERVER.....	58
PROVISIONING	59
OVERVIEW	59
AUTO PROVISIONING	59
MANUAL PROVISIONING	62
<i>DISCOVERY</i>	62
<i>ASSIGNMENT</i>	63
<i>CREATE NEW DEVICE</i>	64
<i>PROVISIONING</i>	64
EXTENSIONS.....	65
CREATE NEW USER.....	65
<i>CREATE NEW SIP EXTENSION</i>	65
<i>CREATE NEW IAX EXTENSION</i>	68
<i>CREATE NEW FXS EXTENSION</i>	71
BATCH ADD EXTENSIONS	75
<i>BATCH ADD SIP EXTENSIONS</i>	75
<i>BATCH ADD IAX EXTENSIONS</i>	77
EDIT EXTENSION.....	80
EXPORT EXTENSIONS.....	81
IMPORT EXTENSIONS.....	81
EMAIL TO USER	82
ANALOG TRUNKS	85
ANALOG TRUNKS CONFIGURATION.....	85
PSTN DETECTION	87
ANALOG HARDWARE CONFIGURATION.....	91
DIGITAL TRUNKS	93
DIGITAL HARDWARE CONFIGURATION	93

DIGITAL TRUNK CONFIGURATION.....	102
DIRECT OUTWARD DIALING (DOD) VIA DIGITAL TRUNKS.....	103
DIGITAL TRUNK TROUBLESHOOTING	103
DATA TRUNK.....	105
VOIP TRUNKS	107
VOIP TRUNK CONFIGURATION.....	107
DIRECT OUTWARD DIALING (DOD) VIA VOIP TRUNKS.....	114
CALL ROUTES	117
OUTBOUND ROUTES.....	117
INBOUND ROUTES.....	119
<i>INBOUND RULE CONFIGURATIONS.....</i>	<i>119</i>
<i>BLACKLIST CONFIGURATIONS.....</i>	<i>122</i>
CONFERENCE BRIDGE.....	125
<i>CONFERENCE BRIDGE CONFIGURATIONS.....</i>	<i>125</i>
<i>JOIN A CONFERENCE CALL.....</i>	<i>127</i>
<i>INVITE OTHER PARTIES TO JOIN CONFERENCE.....</i>	<i>127</i>
<i>DURING THE CONFERENCE.....</i>	<i>128</i>
<i>RECORD CONFERENCE.....</i>	<i>129</i>
IVR	131
CONFIGURE IVR.....	131
CREATE IVR PROMPT.....	133
<i>RECORD NEW IVR PROMPT.....</i>	<i>133</i>
<i>UPLOAD IVR PROMPT.....</i>	<i>134</i>
LANGUAGE SETTINGS FOR VOICE PROMPT.....	135
DOWNLOAD AND INSTALL VOICE PROMPT PACKAGE.....	135
VOICEMAIL.....	139
CONFIGURE VOICEMAIL.....	139
ACCESS VOICEMAIL.....	140
VOICEMAIL EMAIL SETTINGS.....	141
CONFIGURE VOICEMAIL GROUP.....	143
RING GROUP.....	145
CONFIGURE RING GROUP.....	145

PAGING AND INTERCOM GROUP	147
CONFIGURE PAGING/INTERCOM GROUP	147
CALL QUEUE	149
CONFIGURE CALL QUEUE	149
EXTENSION GROUPS.....	153
CONFIGURE EXTENSION GROUPS	153
USE EXTENSION GROUPS.....	153
PICKUP GROUPS.....	155
CONFIGURE PICKUP GROUPS.....	155
MUSIC ON HOLD.....	157
FAX/T.38.....	159
CONFIGURE FAX/T.38	159
SAMPLE CONFIGURATION TO RECEIVE FAX FROM PSTN LINE	160
SAMPLE CONFIGURATION FOR FAX-TO-EMAIL	162
DISA.....	163
BLF AND EVENT LIST.....	165
BLF	165
EVENT LIST	165
DIAL BY NAME.....	169
DIAL BY NAME CONFIGURATION.....	169
CALL FEATURES	173
FEATURE CODES	173
CALL RECORDING.....	176
CALL PARK	177
<i>PARK A CALL</i>	<i>177</i>
<i>RETRIEVE THE PARKED CALL</i>	<i>177</i>
INTERNAL OPTIONS.....	179
INTERNAL OPTIONS/GENERAL	179
INTERNAL OPTIONS/JITTER BUFFER.....	181
INTERNAL OPTIONS/RTP SETTINGS	181

INTERNAL OPTIONS/STUN MONITOR.....	182
IAX SETTINGS.....	183
IAX SETTINGS/GENERAL.....	183
IAX SETTINGS/REGISTRATION.....	183
IAX SETTINGS/STATIC DEFENSE	184
SIP SETTINGS.....	187
SIP SETTINGS/GENERAL.....	187
SIP SETTINGS/MISC.....	188
SIP SETTINGS/SESSION TIMER.....	188
SIP SETTINGS/TCP and TLS	189
SIP SETTINGS/NAT	190
SIP SETTINGS/TOS.....	191
STATUS AND REPORTING	193
PBX STATUS.....	193
<i>TRUNKS</i>	193
<i>EXTENSIONS</i>	194
<i>QUEUES</i>	196
<i>CONFERENCE ROOMS</i>	197
<i>INTERFACES STATUS</i>	197
<i>DIGITAL CHANNELS STATUS</i>	199
<i>PARKING LOT</i>	200
SYSTEM STATUS	201
<i>GENERAL</i>	202
<i>NETWORK</i>	202
<i>STORAGE USAGE</i>	203
<i>RESOURCE USAGE</i>	203
SYSTEM EVENTS	204
<i>ALERT EVENTS LIST</i>	204
<i>ALERT LOG</i>	206
<i>ALERT CONTACT</i>	207
CDR.....	207
<i>DOWNLOADED CDR FILE</i>	209
<i>STATISTICS</i>	211
<i>RECORDING FILES</i>	212
<i>CDR API CONFIGURATION FILES</i>	213
UPGRADING AND MAINTENANCE	219
UPGRADING.....	219

UPGRADING VIA NETWORK.....	219
UPGRADING VIA LOCAL UPLOAD.....	220
NO LOCAL FIRMWARE SERVERS.....	222
BACKUP	222
LOCAL BACKUP	223
DATA SYNC.....	223
RESTORE CONFIGURATION FROM BACKUP FILE	224
CLEANER.....	225
RESET AND REBOOT	226
SYSLOG	227
TROUBLESHOOTING	228
ETHERNET CAPTURE	228
IP PING.....	228
TRACEROUTE.....	229
PRI/SS7/MFC/R2 SIGNALING TRACE.....	229
ANALOG RECORD TRACE.....	230
EXPERIENCING THE UCM6510 SERIES IP PBX	233

Table of Tables
UCM6510 IP PBX User Manual

Table 1: Technical Specifications.....	16
Table 2: UCM6510 Equipment Packaging	19
Table 3: LCD Menu Options	24
Table 4: UCM6510 LED INDICATORS	25
Table 5: UCM6510 Network Settings->Basic Settings.....	31
Table 6: UCM6510 Network Settings->802.1X	37
Table 7: UCM6510 Network Settings->Static Routes	38
Table 8: UCM6510 Network Settings->Port Forwarding.....	40
Table 9: UCM6510 Firewall->Static Defense->Current Service.....	42
Table 10: Typical Firewall Settings	43
Table 11: Firewall Rule Settings	43
Table 12: UCM6510 Firewall Dynamic Defense	44
Table 13: Fail2Ban Settings	46
Table 14: HTTP Server Settings.....	53
Table 15: Email Settings.....	53
Table 16: Auto Time Updating	56
Table 17: Auto Provision Settings	61
Table 18: SIP Extension Configuration Parameters.....	65
Table 19: IAX Extension Configuration Parameters.....	69
Table 20: FXS Extension Configuration Parameters	71
Table 21: Batch Add SIP Extension Parameters.....	75
Table 22: Batch Add IAX Extension Parameters.....	77
Table 23: Analog Trunk Configuration Parameters	85
Table 24: PSTN Detection for Analog Trunk	90
Table 25: Analog Hardware Configuration Parameters.....	92
Table 26: Digital Hardware Configuration Parameters: E1 - PRI_NET/PRI_CPE	94
Table 27: Digital Hardware Configuration Parameters: E1 - SS7	96
Table 28: Digital Hardware Configuration Parameters: E1 - MFC/R2.....	97
Table 29: Digital Hardware Configuration Parameters: T1/J1 - PRI_NET/PRI_CPE.....	99
Table 30: Digital Hardware Configuration Parameters: T1/J1 - SS7.....	100
Table 31: Digital Trunk Configuration Parameters	102
Table 32: Data Trunk Configuration Parameters.....	106
Table 33: SIP Trunk Configuration Parameters.....	107
Table 34: IAX Trunk Configuration Parameters.....	111
Table 35: Outbound Route Configuration Parameters.....	117
Table 36: Inbound Rule Configuration Parameters	120
Table 37: Conference Bridge Configuration Parameters	125
Table 38: Conference Caller IVR Menu	129

Table 39: IVR Configuration Parameters	131
Table 40: Voicemail Settings	139
Table 41: Voicemail IVR Menu	140
Table 42: Voicemail Email Settings	142
Table 43: Voicemail Group Settings	143
Table 44: Ring Group Parameters	145
Table 45: Paging/Intercom Group Configuration Parameters	147
Table 46: Call Queue Configuration Parameters	149
Table 47: FAX/T.38 Settings	159
Table 48: DISA Settings	163
Table 49: Event List Settings.....	166
Table 50: UCM6510 Feature Codes	173
Table 51: Internal Options/General	179
Table 52: Internal Options/Jitter Buffer.....	181
Table 53: Internal Options/RTP Settings	181
Table 54: Internal Options/STUN Monitor	182
Table 55: IAX Settings/General.....	183
Table 56: IAX Settings/Registration	183
Table 57: IAX Settings/Static Defense	184
Table 58: SIP Settings/General	187
Table 59: SIP Settings/Misc	188
Table 60: SIP Settings/Session Timer	188
Table 61: SIP Settings/TCP and TLS	189
Table 62: SIP Settings/NAT	190
Table 63: SIP Settings/ToS.....	191
Table 64: Trunk Status.....	193
Table 65: Extension Status.....	195
Table 66: Agent Status	196
Table 67: Interface Status Indicators	197
Table 68: Digital Channel Status Indicators	200
Table 69: Parking Lot Status	201
Table 70: System Status->General	202
Table 71: System Status->Network	202
Table 72: CDR Filter Criteria	208
Table 73: CDR Statistics Filter Criteria	212
Table 74: CDR API Configuration Files	213
Table 75: CDR API URI Parameters	214
Table 76: Network Upgrade Configuration	220
Table 77: Data Sync Configuration	224
Table 78: Cleaner Configuration	226

Table of Figures
UCM6510 IP PBX User Manual

Figure 1: UCM6510 Front View.....	19
Figure 2: UCM6510 Back View.....	19
Figure 3: UCM6510 T1/E1/J1 Crossover Cable Pin-out.....	20
Figure 4: UCM6510 web GUI Login Page.....	26
Figure 5: UCM6510 web GUI Language.....	28
Figure 6: UCM6510 web GUI: Apply Changes.....	29
Figure 7: UCM6510 Network Interface Method: Route.....	34
Figure 8: UCM6510 Network Interface Method: Switch.....	35
Figure 9: UCM6510 Network Interface Method: Dual.....	36
Figure 10: UCM6510 Using 802.1X as Client.....	36
Figure 11: UCM6510 Using 802.1X EAP-MD5.....	37
Figure 12: UCM6510 Static Route Sample.....	39
Figure 13: UCM6510 Static Route Configuration.....	39
Figure 14: UCM6510 Port Forwarding Configuration.....	41
Figure 15: GXP2160 Web Access Using UCM6510 Port Forwarding.....	41
Figure 16: Create New Firewall Rule.....	43
Figure 17: Configure Dynamic Defense.....	45
Figure 18: LDAP Server Configurations.....	48
Figure 19: Default LDAP Phonebook DN.....	48
Figure 20: Default LDAP Phonebook Attributes.....	49
Figure 21: Add LDAP Phonebook.....	49
Figure 22: Edit LDAP Phonebook.....	50
Figure 23: GXP2200 LDAP Phonebook Configuration.....	52
Figure 24: UCM6510 Email Settings.....	54
Figure 25: UCM6510 Email Settings: Send Test Email.....	55
Figure 26: Set Time Manually.....	57
Figure 27: UCM6510 Zero Config.....	60
Figure 28: Auto Provision Settings.....	61
Figure 29: Auto Discover.....	62
Figure 30: Discovered Devices.....	63
Figure 31: Assign Extension To Device.....	63
Figure 32: Create New Device.....	64
Figure 33: Export Extensions.....	81
Figure 34: Export Extensions.....	81
Figure 35: Email To User: Prompt Information.....	82
Figure 36: Email To User: Account Registration Information and QR Code.....	83
Figure 37: Email To User: LDAP Client Information and QR Code.....	83
Figure 38: UCM6510 FXO Tone Settings.....	88

Figure 39: UCM6510 PSTN Detection.....	88
Figure 40: UCM6510 PSTN Detection: Auto Detect	89
Figure 41: UCM6510 PSTN Detection: Semi-Auto Detect	89
Figure 42: FXS Ports Signaling Preference	91
Figure 43: FXO Ports ACIM Settings	91
Figure 44: Digital Hardware Configuration	93
Figure 45: Troubleshooting Digital Trunks	104
Figure 46: Data Trunk Web Page.....	105
Figure 47: Data Trunk Configuration	106
Figure 48: DOD extension selection	115
Figure 49: Edit DOD.....	115
Figure 50: Blacklist Configuration Parameters.....	122
Figure 51: Conference Invitation From web GUI	127
Figure 52: Conference Recording.....	130
Figure 53: Click On Prompt To Create IVR Prompt	133
Figure 54: Record New IVR Prompt	133
Figure 55: Upload IVR Prompt.....	134
Figure 56: Language Settings for Voice Prompt	136
Figure 57: Voice Prompt Package List.....	136
Figure 58: New Voice Prompt Language Added	137
Figure 59: Voicemail Email Settings	142
Figure 60: Voicemail Group.....	143
Figure 61: Ring Group.....	145
Figure 62: Ring Group Configuration	146
Figure 63: Paging/Intercom Group.....	147
Figure 64: Page/Intercom Group Settings	148
Figure 65: Call Queue	149
Figure 66: Agent Login Settings	151
Figure 67: Edit Extension Group.....	153
Figure 68: Select Extension Group in Outbound Route.....	154
Figure 69: Edit Pickup Group	155
Figure 70: Music On Hold Default Class.....	157
Figure 71: Configure Analog Trunk without Fax Detection	160
Figure 72: Configure Extension For Fax Machine	161
Figure 73: Configure Inbound Rule for Fax.....	161
Figure 74: Create Fax Extension	162
Figure 75: Inbound Route to Fax Extension	162
Figure 76: Create New DISA.....	163
Figure 77: Create New Event List	166
Figure 78: Create Dial By Name Group	169
Figure 79: Dial By Name Group In IVR Key Pressing Events	170

Figure 80: Dial By Name Group In Inbound Route	170
Figure 81: Configure Extension First Name And Last Name	171
Figure 82: Download Recording File from CDR Page	177
Figure 83: Status->PBX Status	193
Figure 84: Trunk Status	193
Figure 85: Extension Status	195
Figure 86: Queue Status	196
Figure 87: Conference Room Status.....	197
Figure 88: Digital Channels Status.....	200
Figure 89: Parking Lot Status.....	201
Figure 90: System Status->Storage Usage.....	203
Figure 91: System Status->Resource Usage.....	204
Figure 92: System Events->Alert Events Lists: Disk Usage	204
Figure 93: System Events->Alert Events Lists: Modify Admin Password	205
Figure 94: System Events->Alert Events Lists: Memory Usage	205
Figure 95: System Events->Alert Events Lists: System Reboot.....	205
Figure 96: System Events->Alert Events Lists: System Update.....	206
Figure 97: System Events->Alert Events Lists: System Crash	206
Figure 98: System Events->Alert Log	207
Figure 99: CDR Filter	208
Figure 100: Call Report	209
Figure 101: Call Report Entry with Audio Recording File.....	209
Figure 102: Downloaded CDR File Sample - Call To Shows "s"	210
Figure 103: Downloaded CDR File Sample - Source Channel and Dest Channel 1.....	210
Figure 104: Downloaded CDR File Sample - Source Channel and Dest Channel 2.....	211
Figure 105: Downloaded CDR File Sample - Source Channel and Dest Channel 3.....	211
Figure 106: CDR Statistics	212
Figure 107: Network Upgrade	219
Figure 108: Local Upgrade.....	220
Figure 109: Upgrading Firmware Files.....	221
Figure 110: Reboot UCM6510	221
Figure 111: Local Backup.....	223
Figure 112: Data Sync.....	224
Figure 113: Restore UCM6510 from Backup File	225
Figure 114: Cleaner.....	226
Figure 115: Reset and Reboot	227
Figure 116: Ethernet Capture.....	228
Figure 117: PING.....	229
Figure 118: Traceroute	229
Figure 119: Troubleshooting Analog Trunks.....	231

CHANGE LOG

This section documents significant changes from previous versions of the UCM6510 user manual. Only major new features or major document updates are listed here. Minor updates for corrections or editing are not documented here.

FIRMWARE VERSION 1.0.0.25

- This is the initial version.

WELCOME

Thank you for purchasing Grandstream UCM6510 IP PBX appliance. The UCM6510 is an innovative IP PBX appliance for E1/T1/J1 networks that brings enterprise-grade unified communications and security protection to enterprises, small-to-medium businesses (SMBs), retail environments and residential settings in an easy-to-manage fashion. Powered by an advanced hardware platform and revolutionary software functionalities, the UCM6510 offers a breakthrough turnkey solution for converged voice, video, data, fax, security surveillance, and mobility applications out of the box without any extra license fees or recurring costs.

 **Caution:**

Changes or modifications to this product not expressly approved by Grandstream, or operation of this product in any way other than as detailed by this User Manual, could void your manufacturer warranty.

 **Warning:**

Please do not use a different power adapter with the UCM6510 as it may cause damage to the products and void the manufacturer warranty.

This document is subject to change without notice. The latest electronic version of this user manual is available for download here:

<http://www.grandstream.com/support>

Reproduction or transmittal of the entire or any part, in any form or by any means, electronic or print, for any purpose without the express written permission of Grandstream Networks, Inc. is not permitted.

PRODUCT OVERVIEW

FEATURE HIGHLIGHTS

- 1 GHz quad-core Cortex A9 application processor, large memory (1GB DDR3 RAM, 32GB Flash), and dedicated high performance multi-core DSP array for advanced voice processing
- 1 Integrated 1 T1/E1/J1 interface, 2 PSTN trunk FXO ports, 2 analog telephone/Fax FXS ports with lifeline capability in case of power outage, and up to 50 SIP trunk accounts
- Hardware DSP based 128ms-tail-length carrier-grade line echo cancellation (LEC), hardware based caller ID/call progress tone and smart automated impedance matching for various countries
- Gigabit network port(s) with integrated PoE, USB, SD card; integrated NAT router with advanced QoS support
- Strong defense against malicious attacks (Fail2ban, Whitelist, Blacklist, alerts, etc.)
- Data communication via T1/E1/J1 and data-voice combined communication via T1/E1/J1 with SS7 or PRI
- Supports up to 2000 SIP endpoint registrations, up to 200 concurrent calls (up to 100 SRTP encrypted concurrent calls), and up to 64 conference attendees
- Flexible dial plan, call routing, site peering, call recording (manual and automatic per SIP call and SIP trunk), central control panel for endpoints, integrated NTP server, and integrated LDAP contact directory
- Automated detection and provisioning of IP phones, video phones, ATAs, gateways, SIP cameras, and other endpoints for easy deployment
- Strongest-possible security protection using SRTP, TLS, and HTTPS with hardware encryption accelerator
- Redundant power supply, advanced support for Hot Standby Clustering and High Availability to minimize system down time (pending)
- Automatic export of previous day's data; periodically cleans up user data

TECHNICAL SPECIFICATIONS

Table 1: Technical Specifications

Interfaces	
Analog Telephone FXS Ports	2 RJ11 ports (both with lifetime capability in case of power outage)
PSTN Line FXO Ports	2 RJ11 ports (both with lifetime capability in case of power outage)
T1/E1/J1 Interface	1 RJ45 port
Network Interfaces	Dual Gigabit ports (switched or routed) with PoE; A 3 rd Gigabit port for Hot-Standby Clustering
NAT Router	Yes (user configurable)
Peripheral Ports	USB, SD
LED Indicators	Power 1/2, PoE, USB, SD, T1/E1/J1, FXS 1/2, FXO 1/2, LAN, WAN, Cluster Heartbeat
LCD Display	128x32 dot matrix graphic LCD with DOWN and OK buttons
Reset Switch	Yes, long press for factory reset and short press for reboot
Voice/Video Capabilities	
Voice-over-Packet Capabilities	LEC with NLP Packetized Voice Protocol Unit, 128ms-tail-length carrier grade Line Echo Cancellation, Dynamic Jitter Buffer, Modem detection and auto-switch to G.711
Voice and Fax Codecs	G.711 A-law/U-law, G.722, G.723.1 5.3K/6.3K, G.726, G.729A/B, iLBC, GSM, AAL2-G.726-32, ADPCM; T.38
Video Codecs	H.264, H.263, H.263+
QoS	Layer 3 QoS, Layer 2 QoS
Signaling and Control	
DTMF Methods	In Audio, RFC2833, and SIP INFO
Digital Signaling	PRI, SS7, MFC/R2
Provisioning Protocol and Plug-and-Play	TFTP/HTTP/HTTPS, auto-discovery & auto-provisioning of Grandstream IP endpoints via ZeroConfig (DHCP Option 66/multicast SIP SUBSCRIBE/mDNS), eventlist between local and remote trunks
Network Protocols	TCP/UDP/IP, RTP/RTCP, ICMP, ARP, DNS, DDNS, DHCP, NTP, TFTP, SSH, HTTP/HTTPS, PPPoE, SIP (RFC3261), STUN, SRTP, TLS, LDAP, HDLC, HDLC-ETH, PPP, Frame Relay (pending)
Disconnect Methods	Call Progress Tone, Polarity Reversal, Hook Flash Timing, Loop Current Disconnect, Busy Tone
Security	

Media	SRTP, TLS, HTTPS, SSH
Advanced Defense	Fail2ban, alert events, Whitelist, Blacklist, strong password based access control
Physical	
Universal Power Supply	Input: 100-240VAC, 50-60Hz; Output: DC+12VDC, 1.5A
Physical	Unit Weight: 2.165 KG; Package weight: 3.012 KG
Dimensions	440mm (L) x 185mm (W) x 44mm (H)
Environmental	Operating: 32 - 113°F / 0 - 45°C, Humidity 10-90% (non-condensing) Storage: 14 - 140°F / -10 - 60°C, Humidity 10-90% (non-condensing)
Mounting	Rack mount and Desktop
Additional Features	
Multi-language Support	English, Simplified Chinese, Traditional Chinese, Spanish, French, Portuguese, German, Russian, Italian, Polish, Czech for web GUI; Customizable IVR/voice prompts for English, Chinese, British English, German, Spanish, Greek, French, Italian, Dutch, Polish, Portuguese, Russian, Swedish, Turkish, Hebrew and Arabic
Caller ID	Bellcore/Telcordia, ETSI-FSK, ETSI-DTMF, SIN 227 - BT, NTT Japan (pending)
Polarity Reversal/ Wink	Yes, with enable/disable option upon call establishment and termination
Call Center	Multiple configurable call queues, automatic call distribution (ACD) based on agent skills/availability/busy level, in-queue announcement
Customizable Auto Attendant	Up to 5 layers of IVR (Interactive Voice Response)
Maximum Call Capacity	Up to 2000 registered SIP endpoints, up to 200 concurrent calls
Conference Bridges	Up to 8 bridges, up to 64 simultaneous conference attendees
Call Features	Call park, call forward, call transfer, DND, DISA, ring group, pickup group, blacklist, paging/intercom and etc
Compliance	<ul style="list-style-type: none"> FCC: Part 15 (CFR 47) Class B, Part 68 CE: EN55022 Class B, EN55024, EN61000-3-2, EN61000-3-3, EN60950-1, TBR21, RoHS A-TICK: AS/NZS CISPR 22 Class B, AS/NZS CISPR 24, AS/NZS 60950, AS/ACIF S002 ITU-T K.21 (Basic Level); UL 60950 (power adapter) T1: TIA-968-B Section 5.2.4 E1: TBR12/TBR13, E1: AS/ACIF

This page intentionally left blank

INSTALLATION

Before deploying and configuring the UCM6510 series, the device needs to be properly powered up and connected to network. This section describes detailed information on installation, connection and warranty policy of the UCM6510 series.

EQUIPMENT PACKAGING

Table 2: UCM6510 Equipment Packaging

Main Case	Yes (x 1)
Power Adapter	Yes (x 2)
Ethernet Cable	Yes (x 1)
Wall Mount	Yes (x 2)
Screws	Yes (x 6)
Quick Installation Guide	Yes (x 1)

CONNECT YOUR UCM6510

CONNECT THE UCM6510

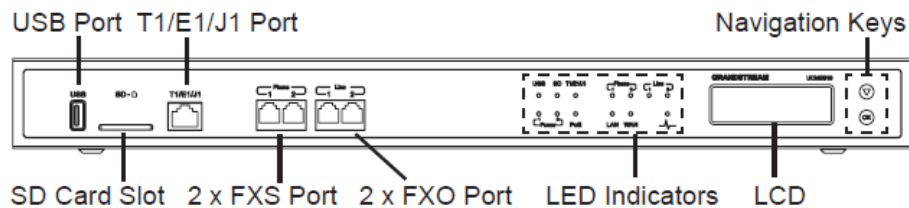

Figure 1: UCM6510 Front View

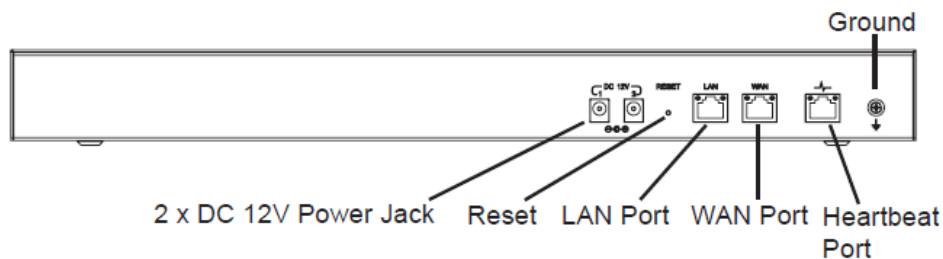

Figure 2: UCM6510 Back View

Follow the steps below to connect the UCM6510 for initial setup:

1. Connect one end of an RJ-45 Ethernet cable (cable type: straight through) into the WAN port of the UCM6510; connect the other end into the uplink port of an Ethernet switch/hub.
2. Connect the 12V DC power adapter into the DC 12V power jack 1 on the back of the UCM6510. Insert the main plug of the power adapter into a surge-protected power outlet. (Connect the second power adapter into the DC 12V power jack 2 for failover purpose in case the first one is down).
3. Wait for the UCM6510 to boot up. The LCD in the front will show its hardware information when the bootup process is done.
4. Once the UCM6510 is successfully connected to the network, the LED indicator for the WAN port in the front will be in solid green and the LCD shows up the IP address.

Depending on how the UCM6510 is used, users can follow the steps below for optional setup:

1. PSTN Line Connection: connect PSTN lines from the wall jack to the UCM6510 LINE ports (FXO ports).
2. Analog Line Connection: connect analog lines (phone and fax) to the PHONE ports (FXS ports).
3. T1/E1/J1 Line Connection: connect one end of the T1/E1/J1 cable provided from the service provider into the T1/E1/J1 port of the UCM6510; connect the other end into the T1/E1/J1 wall jack. T1/E1/J1 crossover cable should be used and it's not provided in the UCM6510 package. Please see T1/E1/J1 crossover cable pin-out in the figure below:

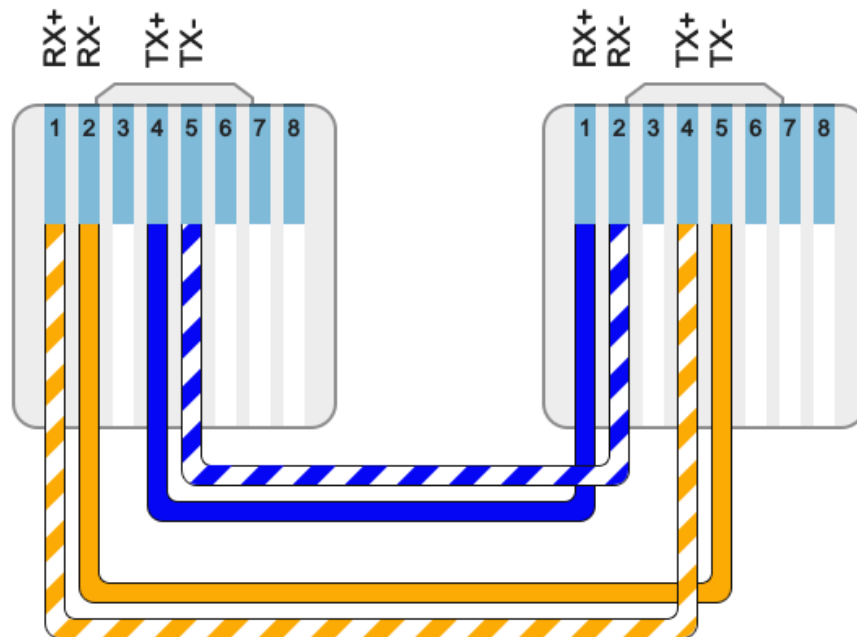

Figure 3: UCM6510 T1/E1/J1 Crossover Cable Pin-out

SAFETY COMPLIANCES

The UCM6510 series IP PBX complies with FCC/CE and various safety standards. The UCM6510 power adapter is compliant with the UL standard. Use the universal power adapter provided with the UCM6510 package only. The manufacturer's warranty does not cover damages to the device caused by unsupported power adapters.

WARRANTY

If the UCM6510 series IP PBX was purchased from a reseller, please contact the company where the device was purchased for replacement, repair or refund. If the device was purchased directly from Grandstream Networks, contact our Technical Support Team for a RMA (Return Materials Authorization) number before the product is returned. Grandstream Networks reserves the right to remedy warranty policy without prior notification.

 **Warning:**

Use the power adapter provided with the UCM6510 series IP PBX. Do not use a different power adapter as this may damage the device. This type of damage is not covered under warranty.

This page intentionally left blank

GETTING STARTED

The UCM6510 provides LCD interface, LED indication and web GUI configuration interface.

- The LCD displays hardware, software and network information. Users could also navigate in the LCD menu for device information and basic network configuration.
- The LED indication at the front of the device provides interface connection and activity status.
- The web GUI gives users access to all the configurations and options for UCM6510 setup.

This section provides step-by-step instructions on how to use the LCD menu, LED indicators and web GUI of the UCM6510. Once the basic settings are done, users could start making calls from UCM6510 extension registered on a SIP phone as described at the end of this section.

USE THE LCD MENU

- **Default LCD Display**

By default, when the device is powered up, the LCD will show device model (e.g., UCM6510), hardware version (e.g., V1.4A) and IP address. Press "Down" button and the system time will be displayed (e.g., 2014-10-21 14:20).

- **Menu Access**

Press "OK" button to start browsing menu options. Please see menu options in [Table 3: LCD Menu Options].

- **Menu Navigation**

Press the "Down" arrow key to browser different menu options. Press the "OK" button to select an entry.

- **Exit**

If "Back" option is available in the menu, select it to go back to the previous menu. For "Device Info" "Network Info" and "Web Info" which do not have "Back" option, simply press the "OK" button to go back to the previous menu. Additionally, the LCD will display default idle screen after staying in menu option for 15 seconds.

- **LCD Backlight**

The LCD backlight will be on upon key pressing. The backlight will go off after the LCD stays in idle for 30 seconds.

The following table shows the LCD menu options.

Table 3: LCD Menu Options







View Events	<ul style="list-style-type: none"> • Critical Events • Other Events
Device Info	<ul style="list-style-type: none"> • Hardware: Hardware version number • Software: Software version number • P/N: Part number • WAN MAC: WAN side MAC address • LAN MAC: LAN side MAC address • Uptime: System up time since the last reboot
Network Info	<ul style="list-style-type: none"> • WAN Mode: DHCP, Static IP, or PPPoE • WAN IP: IP address • WAN Subnet Mask • LAN IP: IP address • LAN Subnet Mask
Network Menu	<ul style="list-style-type: none"> • WAN Mode: Select WAN mode as DHCP, Static IP or PPPoE • Static Routes Reset: Click to reset the static route setting
Factory Menu	<ul style="list-style-type: none"> • Reboot • Factory Reset • LCD Test Patterns Press "OK" to start. Then press "Down" button to test different LCD patterns. When done, press "OK" button to exit. • Fan Mode Select "Auto" or "On". • LED Test Patterns Select "All On" "All Off" or "Blinking" and check LED status for USB, SD, T1/E1/J1, Phone 1/Phone 2, Line 1/Line 2 ports. After the LED test, select "Back" in the menu and the device will show the LED actual status again. • RTC Test Patterns Select "2022-02-22 22:22" or "2011-01-11 11:11" to start the RTC (Real-Time Clock) test pattern. Check the system time from LCD idle screen by pressing "DOWN" button, or from web GUI->System Status->General page. After the test, reboot the device manually and the device will display

	<p>the correct time.</p> <ul style="list-style-type: none"> • Hardware Testing Select "Test SVIP" to perform SVIP test on the device. This is mainly for factory testing purpose which verifies the hardware connection inside the device. The diagnostic result displays on the LCD after the test is done.
Web Info	<ul style="list-style-type: none"> • Protocol: Web access protocol. HTTP or HTTPS. By default it's HTTPS • Port: Web access port number. By default it's 8089

USE THE LED INDICATORS

The UCM6510 has LED indicators in the front to display connection status. The following table shows the status definitions.

Table 4: UCM6510 LED INDICATORS

LED Indicator	LED Status
Power 1/Power 2 PoE LAN WAN USB SD Phone 1 /Phone 2 (FXS) Line 1/Line 2 FXO	<p> Solid: Connected</p> <p> Fast Blinking: Data Transferring</p> <p> Slow Blinking: Trying to connect</p> <p> OFF: Not Connected</p>
T1/E1/J1	<p> Solid: Connected and working</p> <p> Fast Blinking (0.5s on/0.5s off): No cable is connected; or connected but the link is not working at all.</p> <p> Slow Blinking (1s on/1s off): Connected but the link is only working one-way</p>

USE THE WEB GUI

ACCESS WEB GUI

The UCM6510 embedded Web server responds to HTTP/HTTPS GET/POST requests. Embedded HTML pages allow users to configure the device through a Web browser such as Microsoft IE (version 8+), Mozilla Firefox, Google Chrome and etc.



Figure 4: UCM6510 web GUI Login Page

To access the web GUI:

1. Connect the computer to the same network as the UCM6510.
2. Ensure the device is properly powered up and shows its IP address on the LCD.
3. Open a web browser on the computer and enter the IP address in the address bar. The web login page will display as shown in **[Figure 4: UCM6510 web GUI Login Page]**.
4. Enter the administrator's login and password to access the web configuration menu. The default administrator's username and password is "admin" and "admin". It is highly recommended to change the default password after login for the first time.

 **Note:**

By default, the UCM6510 has "Redirect From Port 80" enabled. Therefore, if users type in the UCM6510 IP address in the web browser, the web page will be automatically redirected to the page using HTTPS and port 8089.

For example, if the LCD shows 192.168.40.167, please enter 192.168.40.167 in your web browser and the web page will be redirected to:

https://192.168.40.167:8089

The option "Redirect From Port 80" can be configured under the UCM6510 web GUI->**Settings->HTTP Server**.

WEB GUI CONFIGURATIONS

There are four main sections in the web GUI for users to view the PBX status, configure and manage the PBX.

- **Status:** Displays PBX status, System Status, System Events and CDR.
- **PBX:** To configure extensions, trunks, call routes, zero config for auto provisioning, call features, internal options, IAX settings, SIP settings, as well as ports configuration for digital trunks.
- **Settings:** To configure network settings, firewall settings, change password, LDAP Server, HTTP Server, Email Settings, Time Settings and NTP server.
- **Maintenance:** To perform firmware upgrade, backup configurations, cleaner setup, reset/reboot, syslog setup and troubleshooting.

WEB GUI LANGUAGES

Currently the UCM6510 web GUI supports the following languages:

English

Simplified Chinese

Traditional Chinese

- Spanish**
- French**
- Portuguese**
- Russian**
- Italian**
- Polish**
- German**
- Czech**

Users can select the displayed language in web GUI login page, or at the upper right of the web GUI after logging in.

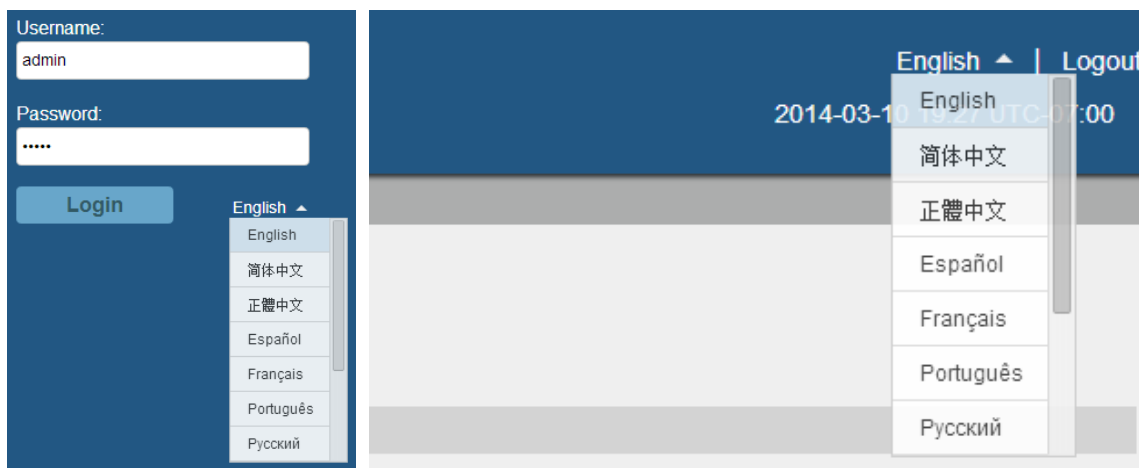

Figure 5: UCM6510 web GUI Language

SAVE AND APPLY CHANGES

Click on "Save" button after configuring the web GUI options in one page. After saving all the changes, make sure click on "Apply Changes" button on the upper right of the web page to submit all the changes. If the change requires reboot to take effect, a prompted message will pop up for you to reboot the device.

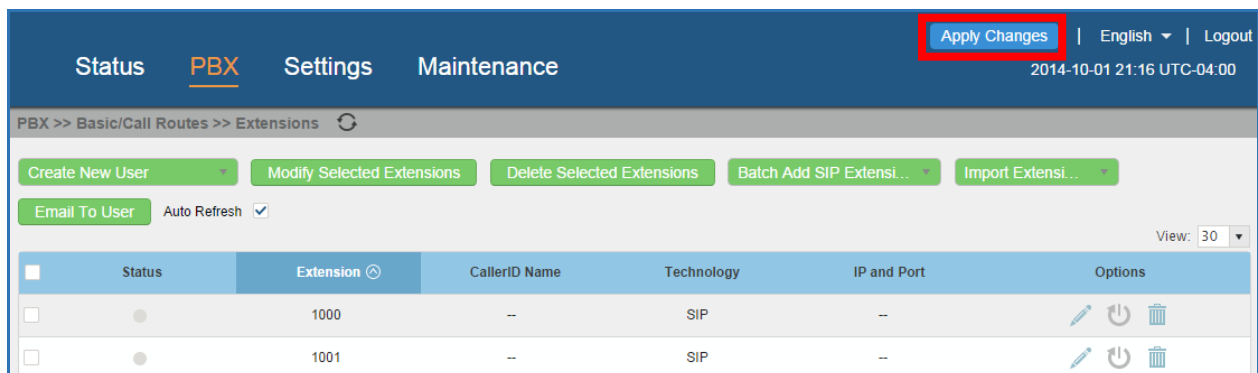

Figure 6: UCM6510 web GUI: Apply Changes

MAKE YOUR FIRST CALL

Power up the UCM6510 and your SIP end point phone. Connect both devices to the network. Then follow the steps below to make your first call.

1. Log in the UCM6510 web GUI, go to **PBX->Basic/Call Routes->Extensions**.
2. Click on "Create New SIP Extension" to create a new extension. You will need User ID, Password and Voicemail Password information to register and use the extension later.
3. Register the extension on your phone with the SIP User ID, SIP server and SIP Password information. The SIP server address is the UCM6510 IP address.
4. When your phone is registered with the extension, dial *97 to access the voicemail box. Enter the Voicemail Password once you hear "Password" voice prompt.
5. Once successfully logged in to the voicemail, you will be prompted with the Voice Mail Main menu.
6. You are successfully connected to the PBX system now.

This page intentionally left blank

SYSTEM SETTINGS

This section explains configurations for system-wide parameters on the UCM6510. Those parameters include Network Settings, Firewall, Change Password, LDAP server, HTTP server, Email settings, Time Settings and NTP Server settings.

NETWORK SETTINGS

After successfully connecting the UCM6510 to the network for the first time, users could log in the web GUI and go to **Settings->Network Settings** to configure the network parameters for the device. Select each tab in web GUI->**Settings->Network Settings** page to configure LAN/WAN settings, 802.1X and Port Forwarding.

 **Note:**

To connect the UCM6510 to network, T1/E1/J1 data trunk can also be used, instead of using the WAN/LAN port. Please see section **[DATA TRUNK]** to use UCM6510 data trunk to connect the device to Internet.

BASIC SETTINGS

Please refer to the following tables for basic network configuration parameters on the UCM6510.

Table 5: UCM6510 Network Settings->Basic Settings

Method	<p>Select "Route", "Switch" or "Dual" mode on the network interface of UCM6510. The default setting is "Route".</p> <ul style="list-style-type: none"> • Route WAN port interface will be used for uplink connection. LAN port interface will be used to serve as router. • Switch WAN port interface will be used for uplink connection. LAN port interface will
--------	---

	<p>be used as bridge for PC connection.</p> <ul style="list-style-type: none"> • Dual Both ports can be used for uplink connection. Users will need assign LAN 1 or LAN 2 as the default interface in option "Default Interface" and configure "Gateway IP" for this interface if static IP is used for the interface.
Preferred DNS Server	Enter the preferred DNS server address.
WAN (when "Method" is set to "Route")	
IP Method	Select DHCP, Static IP, or PPPoE. The default setting is DHCP.
IP Address	Enter the IP address for static IP settings. The default setting is 192.168.0.160.
Subnet Mask	Enter the subnet mask address for static IP settings. The default setting is 255.255.0.0.
Gateway IP	Enter the gateway IP address for static IP settings. The default setting is 0.0.0.0.
DNS Server 1	Enter the DNS server 1 address for static IP settings. The default setting is 0.0.0.0.
DNS Server 2	Enter the DNS server 2 address for static IP settings.
User Name	Enter the user name to connect via PPPoE.
Password	Enter the password to connect via PPPoE.
Layer 2 QoS 802.1Q/VLAN Tag	Assign the VLAN tag of the layer 2 QoS packets for WAN port. The default value is 0.
Layer 2 QoS 802.1p Priority Value	Assign the priority value of the layer 2 QoS packets for WAN port. The default value is 0.
LAN (when Method is set to "Route")	
IP Address	Enter the IP address assigned to LAN port. The default setting is 192.168.2.1.
Subnet Mask	Enter the subnet mask. The default setting is 255.255.255.0.
DHCP Server Enable	Enable or disable DHCP server capability. The default setting is "Yes".
DNS Server 1	Enter DNS server address 1. The default setting is 8.8.8.8.
DNS Server 2	Enter DNS server address 2. The default setting is 208.67.222.222.
Allow IP Address From	Enter the DHCP IP Pool starting address. The default setting is 192.168.2.100.
Allow IP Address To	Enter the DHCP IP Pool ending address. The default setting is 192.168.2.254.
Default IP Lease Time	Enter the IP lease time (in seconds). The default setting is 43200.
LAN (when Method is set to "Switch")	
IP Method	Select DHCP, Static IP, or PPPoE. The default setting is DHCP.
IP Address	Enter the IP address for static IP settings. The default setting is 192.168.0.160.
Subnet Mask	Enter the subnet mask address for static IP settings. The default setting is 255.255.0.0.
Gateway IP	Enter the gateway IP address for static IP settings. The default setting is 0.0.0.0.

DNS Server 1	Enter the DNS server 1 address for static IP settings. The default setting is 0.0.0.0.
DNS Server 2	Enter the DNS server 2 address for static IP settings.
User Name	Enter the user name to connect via PPPoE.
Password	Enter the password to connect via PPPoE.
Layer 2 QoS 802.1Q/VLAN Tag	Assign the VLAN tag of the layer 2 QoS packets for LAN port. The default value is 0.
Layer 2 QoS 802.1p Priority Value	Assign the priority value of the layer 2 QoS packets for LAN port. The default value is 0.
LAN 1 / LAN 2 (when Method is set to "Dual")	
Default Interface	If "Dual" is selected as "Method", users will need assign the default interface to be LAN 1 (mapped to UCM6510 WAN port) or LAN 2 (mapped to UCM6510 LAN port) and then configure network settings for LAN 1 and LAN 2. The default interface is LAN 2.
IP Method	Select DHCP, Static IP, or PPPoE. The default setting is DHCP.
IP Address	Enter the IP address for static IP settings. The default setting is 192.168.0.160.
Subnet Mask	Enter the subnet mask address for static IP settings. The default setting is 255.255.0.0.
Gateway IP	Enter the gateway IP address for static IP settings when the port is assigned as default interface. The default setting is 0.0.0.0.
DNS Server 1	Enter the DNS server 1 address for static IP settings. The default setting is 0.0.0.0.
DNS Server 2	Enter the DNS server 2 address for static IP settings.
User Name	Enter the user name to connect via PPPoE.
Password	Enter the password to connect via PPPoE.
Layer 2 QoS 802.1Q/VLAN Tag	Assign the VLAN tag of the layer 2 QoS packets for LAN port. The default value is 0.
Layer 2 QoS 802.1p Priority Value	Assign the priority value of the layer 2 QoS packets for LAN port. The default value is 0.

- **Method: Route**

WAN port interface is used for uplink connection; LAN port interface is used as a router. Please see a sample diagram below.

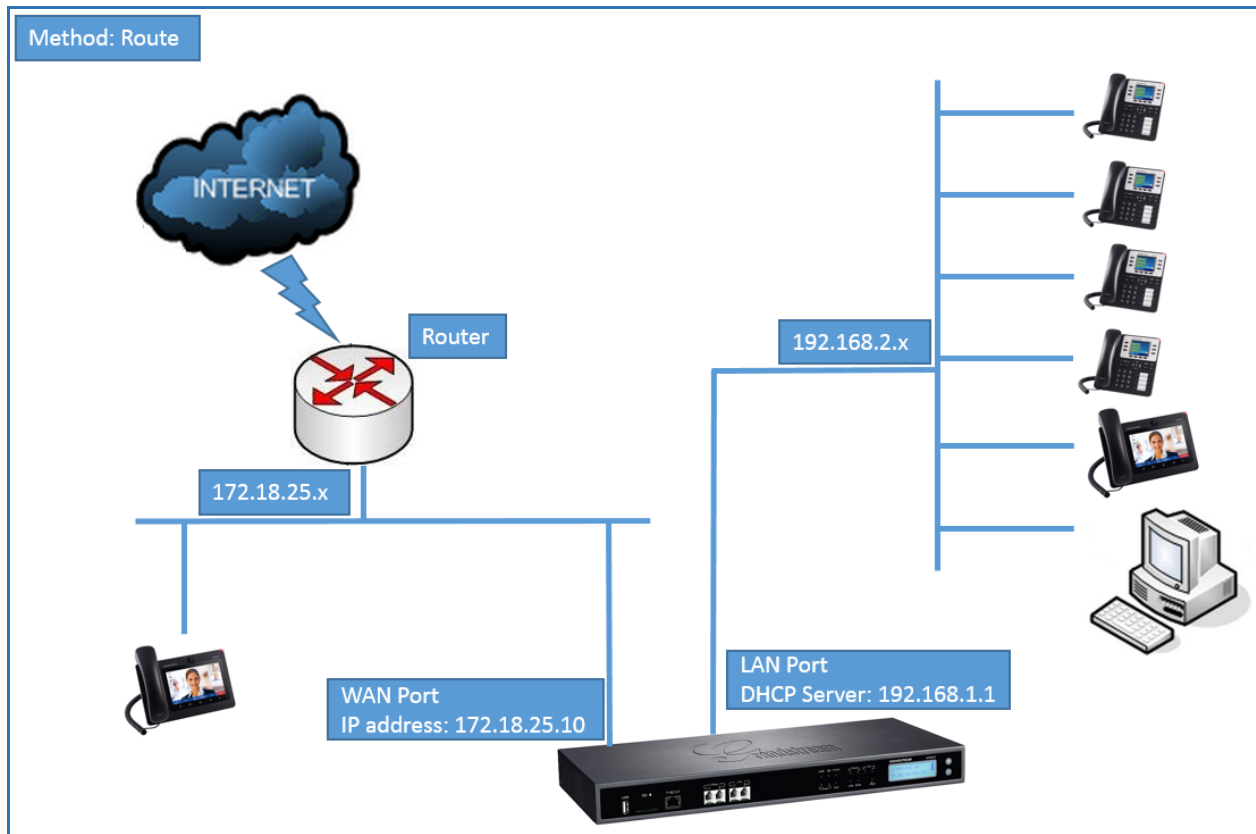

Figure 7: UCM6510 Network Interface Method: Route

- **Method: Switch**

WAN port interface is used for uplink connection; LAN port interface is used as bridge for PC connection.

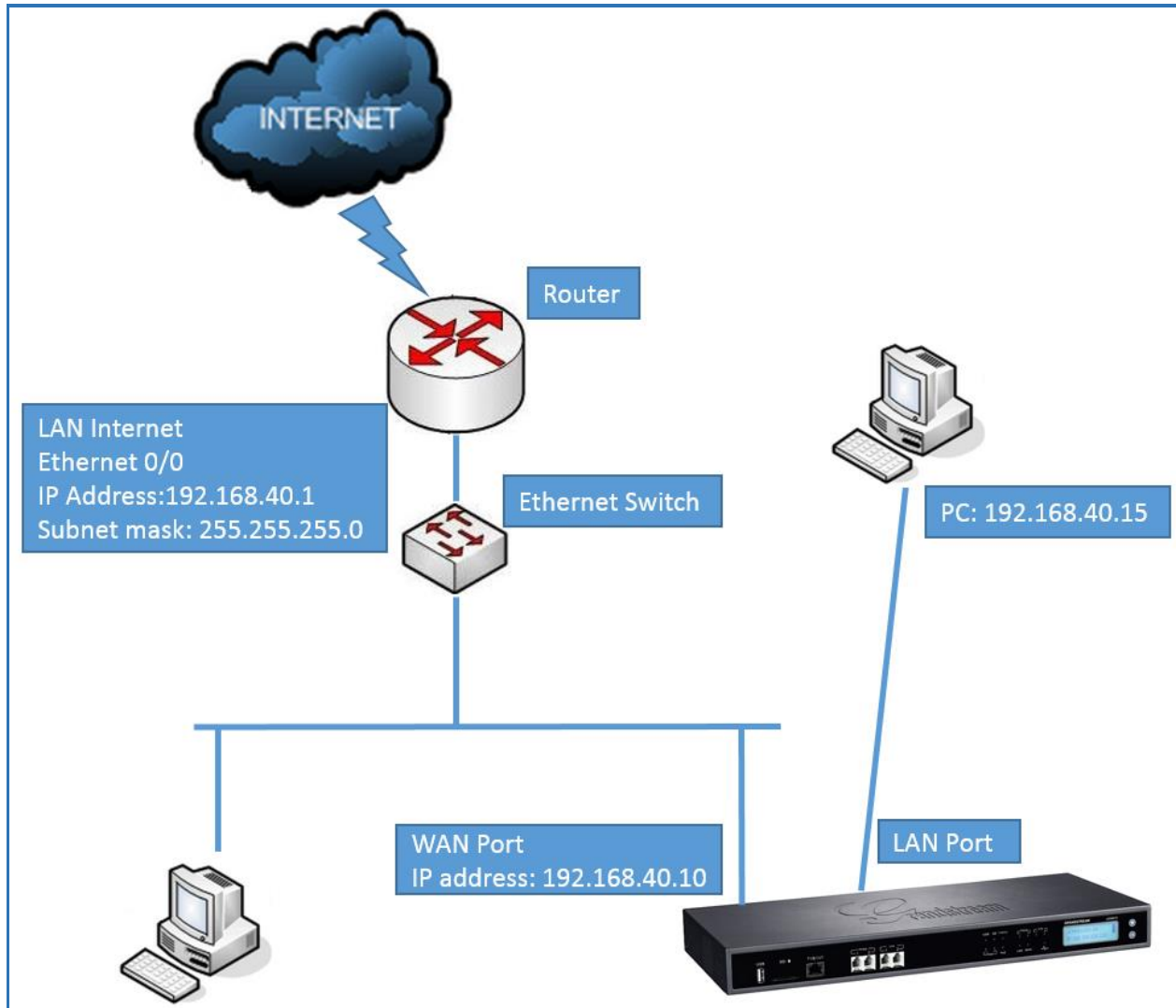

Figure 8: UCM6510 Network Interface Method: Switch

- **Method: Dual**

Both WAN port and LAN port are used for uplink connection. WAN port will be mapped to LAN 1 interface; LAN port will be mapped to LAN 2 interface. Users will need assign LAN 1 or LAN 2 as the default interface in option "Default Interface" and configure "Gateway IP" if static IP is used for this interface.

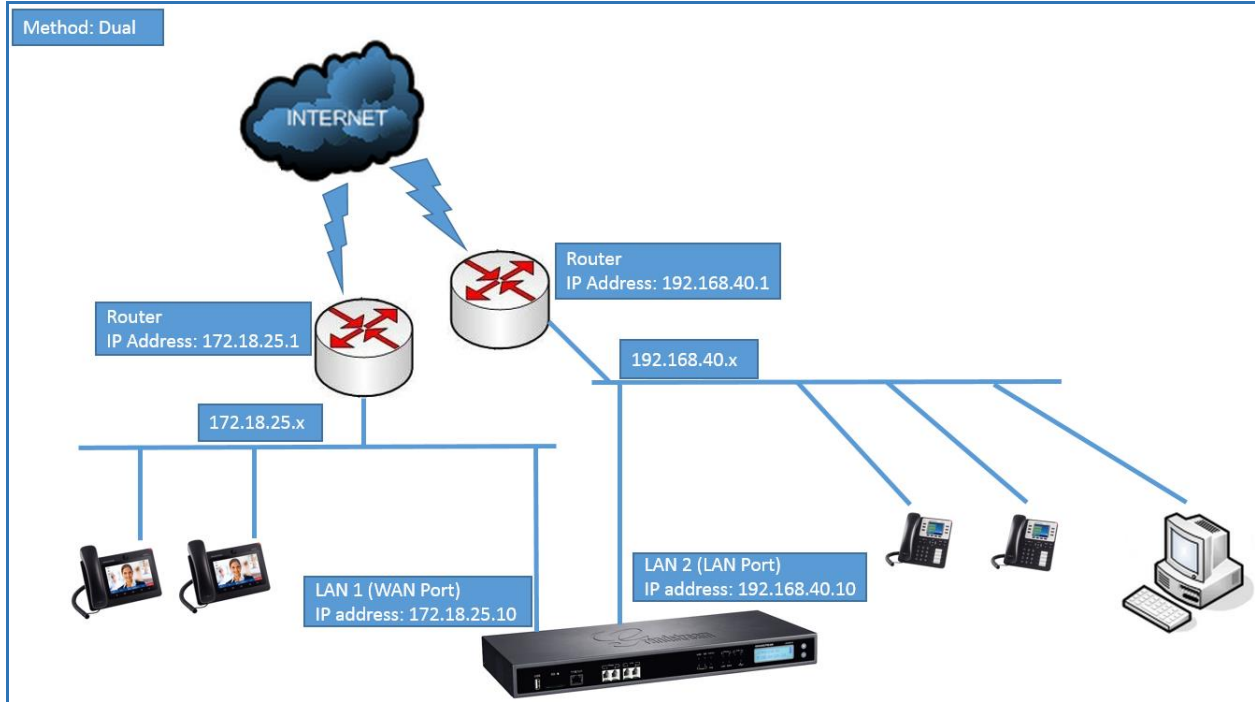

Figure 9: UCM6510 Network Interface Method: Dual

802.1X

IEEE 802.1X is an IEEE standard for port-based network access control. It provides an authentication mechanism to device before the device is allowed to access Internet or other LAN resources. The UCM6510 supports 802.1X as a supplicant/client to be authenticated. The following diagram and figure show UCM6510 uses 802.1X mode “EAP-MD5” on WAN port as client in the network to access Internet.

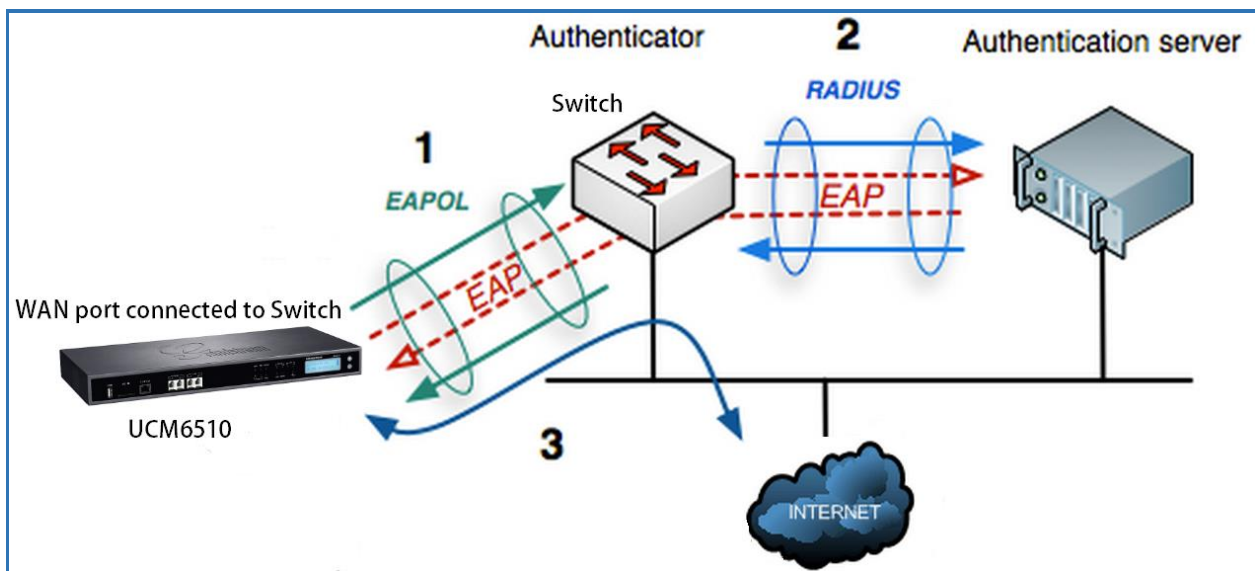

Figure 10: UCM6510 Using 802.1X as Client

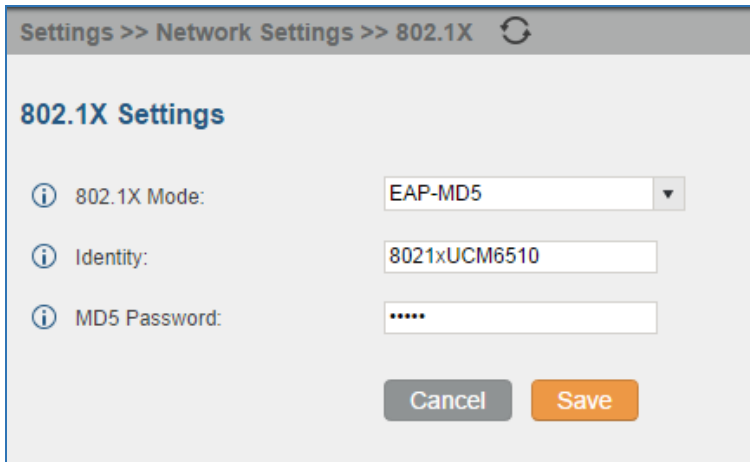

Figure 11: UCM6510 Using 802.1X EAP-MD5

The following table shows the configuration parameters for 802.1X on UCM6510. Identity and MD5 password are required for authentication, which should be provided by the network administrator obtained from the RADIUS server. If “EAP-TLS” or “EAP-PEAPv0/MSCHAPv2” is used as the 802.1X mode, users will also need upload 802.1X CA Certificate and 802.1X Client Certificate, which should be also generated from the RADIUS server.

Table 6: UCM6510 Network Settings->802.1X

802.1X Mode	Select 802.1X mode. The default setting is "Disable". The supported 802.1X mode are: <ul style="list-style-type: none"> • EAP-MD5 • EAP-TLS • EAP-PEAPv0/MSCHAPv2
Identity	Enter 802.1X mode identity information.
MD5 Password	Enter 802.1X mode MD5 password information.
802.1X CA Certificate	Select 802.1X certificate from local PC and then upload.
802.1X Client Certificate	Select 802.1X client certificate from local PC and then upload.

STATIC ROUTES

A static route is a pre-determined path that the network traffic travels to reach a specific host or network. On the UCM6510, the static route function allows the device to use manually configured routes, rather than dynamically assigned routes or default gateway configured in the UCM6510 web GUI->**Network Settings->Basic Settings** to forward traffic. It can be used to define a route when no other routes are available or necessary, or used in complementary with existing routing on the UCM6510 as a failover backup, and etc.



- Click on  to create a new static route. The configuration parameters are listed in the table below.
- Once added, users can select  to edit the static route.
- Select  to delete the static route.
- Static routes configuration can be reset from LCD menu->Network Menu.

Table 7: UCM6510 Network Settings->Static Routes

Destination	<p>Configure the destination IP address or the destination IP subnet for the UCM6510 to reach using the static route.</p> <p>Example: IP address - 192.168.66.4 IP subnet - 192.168.66.0</p>
Netmask	<p>Configure the subnet mask for the above destination address. If left blank, the default value is 255.255.255.255.</p> <p>Example: 255.255.255.0</p>
Gateway	<p>Configure the gateway address so that the UCM6510 can reach the destination via this gateway. Gateway address is optional.</p> <p>Example: 192.168.40.5</p>
Interface	<p>Specify the network interface "LAN" or "WAN" on the UCM6150 to reach the destination using the static route.</p>

The following diagram shows a sample application of static route usage on UCM6510.

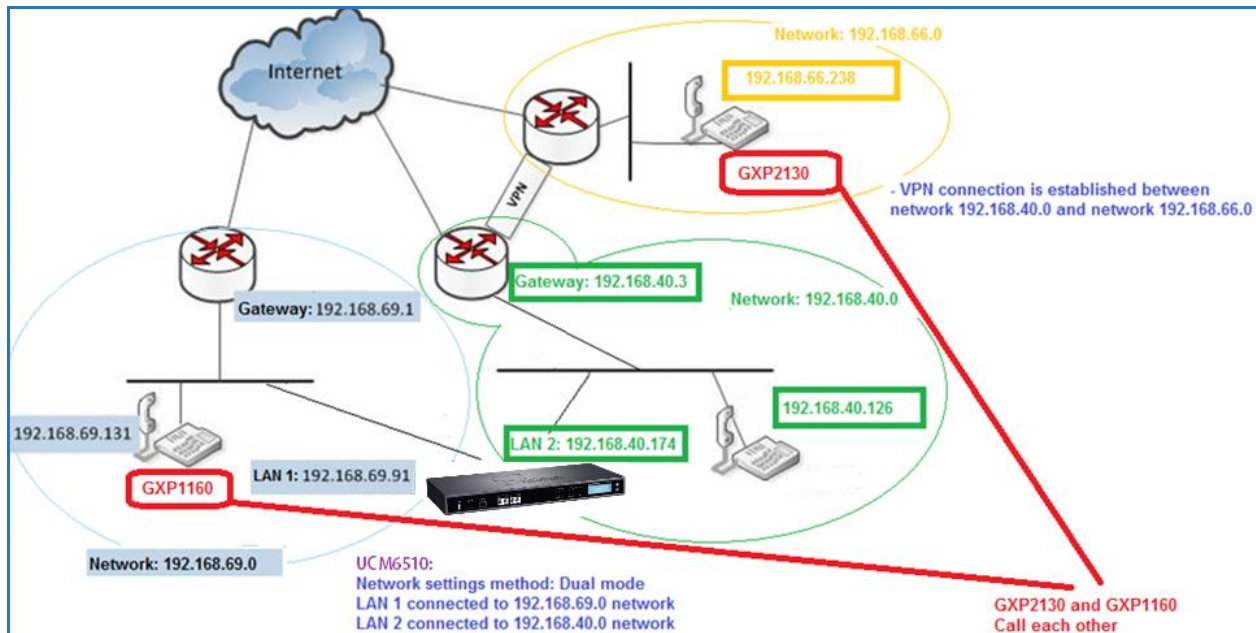

Figure 12: UCM6510 Static Route Sample

The network topology of the above diagram is as below:

- Network 192.168.69.0 has IP phones registered to UCM6510 LAN 1 address
- Network 192.168.40.0 has IP phones registered to UCM6510 LAN 2 address
- Network 192.168.66.0 has IP phones registered to UCM6510 via VPN
- Network 192.168.40.0 has VPN connection established with network 192.168.66.0

In this network, by default the IP phones in network 192.168.69.0 are unable to call IP phones in network 192.168.66.0 when registered on different interfaces on the UCM6510. Therefore, we need configure a static route on the UCM6510 so that the phones in isolated networks can make calls between each other.

Create New Static Route

i Destination:

i Netmask:

i Gateway:

i Interface:

Figure 13: UCM6510 Static Route Configuration

PORT FORWARDING

The UCM6510 network interface supports router functions which provides users the ability to do port forwarding. If the UCM6510 is set to "Route" under web GUI->**Settings->Network Settings->Basic Settings: Method**, port forwarding is available for configuration.

The port forwarding configuration is under web GUI->**Settings->Network Settings->Port Forwarding** page. Please see related settings in the table below.

Table 8: UCM6510 Network Settings->Port Forwarding

WAN Port	Specify the WAN port number. Up to 8 ports can be configured.
LAN IP	Specify the LAN IP address.
LAN Port	Specify the LAN port number.
Protocol Type	Select protocol type "UDP Only", "TCP Only" or "TCP/UDP" for the forwarding in the selected port. The default setting is "UDP Only".

The following figures demonstrate a port forwarding example to provide phone's web UI access to public side.

- The UCM6510 network mode is set to "Route"
- The UCM6510 WAN port is connected to uplink switch, with a public IP address configured, e.g. 1.1.1.1.
- The UCM6510 LAN port provides DHCP pool that connects to multiple phone devices in the LAN network 192.168.2.x. The UCM6510 is used as a router, with gateway address 192.168.2.1
- There is a GXP2160 connected under the LAN interface network of the UCM6510. It obtains IP address 192.168.2.100 from UCM6510 DHCP pool
- On the UCM6510 web UI->**Settings->Network Settings->Port Forwarding**, configure a port forwarding entry as the figure shows below.

WAN Port: This is the port opened up on the WAN side for access purpose.

LAN IP: This is the GXP2160 IP address, under the LAN interface network of the UCM6510.

Protocol Type: We select TCP here for web UI access using HTTP.

Settings >> Network Settings >> Port Forwarding 

Port Forwarding

Please configure the LAN mode as Router to enable this function.

Port Forwarding:	WAN Port:	<input type="text" value="8088"/>	LAN IP:	<input type="text" value="192.168.2.100"/>	LAN Port:	<input type="text" value="80"/>	Protocol Type:	TCP Only ▼
	WAN Port:	<input type="text"/>	LAN IP:	<input type="text"/>	LAN Port:	<input type="text"/>	Protocol Type:	UDP Only ▼
	WAN Port:	<input type="text"/>	LAN IP:	<input type="text"/>	LAN Port:	<input type="text"/>	Protocol Type:	UDP Only ▼
	WAN Port:	<input type="text"/>	LAN IP:	<input type="text"/>	LAN Port:	<input type="text"/>	Protocol Type:	UDP Only ▼
	WAN Port:	<input type="text"/>	LAN IP:	<input type="text"/>	LAN Port:	<input type="text"/>	Protocol Type:	UDP Only ▼
	WAN Port:	<input type="text"/>	LAN IP:	<input type="text"/>	LAN Port:	<input type="text"/>	Protocol Type:	UDP Only ▼
	WAN Port:	<input type="text"/>	LAN IP:	<input type="text"/>	LAN Port:	<input type="text"/>	Protocol Type:	UDP Only ▼
	WAN Port:	<input type="text"/>	LAN IP:	<input type="text"/>	LAN Port:	<input type="text"/>	Protocol Type:	UDP Only ▼

Figure 14: UCM6510 Port Forwarding Configuration

This will allow users to access the GXP2160 web UI from public side, by typing in address “1.1.1.1:8088”.

1.1.1.1:8088/#page=status_network

Grandstream GXP2160 Admin Logout Reboot English ▼

 Status Accounts Settings Network Maintenance Phonebook Version 1.0.4.16

Status

- Account Status
- Network Status**
- System Info

Network Status

MAC Address	00:08:82:59:A9:8D
IP Setting	DHCP
IPv4 Address	192.168.2.100
IPv6 Address	0:0:0:0:0:0:0:0
Subnet Mask	255.255.255.0
Gateway	192.168.2.1
DNS Server 1	8.8.8.8
DNS Server 2	208.67.222.222
PPPoE Link Up	Disabled

Figure 15: GXP2160 Web Access Using UCM6510 Port Forwarding

FIREWALL

The UCM6510 provides users firewall configurations to prevent certain malicious attack to the UCM6510 system. Users could configure to allow, restrict or reject specific traffic through the device for security and bandwidth purpose. The UCM6510 also provides Fail2ban feature for authentication errors in SIP REGISTER, INVITE and SUBSCRIBE.

To configure firewall settings in UCM6510, go to web GUI->**Settings**->**Firewall** page.

STATIC DEFENSE

Under web GUI->**Settings**->**Firewall**->**Static Defense** page, users will see the following information:

- Current service information with port, process and type.
- Typical firewall settings.
- Custom firewall settings.

The following table shows a sample current service status running on the UCM6510.

Table 9: UCM6510 Firewall->Static Defense->Current Service

Port	Process	Type
7777	Asterisk	tcp/IPv4
389	Slapd	tcp/IPv4
22	Dropbear	tcp/IPv4
80	Lighthttpd	tcp/IPv4
8089	Lighthttpd	tcp/IPv4
69	Opentftpd	udp/IPv4
9090	Asterisk	udp/IPv4
6060	zero_config	udp/IPv4
5060	Asterisk	udp/IPv4
4569	Asterisk	udp/IPv4
5353	zero_config	udp/IPv4
37435	Syslogd	udp/IPv4

For typical firewall settings, users could configure the following options on the UCM6510.

Table 10: Typical Firewall Settings

Ping Defense Enable	If enabled, ICMP response will not be allowed for Ping request. The default setting is disabled. To enable or disable it, click on the check box for the LAN or WAN interface.
SYN-Flood Defense Enable	Enable to prevent SYN Flood denial-of-service attack to the device. The default setting is disabled. To enable or disable it, click on the check box for the LAN or WAN interface.
Ping-of-Death Defense Enable	Enable to prevent Ping-of-Death attack to the device. The default setting is disabled. To enable or disable it, click on the check box for the LAN or WAN interface.

Under "Custom Firewall Settings", users could create new rules to accept, reject or drop certain traffic going through the UCM6510. To create new rule, click on "Create New Rule" button and a new window will pop up for users to specify rule options.

The following figure shows a firewall rule example that will deny SSH access for the UCM6510 from WAN side.





Figure 16: Create New Firewall Rule

Table 11: Firewall Rule Settings

Rule Name	Specify the Firewall rule name to identify the firewall rule.
Action	Select the action for the Firewall to perform. <ul style="list-style-type: none"> ACCEPT REJECT DROP
Type	Select the traffic type. <ul style="list-style-type: none"> IN

	<p>If selected, users will need specify the network interface "LAN", "WAN" or "Both" for the incoming traffic.</p> <ul style="list-style-type: none"> • OUT
Service	<p>Select the service type.</p> <ul style="list-style-type: none"> • FTP • SSH • Telnet • TFTP • HTTP • LDAP • Custom <p>If selected, users will need specify Source (IP and port), Destination (IP and port) and Protocol (TCP, UDP or Both) for the service. Please note if the source or the destination field is left blank, it will be used as "Anywhere".</p>

The new rule will be listed at the bottom of the page with sequence number, rule name, action, protocol, type, source, destination and operation. Users can click on  to edit the rule, or click on  to delete the rule. Save the change and reboot the device for the configuration to take effect.

DYNAMIC DEFENSE

Dynamic defense can blacklist hosts dynamically when the UCM6510 is set to "Route" under web GUI->**Settings->Network Settings->Basic Settings: Method**. If enabled, the traffic via TCP connection coming into the UCM6510 can be monitored, which helps prevent massive connection attempts or brute force attacks to the device. The blacklist can be created and updated by the UCM6510 firewall, which will then be displayed in the web page. Please refer to the following table for dynamic defense options on the UCM6510.

Table 12: UCM6510 Firewall Dynamic Defense

Dynamic Defense Enable	Enable dynamic defense. The default setting is disabled.
Periodical Time Interval	Configure the dynamic defense periodic time interval (in minutes). If the number of TCP connections from a host exceeds the "Connection Threshold" within this period, this host will be added into Blacklist. The valid value is between 1 and 59 when dynamic defense is turned on. The default setting is 59.

Blacklist Update Interval	Configure the blacklist update time interval (in seconds). The default setting is 120. This defines how long the IP will be blocked once added into the UCM6510 blacklist. For example, if it's set to 300 seconds, the blocked IP address will only be able to establish TCP connection with the UCM6510 again after 300 seconds.
Connection Threshold	Configure the connection threshold. Once the number of connections from the same host reaches the threshold during "Periodical Time Interval", it will be added into the blacklist. The default setting is 100.
Dynamic Defense Whitelist	Configure the dynamic defense whitelist. This is a list of IPs that will not be blocked by the UCM6510. For example, 192.168.1.3 192.168.1.4

The following figure shows a configuration example like this:

- If a host at IP address 192.168.40.7 initiates more than 20 TCP connections to the UCM6510 within 1 minute, it will be added into UCM6510 blacklist.
- This host 192.168.40.7 will be blocked by the UCM6510 for 300 seconds.
- Since IP address 192.168.40.5 is in whitelist, if the host at IP address 192.168.40.5 initiates more than 20 TCP connections to the UCM6510 within 1 minute, it will not be added into UCM6510 blacklist. It can still establish TCP connection with the UCM6510.

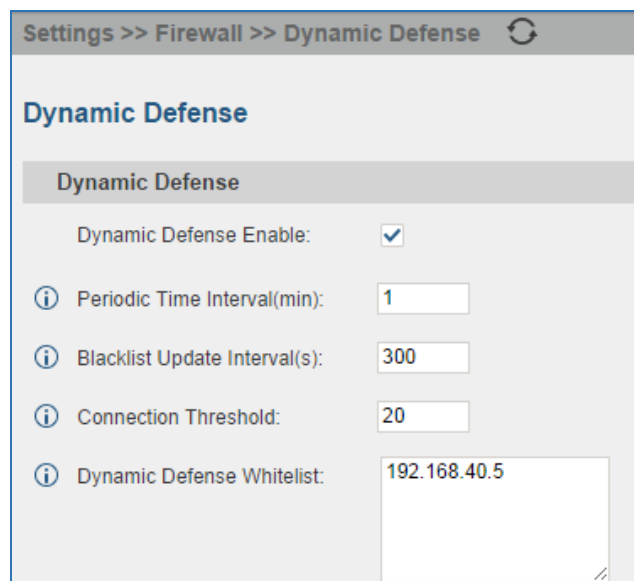

Figure 17: Configure Dynamic Defense

FAIL2BAN

Fail2Ban feature on the UCM6510 provides intrusion detection and prevention for authentication errors in SIP REGISTER, INVITE and SUBSCRIBE. Once the entry is detected within "Max Retry Duration", the UCM6510 will take action to forbid the host for certain period as defined in "Banned Duration". This feature helps prevent SIP brute force attacks to the PBX system.

Table 13: Fail2Ban Settings

Global Settings	
Enable Fail2Ban	Enable Fail2Ban. The default setting is disabled. Please make sure both "Enable Fail2Ban" and "Asterisk Service" are turned on in order to use Fail2Ban for SIP authentication on the UCM6510.
Banned Duration	Configure the duration (in seconds) for the detected host to be banned. The default setting is 300. If set to -1, the host will be always banned.
Max Retry Duration	Within this duration (in seconds), if a host exceeds the max times of retry as defined in "MaxRetry", the host will be banned. The default setting is 5.
MaxRetry	Configure the number of authentication failures during "Max Retry Duration" before the host is banned. The default setting is 10.
Fail2Ban Whitelist	Configure IP address, CIDR mask or DNS host in the whitelist. Fail2Ban will not ban the host with matching address in this list. Up to 5 addresses can be added into the list.
Local Settings	
Asterisk Service	Enable Asterisk service for Fail2Ban. The default setting is disabled. Please make sure both "Enable Fail2Ban" and "Asterisk Service" are turned on in order to use Fail2Ban for SIP authentication on the UCM6510.
Port	Configure the listening port number for the service. Currently only 5060 (for UDP) is supported.
MaxRetry	Configure the number of authentication failures during "Max Retry Duration" before the host is banned. The default setting is 10. Please make sure this option is properly configured as it will override the "MaxRetry" value under "Global Settings".

CHANGE PASSWORD

After logging in the web GUI for the first time, it is highly recommended for users to change the default password "admin" to a more complicated password for security purpose. Follow the steps below to change the web GUI access password.

1. Go to web GUI->**Settings->Change Password** page.
2. Enter the old password first.
3. Enter the new password and retype the new password to confirm. The new password has to be at least 4 characters. The maximum length of the password is 16 characters.
4. Click on "Save" and the user will be automatically logged out.
5. Once the web page comes back to the login page again, enter the username "admin" and the new password to login.

LDAP SERVER

The UCM6510 has an embedded LDAP server for users to manage corporate phonebook in a centralized manner.

- By default, the LDAP server has generated the first phonebook with **PBX DN** "ou=pbx,dc=pbx,dc=com" based on the UCM6510 user extensions already.
- Users could add new phonebook with a different **Phonebook DN** for other external contacts. For example, "ou=people,dc=pbx,dc=com".
- All the phonebooks in the UCM6510 LDAP server have the same **Base DN** "dc=pbx,dc=com".

If users have the Grandstream phone provisioned by the UCM6510, the LDAP directory has been set up on the phone and can be used right away for users to access all phonebooks.

Additionally, users could manually configure the LDAP client settings to manipulate the built-in LDAP server on the UCM6510. If the UCM6510 has multiple LDAP phonebooks created, in the LDAP client configuration, users could use "dc=pbx,dc=com" as Base DN to have access to all phonebooks on the UCM6510 LDAP server, or use a specific phonebook DN, for example "ou=people,dc=pbx,dc=com", to access to phonebook with Phonebook DN "ou=people,dc=pbx,dc=com " only.

To access LDAP Server settings, go to **web GUI->Settings->LDAP Server**.

LDAP SERVER CONFIGURATIONS

The following figure shows the default LDAP server configurations on the UCM6510.

LDAP Server configurations

Base DN:

PBX DN:

Root DN:

Root Password:

Confirm Root Password:

Figure 18: LDAP Server Configurations

The UCM6510 LDAP server supports anonymous access (read-only) by default. Therefore the LDAP client doesn't have to configure username and password to access the phonebook directory. The "Root DN" and "Root Password" here are for LDAP management and configuration where users will need provide for authentication purpose before modifying the LDAP information.

The default phonebook list in this LDAP server can be viewed and edited by clicking on  for the first phonebook under LDAP Phonebook.



No.	Phonebook DN	Options
1	ou=pbx,dc=pbx,dc=com	 

Figure 19: Default LDAP Phonebook DN

Edit Phonebook: ou=pbx,dc=pbx,dc=com

LDAP Attributes		Contact List	
AccountNumber:	5000	AccountNumber	CallerIDName
CallerIDName:	John Doe	5000	John Doe
Email:		5001	Stacy Green
FirstName:		5002	Tom Lin
LastName:		5003	Ricky Chan
Department:		5004	Front Desk
MobileNumber:		5005	Warehouse
HomeNumber:		5006	Sales
Fax:		5007	Tech Support
		5008	Customer Service
		5009	RMA
		5010	Shipping
		5011	Test

Cancel

Figure 20: Default LDAP Phonebook Attributes

LDAP PHONEBOOK

Users could use the default phonebook, edit the default phonebook as well as add new phonebook on the LDAP server. The first phonebook with default phonebook dn "ou=pbx,dc=pbx,dc=com" displayed on the LDAP server page is for extensions in this PBX. Users cannot add or delete contacts directly. The contacts information will need to be modified via web GUI->**PBX->Basic/Call Routes->Extensions** first. The default LDAP phonebook will then be updated automatically.

A new sibling phonebook of the default PBX phonebook can be added by clicking on "Add" under "LDAP Phonebook" section.

Add Phonebook



Phonebook Prefix:

Phonebook DN:

Cancel Save

Figure 21: Add LDAP Phonebook

Configure the "Phonebook Prefix" first. The "Phonebook DN" will be automatically filled in. For example, if configuring "Phonebook Prefix" as "people", the "Phonebook DN" will be filled with "ou=people,dc=pbx,dc=com".

Once added, users can select  to edit the phonebook attributes and contact list (see figure below), or select  to delete the phonebook.

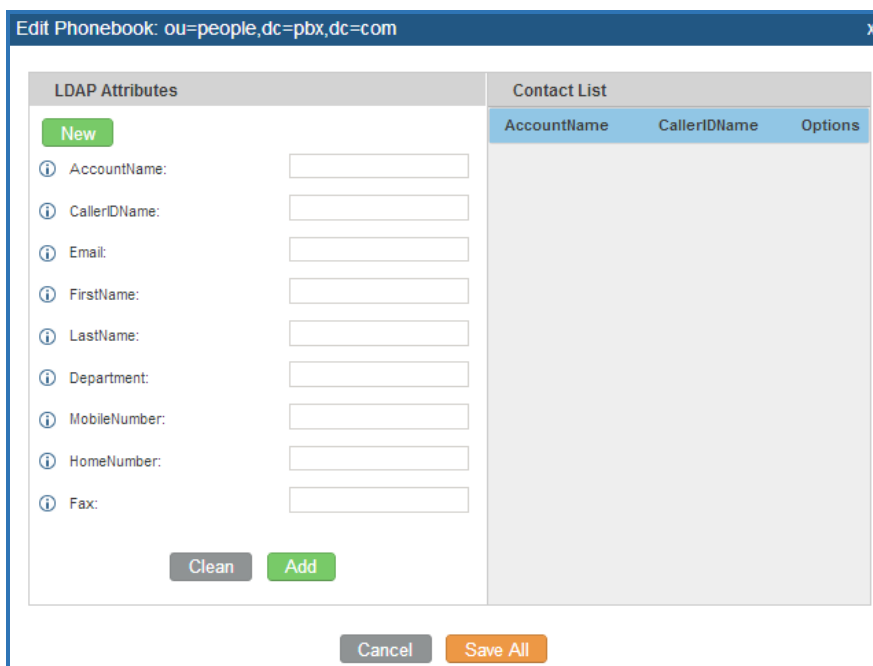

Figure 22: Edit LDAP Phonebook

LDAP CLIENT CONFIGURATIONS

The configuration on LDAP client is similar when you use other LDAP servers. Here we provide an example on how to configure the LDAP client on the SIP end points to use the default PBX phonebook.

Assuming the server base dn is "dc=pbx,dc=com", configure the LDAP clients as follows (case insensitive):

Base DN: dc=pbx,dc=com

Login DN: Please leave this field empty

Password: Please leave this field empty

Anonymous: Please enable this option

Filter: ((CallerIDName=%)(AccountNumber=%))

Port: 389

To configure Grandstream IP phones as the LDAP client, please refer to the following example:

Server Address: The IP address or domain name of the UCM6510

Base DN: dc=pbx,dc=com

User Name: Please leave this field empty

Password: Please leave this field empty

LDAP Name Attribute: CallerIDName Email Department FirstName LastName

LDAP Number Attribute: AccountNumber MobileNumber HomeNumber Fax

LDAP Number Filter: (AccountNumber=%)

LDAP Name Filter: (CallerIDName=%)

LDAP Display Name: AccountNumber CallerIDName

LDAP Version: If existed, please select LDAP Version 3

Port: 389

The following figure shows the configuration information on a Grandstream GXP2200 to successfully use the LDAP server as configured in **[Figure 18: LDAP Server Configurations]**.

Server Address :	<input type="text" value="192.168.40.134"/>
Port :	<input type="text" value="389"/>
Base DN :	<input type="text" value="dc=pbx,dc=com"/>
User Name :	<input type="text"/>
Password :	<input type="password"/>
LDAP Name Attributes :	<input type="text" value="CallerIDName"/>
LDAP Number Attributes :	<input type="text" value="AccountNumber"/>
LDAP Mail Attributes :	<input type="text"/>
LDAP Name Filter :	<input type="text" value="(CallerIDName=%)"/>
LDAP Number Filter :	<input type="text" value="(AccountNumber=%)"/>
LDAP Mail Filter :	<input type="text"/>
LDAP Displaying Name Attributes :	<input type="text" value="%AccountNumber %CallerIDName"/>
Max Hits :	<input type="text" value="50"/>
Search Timeout(ms) :	<input type="text" value="0"/>
LDAP Lookup For Dial :	<input type="checkbox"/> Enable
LDAP Lookup For Incoming Call :	<input type="checkbox"/> Enable

Figure 23: GXP2200 LDAP Phonebook Configuration

HTTP SERVER

The UCM6510 embedded web server responds to HTTP/HTTPS GET/POST requests. Embedded HTML pages allow the users to configure the PBX through a web browser such as Microsoft IE, Mozilla Firefox and Google Chrome. By default, the PBX can be accessed directly by typing IP address in the PC's web browser (e.g., 192.168.40.50). It will then be automatically redirected to HTTPS using Port 8089 (e.g., https://192.168.40.50:8089). Users could also change the access protocol and port as preferred under web GUI->**Settings->HTTP Server**.

Table 14: HTTP Server Settings

Redirect From Port 80	Enable or disable redirect from port 80. On the PBX, the default access protocol is HTTPS and the default port number is 8089. When this option is enabled, the access using HTTP with Port 80 will be redirected to HTTPS with Port 8089. The default setting is "Enable".
Protocol Type	Select HTTP or HTTPS as the protocol to access the HTTP server. The default setting is "HTTPS". This also defines whether to use HTTP or HTTPS to download the config file in zero config as the UCM6510 is served as HTTP/HTTPS server that has the device config files for zero config.
Port	Specify port number to access the HTTP server. The default port number is 8089.

Once the change is saved, the web page will be redirected to the login page using the new URL. Enter the username and password to login again.

EMAIL SETTINGS

The Email application on the UCM6510 can be used to send out alert event Emails, Fax (Fax-To-Email), Voicemail (Voicemail-To-Email) and etc. The configuration parameters can be accessed via web GUI->**Settings->Email Settings**.

Table 15: Email Settings

TLS Enable	Enable or disable TLS during transferring/submitted your Email to other SMTP server. The default setting is "Yes".
Type	<ul style="list-style-type: none"> • MTA: Mail Transfer Agent. The Email will be sent from the configured domain. When MTA is selected, there is no need to set up SMTP server for it or no user login is required. However, the Emails sent from MTA might be considered as spam by the target SMTP server. • Client: Submit Emails to the SMTP server. A SMTP server is required and users need login with correct credentials.
Domain	Specify the domain name to be used in the Email when using type "MTA".
Server	Specify the SMTP server when using type "Client". For example, if using Gmail as the SMTP server, you can configure it as <i>smtp.gmail.com:465</i> .
Username	Username is required when using type "Client". Normally it's the Email address.

Password	Password to log in for the above Username (Email address) is required when using type "Client".
Display Name	Specify the display name in the FROM header in the Email.
Sender	Specify the sender's Email address. For example, pbx@example.mycompany.com.

The following figure shows a sample Email settings on the UCM6510, assuming the Email is using *smtp.gmail.com* as the SMTP server and the port number is 465.

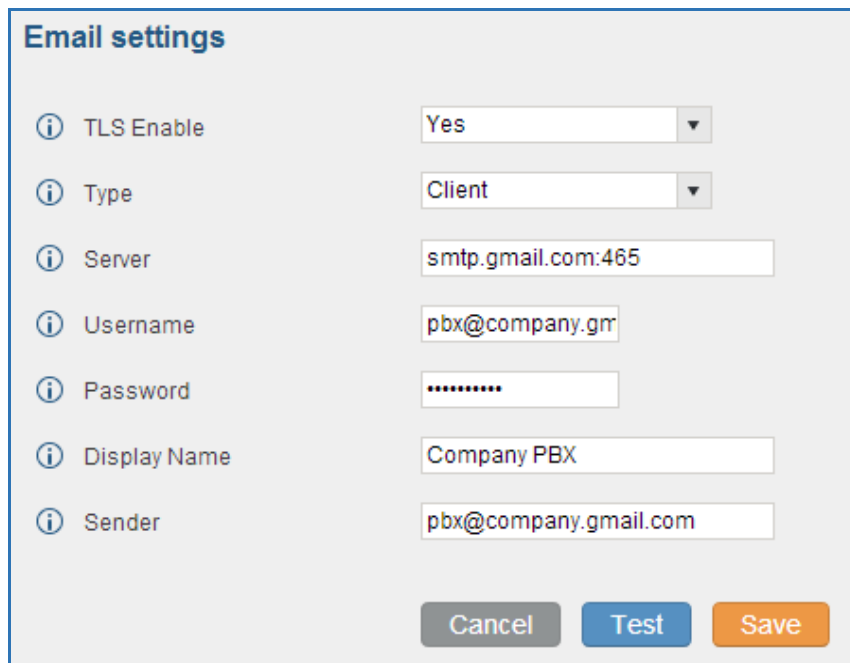

Figure 24: UCM6510 Email Settings

Once the configuration is finished, click on "Save" first. Then click on "Test" button to make sure the Email setting is working.

The following figure shows the new dialog prompted to test the Email setting. Fill in a valid Email address to send a test Email to verify the Email settings on the UCM6510.

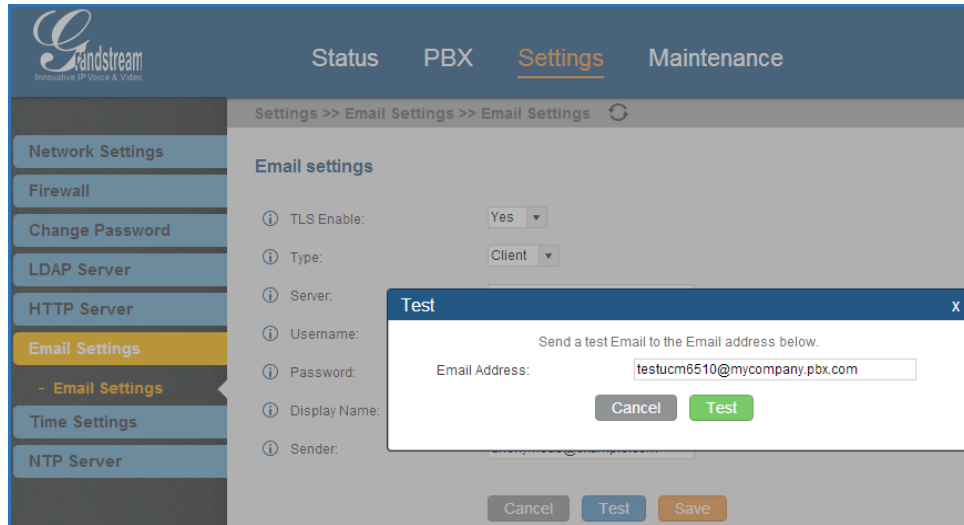

Figure 25: UCM6510 Email Settings: Send Test Email

TIME SETTINGS

AUTO TIME UPDATING

The current system time on the UCM6510 is displayed on the upper right of the web page. It can also be found under web GUI->**Status**->**System Status**->**General**.

To configure the UCM6510 to update time automatically, go to web GUI->**Settings**->**Time Settings**->**Auto Time Updating**.

Note:

The configurations under Web GUI->**Settings**->**Time Settings**->**Time Auto Updating** page require reboot to take effect. Please consider configuring auto time updating related changes when setting up the UCM6510 for the first time to avoid service interrupt after installation and deployment in production.

Table 16: Auto Time Updating

Remote NTP Server	Specify the URL or IP address of the NTP server for the UCM6510 to synchronize the date and time. The default NTP server is ntp.ipvideotalk.com.
Enable DHCP Option 2	If set to "Yes", the UCM6510 is allowed to get provisioned for Time Zone from DHCP Option 2 in the local server automatically. The default setting is "Yes".
Enable DHCP Option 42	If set to "Yes", the UCM6510 is allowed to get provisioned for NTP Server from DHCP Option 42 in the local server automatically. This will override the manually configured NTP Server. The default setting is "Yes".
Time Zone	<p>Select the proper time zone option so the UCM6510 can display correct time accordingly.</p> <p>If "Self-Defined Tome Zone" is selected, please specify the time zone parameters in "Self-Defined Time Zone" field as described in below option.</p>
Self-Defined Time Zone	<p>If "Self-Defined Time Zone" is selected in "Time Zone" option, users will need define their own time zone following the format below.</p> <p>The syntax is: std offset dst [offset], start [/time], end [/time]</p> <p>Default is set to: MTZ+6MDT+5,M4.1.0,M11.1.0</p> <p>MTZ+6MDT+5 This indicates a time zone with 6 hours offset and 1 hour ahead for DST, which is U.S central time. If it is positive (+), the local time zone is west of the Prime Meridian (A.K.A: International or Greenwich Meridian); If it is negative (-), the local time zone is east.</p> <p>M4.1.0,M11.1.0 The 1st number indicates Month: 1, 2, 3..., 12 (for Jan, Feb...Dec.). The 2nd number indicates the nth iteration of the weekday: (1st Sunday, 3rd Tuesday...). Normally 1, 2, 3, 4 are used. If 5 is used, it means the last iteration of the weekday. The 3rd number indicates weekday: 0, 1, 2...6 (for Sun, Mon, Tues... Sat). Therefore, this example is the DST which starts from the First Sunday of April to the 1st Sunday of November.</p>

SET TIME MANUALLY

To manually set the time on the UCM6510, go to Web GUI->**Settings->Time Settings->Set Time Manually**. The format is YYYY-MM-DD HH:MI:SS.

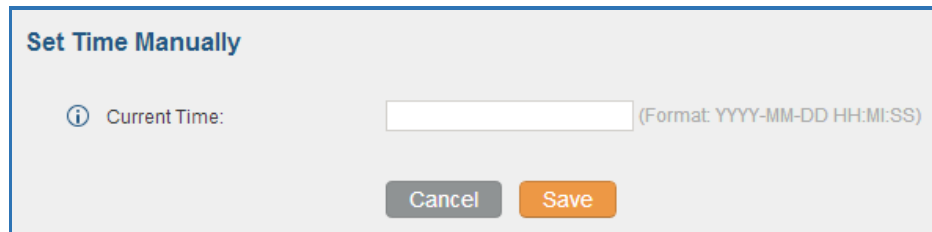

The screenshot shows a web form titled "Set Time Manually". It features a label "Current Time:" with an information icon to its left. To the right of the label is a text input field. Further right, the text "(Format: YYYY-MM-DD HH:MI:SS)" is displayed. Below the input field are two buttons: a grey "Cancel" button and an orange "Save" button.

Figure 26: Set Time Manually

 **Note:**

Manually setup time will take effect immediately after saving and applying change in the web UI. If users would like to reboot the UCM6510 and keep the manually setup time setting, please make sure "Remote NTP Server", "Enable DHCP Option 2" and "Enable DHCP Option 42" options under Web GUI->**Settings->Time Settings->Time Auto Updating** page are unchecked or set to empty. Otherwise, time auto updating settings in this page will take effect after reboot.

NTP SERVER

The UCM6510 can be used as a NTP server for the NTP clients to synchronize their time with. To configure the UCM6510 as the NTP server, set "Enable NTP server" to "Yes" under web GUI->**Settings->Time Settings->NTP Server**. On the client side, point the NTP server address to the UCM6510 IP address or host name to use the UCM6510 as the NTP server.

PROVISIONING

OVERVIEW

Grandstream SIP Devices can be configured via web interface as well as via configuration file through TFTP/HTTP/HTTPS download. All Grandstream SIP devices support a proprietary binary format configuration file and XML format configuration file. The UCM6510 provides a Plug and Play mechanism to auto-provision the Grandstream SIP devices in a zero configuration manner by generating XML config file and having the phone to download it within LAN area. This allows users to finish the installation with ease and start using the SIP devices in a managed way.

To provision a phone, three steps are involved, i.e., discovery, assignment and provisioning. The UCM6510 creates XML config file to the detected/assigned Grandstream device and accomplishes the following configurations on the device after the provisioning:

- A UCM6510 extension will be assigned and registered on the phone.
- SIP-related network settings such as "NAT traversal" and "Use Random Port" are configured on the phone.
- Call feature settings such as "Public Mode", "Voicemail User ID", "Dial Plan" and "Auto Answer".
- LDAP client configurations will be set up automatically on the phone to use the default LDAP directory generated in the UCM6510 LDAP server.

This section explains how zero config works on the UCM6510. The settings for this feature can be accessed via web GUI->**PBX->Basic/Call Routes->Zero Config**.

AUTO PROVISIONING

By default, the Zero Config feature is enabled on the UCM6510 for auto provisioning. Three methods of auto provisioning are used.

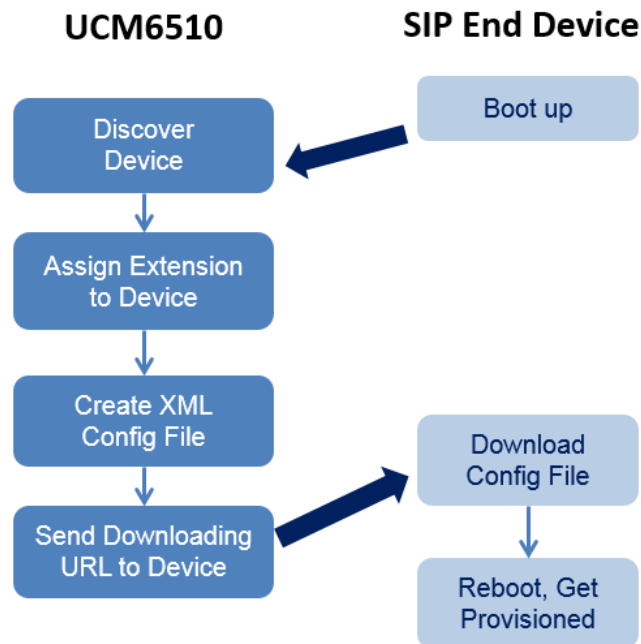

Figure 27: UCM6510 Zero Config

- **SIP SUBSCRIBE**

When the phone boots up, it sends out SUBSCRIBE to a multicast IP address in the LAN. The UCM6510 discovers it and then sends a NOTIFY with the XML config file URL in the message body. The phone will then use the path to download the config file generated in the UCM6510 and reboot again to take the new configuration.

- **DHCP OPTION 66**

This method should be used only when the UCM6510 is set to "Route" mode under web GUI->**Settings->Network Settings->Basic Settings**: Method. When the phone restarts (by default DHCP Option 66 is turned on), it will send out a DHCP DISCOVER request. The UCM6510 receives it and returns DHCP OFFER with the config server path URL in the Option 66, for example, <https://192.168.2.1:8089/zccgi/>. The phone will then use the path to download the config file generated in the UCM6510.

- **mDNS**

When the phone boots up, it sends out mDNS query to get the TFTP server address. The UCM6510 will respond with its own address. The phone will then send TFTP request to download the XML config file from the UCM6510.

To start the auto provisioning process, under web GUI->**PBX->Basic/Call Routes->Zero Config**, click on "Auto Provision Settings" and fill in the auto provision information.

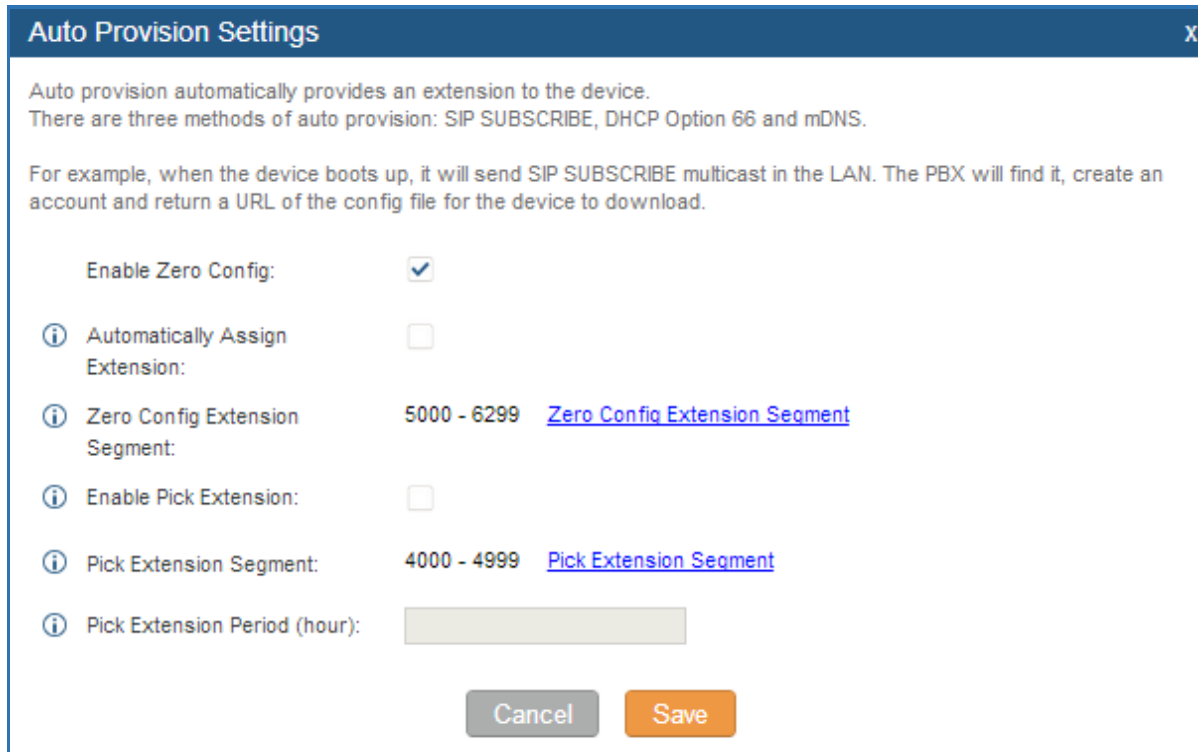

Figure 28: Auto Provision Settings

Table 17: Auto Provision Settings

Enable Zero Config	Enable or disable the zero config feature on the PBX. The default setting is enabled.
Automatically Assign Extension	If enabled, when the device is discovered, the PBX will automatically assign an extension within the range defined in "Zero Config Extension Segment" to the device. The default setting is disabled.
Zero Config Extension Segment	Click on the link "Zero Config Extension Segment" to specify the extension range to be assigned if "Automatically Assign Extension" is enabled. The default range is 5000-6299. Zero Config Extension Segment range can be defined in web UI-> PBX->Internal Options->General page->Extension Preference section: "Auto Provision Extensions".
Enable Pick Extension	If enabled, the extension list will be sent out to the device after receiving the device's request. This feature is for the GXP series phones that support selecting extension to be provisioned via phone's LCD. The default setting is disabled.

Pick Extension Segment	Click on the link "Pick Extension Segment" to specify the extension list to be sent to the device. The default range is 4000 to 4999. Pick Extension Segment range can be defined in web UI-> PBX -> Internal Options -> General page->Extension Preference section: "Pick Extensions".
Pick Extension Period (hour):	Specify the number of minutes to allow the phones being provisioned to pick extensions.

Please make sure an extension is manually assigned to the phone or "Automatically Assign Extension" is enabled during provisioning. After the configuration on the UCM6510 web GUI, click on "Save" and "Apply Changes". Once the phone boots up and picks up the config file from the UCM6510, it will take the configuration right away.

MANUAL PROVISIONING

DISCOVERY

Users could manually discover the device by specifying the IP address or scanning the entire LAN network. Three methods are supported to scan the devices.

- PING
- ARP
- SIP Message (NOTIFY)

Click on "Auto Discover", fill in the "Scan Method" and "Scan IP". The IP address segment will be automatically filled in based on the network mask detected on the UCM6510. If users need scan the entire network segment, enter 255 (for example, 192.168.40.255) instead of a specific IP address. Then click on "Save" to start discovering the devices within the same network. To successfully discover the devices, "Zero Config" needs to be enabled on the UCM6510 web GUI->**PBX**->**Basic/Call Routes**->**Zero Config**->**Auto Provisioning Settings**.



Figure 29: Auto Discover

The following figure shows a list of discovered phones. The MAC address, IP Address, Extension (if assigned), Version, Vendor, Model, Connection Status, Create Config, Options (Edit/Delete/Update) are displayed in the list.

72.	000B822B2D94	192.168.40.143		1.0.5.26	Grandstream	GXP2110	Connected	No			
107.	000B82273BE4	--		1.0.5.26	Grandstream	GXP2110	Connected	No			
94.	000B822B1B29	--		1.0.5.26	Grandstream	GXP2100	Connected	No			
108.	000B822A852C	192.168.40.3		1.0.4.9	Grandstream	GXP2100	Connected	No			
28.	000B82382BE7	--		1.0.5.32	Grandstream	GXP1450	Connected	No			
36.	000B82382FFB	--		1.0.5.26	Grandstream	GXP1450	Connected	No			
75.	000B8233A045	--		1.0.5.24	Grandstream	GXP1450	Connected	No			

Figure 30: Discovered Devices

ASSIGNMENT

In the discovered list, click on  to open the edit dialog to assign an extension or multiple extensions to this device. Hot-Desking can also be enabled from this edit page.

Edit Device : 000B822B2D94

Enable Hot-Desking:

 MAC Address:

 IP Address:

 Version:

 Model:

 Account Select:

Account 1: 

Account 2: 

Account 3: 



Account 4: 

Figure 31: Assign Extension To Device

After saving the edit dialog, the XML config file will be generated in the UCM6510. Reboot the phone or trigger the phone to download the config file by clicking on  icon for the entry in the zero config device list.

CREATE NEW DEVICE

Users could also directly create a new device and assign the extension before the device is discovered by the UCM6510. Once the device is plugged in, it can then be discovered and provisioned by the UCM6510.

Click on "Create New Device" and the following dialog will show. Enabled Hot-Desking (optional), fill in the MAC address (required), IP address (optional), Version (optional), Model (optional) and the extension (required) to assign to the device. Click on "Save" to add the device to the provision list.

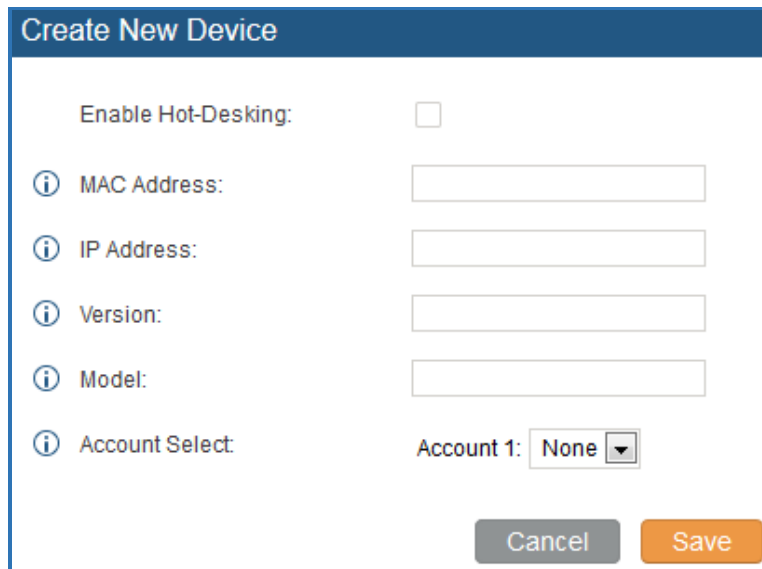

The screenshot shows a dialog box titled "Create New Device". It contains the following elements:

- Enable Hot-Desking:** A checkbox that is currently unchecked.
- MAC Address:** A text input field with an information icon (i) to its left.
- IP Address:** A text input field with an information icon (i) to its left.
- Version:** A text input field with an information icon (i) to its left.
- Model:** A text input field with an information icon (i) to its left.
- Account Select:** A dropdown menu with "Account 1:" and "None" selected.
- Buttons:** "Cancel" (grey) and "Save" (orange) buttons at the bottom right.

Figure 32: Create New Device

PROVISIONING

After the successful discovery and assignment configuration on the UCM6510, the device will start downloading the config file and take the new configuration with the extension registered.

EXTENSIONS

CREATE NEW USER

CREATE NEW SIP EXTENSION

To manually create new SIP user, go to web GUI->**PBX->Basic/Call Routes->Extensions**. Click on "Create New User"->"Create New SIP Extension" and a new dialog window will show for users to fill in the extension information. The configuration parameters are as follows.

Table 18: SIP Extension Configuration Parameters

General	
Extension	The extension number associated with the user. This is the SIP UserID for registration.
CallerID Number	Configure the CallerID Number that would be applied for outgoing calls from this user. Note: The ability to manipulate your outbound Caller ID may be limited by your VoIP provider.
Permission	Assign permission level to the user. The available permissions are "Internal", "Local", "National" and "International" from the lowest level to the highest level. The default setting is "Internal". Note: Users need to have the same level as or higher level than an outbound rule's privilege in order to make outbound calls using this rule. If the outbound rule privilege is disabled, this option will not take effect.
SIP/IAX Password	Configure the password for the user. A random secure password will be automatically generated when the extension is created. It is recommended to use this password or other strong password for security purpose.
Enable Voicemail	Enable voicemail for the user so that the call will be forwarded to the user's voicemail if there is no answer or the call is rejected. The default setting is "Yes".
Voicemail Password	Configure voicemail password (digits only) for the user to access the voicemail box. A random numeric password is automatically generated when the extension is created. It is recommended to use the random

	generated password for security purpose.
Call Forward Unconditional	Configure the Call Forward Unconditional target number so that the incoming call to this extension will be always forwarded to the target number. If not configured, the Call Forward Unconditional feature is deactivated. The default setting is deactivated.
Call Forward No Answer	Configure the Call Forward No Answer target number so that the incoming call to this extension will be forwarded to the target number if the call is not answered until the ringing times out. If not configured, the Call Forward No Answer feature is deactivated. The default setting is deactivated.
Call Forward Busy	Configure the Call Forward Busy target number so that the incoming call to this extension will be forwarded to the target number if the call is rejected or the extension is in talking/busy status. If not configured, the Call Forward Busy feature is deactivated. The default setting is deactivated.
Ring Timeout	<p>Configure the number of seconds to ring the user before the call is forwarded to voicemail (voicemail is enabled) or hang up (voicemail is disabled). If not specified, the default ring timeout is 60 seconds on the UCM6510, which can be configured in the global ring timeout setting under web GUI->Internal Options: General Preference. The valid range is between 5 seconds and 600 seconds.</p> <p>Note: If the end point also has a ring timeout configured, the actual ring timeout used is the shortest time set by either device.</p>
Auto Record	Enable automatic recording for the calls using this extension. The default setting is disabled. The recording files will be saved in external storage if plugged in and can be accessed under web GUI-> CDR -> Recording Files .
Skip Voicemail Password Verification	When user dials voicemail code, the password verification IVR is skipped. If enabled, this would allow one-button voicemail access. By default this option is disabled.
Support Hot-Desking Mode	This mode can be used for devices that support hot-desking feature. For example, the GXP21xx series phones support hot-desking feature by turning on “Public Mode”. On the device, users can log in and log out using the SIP UserID and password. If enabled on the UCM6510, the SIP Password for the extension will accept only alphabet characters and digits; AuthID will also be changed to the same as Extension.

User Settings

First Name	Configure the first name of the user. The first name can contain characters, letters, digits and _.
Last Name	Configure the last name of the user. The last name can contain characters, letters, digits and _.
Email Address	Fill in the Email address for the user. Voicemail will be sent to this Email address.
Language	Select the voice prompt language to be used for this extension. The default setting is "Default" which is the selected voice prompt language under web GUI-> PBX->Internal Options->Language . The dropdown list shows all the current available voice prompt languages on the UCM6510. To add more languages in the list, please download voice prompt package by selecting "Check Prompt List" under web GUI-> PBX->Internal Options->Language .
SIP Settings	
NAT	Use NAT when the UCM6510 is on a public IP communicating with devices hidden behind NAT (e.g., broadband router). If there is one-way audio issue, usually it's related to NAT configuration or Firewall's support of SIP and RTP ports. The default setting is enabled.
Can Reinvite	By default, the UCM6510 will route the media streams from SIP endpoints through itself. If enabled, the PBX will attempt to negotiate with the endpoints to route the media stream directly. It is not always possible for the UCM6510 to negotiate endpoint-to-endpoint media routing. The default setting is "No".
DTMF Mode	Select DTMF mode for the user to send DTMF. The default setting is "RFC2833". If "Info" is selected, SIP INFO message will be used. If "Inband" is selected, 64-kbit PCMU and PCMA are required. When "Auto" is selected, RFC2833 will be used if offered, otherwise "Inband" will be used.
Insecure	<ul style="list-style-type: none"> Port: Allow peers matching by IP address without matching port number. Very: Allow peers matching by IP address without matching port number. Also, authentication of incoming INVITE messages is not required. No: Normal IP-based peers matching and authentication of incoming INVITE. <p>The default setting is "Port".</p>
Enable Keep-alive	If enabled, empty SDP packet will be sent to the SIP server periodically to keep the NAT port open. The default setting is "Yes".

Keep-alive Frequency	Configure the Keep-alive interval (in seconds) to check if the host is up. The default setting is 60 seconds.
Auth ID	Configure the authentication ID for the user. If not configured, the extension number will be used for authentication.
Other Settings	
S RTP	Enable S RTP for the call. The default setting is disabled.
Fax Detection	<p>Enable to detect Fax signal from the user/trunk during the call and send the received Fax to the Email address configured for this extension. If no Email address can be found for the user, send the received Fax to the default Email address in Fax setting page under UCM6510 web GUI->PBX->Internal Options->Fax/T.38.</p> <p>Note: If enabled, Fax Pass-through cannot be used.</p>
Strategy	<p>This option controls how the extension can be used on devices within different types of network.</p> <ul style="list-style-type: none"> • Allow All Device in any network can register this extension. • Local Subnet Only Only the user in specific subnet can register this extension. Up to three subnet addresses can be specified. • A Specific IP Address Only the device on the specific IP address can register this extension. <p>The default setting is "Allow All".</p>
Skip Trunk Auth	If enabled, users will not need enter the "PIN Set" required by the outbound rule to make outbound calls. The default setting is "No".
Codec Preference	Select audio and video codec for the extension. The available codecs are: PCMU, PCMA, GSM, AAL2-G.726-32, G.726, G.722, G.729, G.723, ILBC, ADPCM, H.264, H.263 and H.263p. In the selected codec list, users can click on UP or DOWN arrow to adjust the order for the codec priority.

CREATE NEW IAX EXTENSION

To manually create new IAX user, go to web GUI->**PBX->Basic/Call Routes->Extensions**. Click on "Create New User"->"Create New IAX Extension" and a new dialog window will show for users to fill in the extension information. The configuration parameters are as follows.

Table 19: IAX Extension Configuration Parameters

General	
Extension	The extension number associated with the user.
CallerID Number	<p>Configure the CallerID Number that would be applied for outgoing calls from this user.</p> <p>Note: The ability to manipulate your outbound Caller ID may be limited by your VoIP provider.</p>
Permission	<p>Assign permission level to the user. The available permissions are "Internal", "Local", "National" and "International" from the lowest level to the highest level. The default setting is "Internal".</p> <p>Note: Users need to have the same level as or higher level than an outbound rule's privilege in order to make outbound calls using this rule. If the outbound rule privilege is disabled, this option will not take effect.</p>
SIP/IAX Password	Configure the password for the user. A random secure password will be automatically generated when the extension is created. It is recommended to use this password or other strong password for security purpose.
Enable Voicemail	Enable voicemail for the user. The default setting is "Yes".
Voicemail Password	Configure voicemail password (digits only) for the user to access the voicemail box. A random numeric password is automatically generated. It is recommended to use the random generated password for security purpose.
Call Forward Unconditional	Configure the Call Forward Unconditional target number so that the incoming call to this extension will be always forwarded to the target number. If not configured, the Call Forward Unconditional feature is deactivated. The default setting is deactivated.
Call Forward No Answer	Configure the Call Forward No Answer target number so that the incoming call to this extension will be forwarded to the target number if the call is not answered until the ringing times out. If not configured, the Call Forward No Answer feature is deactivated. The default setting is deactivated.
Call Forward Busy	Configure the Call Forward Busy target number so that the incoming call to this extension will be forwarded to the target number if the call is rejected or the extension is in talking/busy status. If not configured, the Call Forward Busy feature is deactivated. The default setting is

	deactivated.
Ring Timeout	<p>Configure the number of seconds to ring the user before the call is forwarded to voicemail (voicemail is enabled) or hang up (voicemail is disabled). If not specified, the default ring timeout is 60 seconds on the UCM6510, which can be configured in the global ring timeout setting under web GUI->Internal Options: General Preference. The valid range is between 5 seconds and 600 seconds.</p> <p>Note: If the end point also has a ring timeout configured, the actual ring timeout used is the shortest time set by either device.</p>
Auto Record	<p>Enable automatic recording for the calls using this extension. The default setting is disabled. The recording files will be saved in external storage if plugged in and can be accessed under web GUI->CDR->Recording Files.</p>
Skip Voicemail Password Verification	<p>When user dials voicemail code, the password verification IVR is skipped. If enabled, this would allow one-button voicemail access. By default this option is disabled.</p>
User Settings	
First Name	<p>Configure the first name of the user. The first name can contain characters, letters, digits and _.</p>
Last Name	<p>Configure the last name of the user. The last name can contain characters, letters, digits and _.</p>
Email Address	<p>Fill in the Email address for the user. Voicemail will be sent to this Email address.</p>
Language	<p>Select the voice prompt language to be used for this extension. The default setting is "Default" which is the selected voice prompt language under web GUI->PBX->Internal Options->Language. The dropdown list shows all the current available voice prompt languages on the UCM6510. To add more languages in the list, please download voice prompt package by selecting "Check Prompt List" under web GUI->PBX->Internal Options->Language.</p>
IAX Settings	
Max Number of Calls	<p>Configure the maximum number of calls allowed for each remote IP address.</p>
Require Call Token	<p>Configure to enable/disable requiring call token. If set to "Auto", it might lock out users who depend on backward compatibility when peer authentication credentials are shared between physical endpoints. The default setting is "Yes".</p>

Other Settings	
S RTP	Enable SRTP for the call. The default setting is disabled.
Fax Detection	<p>Enable to detect Fax signal from the user/trunk during the call and send the received Fax to the Email address configured for this extension. If no Email address can be found for the user, send the received Fax to the default Email address in Fax setting page under web GUI->PBX->Internal Options->Fax/T.38.</p> <p>Note: If enabled, Fax Pass-through cannot be used.</p>
Strategy	<p>This option controls how the extension can be used on devices within different types of network.</p> <ul style="list-style-type: none"> • Allow All Device in any network can register this extension. • Local Subnet Only Only the user in specific subnet can register this extension. Up to three subnet addresses can be specified. • A Specific IP Address Only the device on the specific IP address can register this extension. <p>The default setting is "Allow All".</p>
Skip Trunk Auth	If enabled, users will not need enter the "PIN Set" required by the outbound rule to make outbound calls. The default setting is "No".
Codec Preference	Select audio and video codec for the extension. The available codecs are: PCMU, PCMA, GSM, AAL2-G.726-32, G.726, G.722, G.729, G.723, ILBC, ADPCM, H.264, H.263 and H.263p. In the selected codec list, users can click on UP or DOWN arrow to adjust the order for the codec priority.

CREATE NEW FXS EXTENSION

To manually create new FXS user, go to web GUI->**PBX->Basic/Call Routes->Extensions**. Click on "Create New User"->"Create New FXS Extension" and a new dialog window will show for users to fill in the extension information. The configuration parameters are as follows.

Table 20: FXS Extension Configuration Parameters

General	
Extension	The extension number associated with the user.

Analog Station	Select the FXS port to be assigned for this extension.
CallerID Number	<p>Configure the CallerID Number that would be applied for outgoing calls from this user.</p> <p>Note: The ability to manipulate your outbound Caller ID may be limited by your VoIP provider.</p>
Permission	<p>Assign permission level to the user. The available permissions are "Internal", "Local", "National" and "International" from the lowest level to the highest level. The default setting is "Internal".</p> <p>Note: Users need to have the same level as or higher level than an outbound rule's privilege in order to make outbound calls using this rule. If the outbound rule privilege is disabled, this option will not take effect.</p>
Enable Voicemail	Enable voicemail for the user so that the call will be forwarded to the user's voicemail if there is no answer or the call is rejected. The default setting is "Yes".
Voicemail Password	Configure voicemail password (digits only) for the user to access the voicemail box. A random numeric password is automatically generated when the extension is created. It is recommended to use the random generated password for security purpose.
Call Forward Unconditional	Configure the Call Forward Unconditional target number so that the incoming call to this extension will be always forwarded to the target number. If not configured, the Call Forward Unconditional feature is deactivated. The default setting is deactivated.
Call Forward No Answer	Configure the Call Forward No Answer target number so that the incoming call to this extension will be forwarded to the target number if the call is not answered until the ringing times out. If not configured, the Call Forward No Answer feature is deactivated. The default setting is deactivated.
Call Forward Busy	Configure the Call Forward Busy target number so that the incoming call to this extension will be forwarded to the target number if the call is rejected or the extension is in talking/busy status. If not configured, the Call Forward Busy feature is deactivated. The default setting is deactivated.
Ring Timeout	Configure the number of seconds to ring the user before the call is forwarded to voicemail (voicemail is enabled) or hang up (voicemail is disabled). If not specified, the default ring timeout is 60 seconds on the

	<p>UCM6510, which can be configured in the global ring timeout setting under web GUI->Internal Options: General Preference. The valid range is between 5 seconds and 600 seconds.</p> <p>Note: If the end point also has a ring timeout configured, the actual ring timeout used is the shortest time set by either device.</p>
Auto Record	<p>Enable automatic recording for the calls using this extension. The default setting is disabled. The recording files will be saved in external storage if plugged in and can be accessed under web GUI->CDR->Recording Files.</p>
Skip Voicemail Password Verification	<p>When user dials voicemail code, the password verification IVR is skipped. If enabled, this would allow one-button voicemail access. By default this option is disabled.</p>
User Settings	
First Name	<p>Configure the first name of the user. The first name can contain characters, letters, digits and _.</p>
Last Name	<p>Configure the last name of the user. The last name can contain characters, letters, digits and _.</p>
Email Address	<p>Fill in the Email address for the user. Voicemail will be sent to this Email address.</p>
Language	<p>Select the voice prompt language to be used for this extension. The default setting is "Default" which is the selected voice prompt language under web GUI->PBX->Internal Options->Language. The dropdown list shows all the current available voice prompt languages on the UCM6510. To add more languages in the list, please download voice prompt package by selecting "Check Prompt List" under web GUI->PBX->Internal Options->Language.</p>
Analog Settings	
Call Waiting	<p>Configure to enable/disable call waiting feature for the FXS extension. When enabled, the FXS extension currently in an active call allows a new call to come in and can hear call waiting tone on the new incoming call. The default setting is "No".</p>
User # as SEND	<p>If configured, the # key can be used as SEND key after dialing the number on the analog phone. The default setting is "Yes".</p>
RX Gain	<p>Configure the RX gain for the receiving channel of analog FXS port. The valid range is -30dB to +6dB. The default setting is 0.</p>
TX Gain	<p>Configure the TX gain for the transmitting channel of analog FXS port.</p>

	The valid range is -30dB to +6dB. The default setting is 0.
MIN RX Flash	Configure the minimum period of time (in milliseconds) that the hook-flash must remain unpressed for the PBX to consider the event as a valid flash event. The valid range is 30ms to 1000ms. The default setting is 200ms.
MAX RX Flash	Configure the maximum period of time (in milliseconds) that the hook-flash must remain unpressed for the PBX to consider the event as a valid flash event. The minimum period of time is 256ms and it can't be modified. The default setting is 1250ms.
Enable Polarity Reversal	If enabled, a polarity reversal will be marked as received when an outgoing call is answered by the remote party. For some countries, a polarity reversal is used for signaling the disconnection of a phone line and the call will be considered as hangup on a polarity reversal. The default setting is "Yes".
Echo Cancellation	Specify "ON", "OFF" or a value (the power of 2) from 32 to 1024 as the number of taps of cancellation. Note: When configuring the number of taps, the number 256 is not translated into 256ms of echo cancellation. Instead, 256 taps means $256/8 = 32$ ms. The default setting is "ON", which is 128 taps.
3-Way Calling	Configure to enable/disable 3-way calling feature on the user. The default setting is enabled. For example, when enabled, if the FXS extension has established a call with User A -> Press "Flash" to open a new line -> FXS extension calls User B -> Press flash again, it will establish 3-way conference call with User A and User B.
Send CallerID After	Configure the number of rings before sending CID. The default setting is 1.
Other Settings	
Fax Detection	Enable to detect Fax signal from the user/trunk during the call and send the received Fax to the Email address configured for this extension. If no Email address can be found for the user, send the received Fax to the default Email address in Fax setting page under web GUI->PBX->Internal Options->Fax/T.38. Note: If enabled, Fax Pass-through cannot be used.
Skip Trunk Auth	If enabled, users will not need enter the "PIN Set" required by the outbound rule to make outbound calls. The default setting is "No".

BATCH ADD EXTENSIONS

BATCH ADD SIP EXTENSIONS

Under web GUI->**PBX->Basic/Call Routes->Extensions**, click on "Batch Add Extensions"->"Batch Add SIP Extensions".

Table 21: Batch Add SIP Extension Parameters

General	
Start Extension	Configure the starting extension number of the batch of extensions to be added.
Create Number	Specify the number of extensions to be added. The default setting is 5.
Permission	<p>Assign permission level to the user. The available permissions are "Internal", "Local", "National" and "International" from the lowest level to the highest level. The default setting is "Internal".</p> <p>Note: Users need to have the same level as or higher level than an outbound rule's privilege in order to make outbound calls using this rule. If the outbound rule privilege is disabled, this option will not take effect.</p>
Enable Voicemail	Enable Voicemail for the user. The default setting is "Yes".
SIP/IAX Password	<p>Configure the SIP/IAX password for the users. Three options are available to create password for the batch of extensions.</p> <ul style="list-style-type: none"> User Random Password. A random secure password will be automatically generated. It is recommended to use this password for security purpose. Enter a password to be used on all the extensions in the batch.
Voicemail Password	<p>Configure Voicemail password (digits only) for the users.</p> <ul style="list-style-type: none"> User Random Password. A random password in digits will be automatically generated. It is recommended to use this password for security purpose. Enter a password to be used on all the extensions in the batch.
Ring Timeout	Configure the number of seconds to ring the user before the call is forwarded to voicemail (voicemail is enabled) or hang up (voicemail is disabled). If not specified, the default ring timeout is 60 seconds on the UCM6510, which can be configured in the global ring timeout setting under web GUI-> Internal Options : General Preference. The valid range is between 5 seconds and 600 seconds.

	<p>Note:</p> <p>If the end point also has a ring timeout configured, the actual ring timeout used is the shortest time set by either device.</p>
Auto Record	<p>Enable automatic recording for the calls using this extension. The default setting is disabled. The recording files will be saved in external storage if plugged in and can be accessed under web GUI->CDR->Recording Files.</p>
Skip Voicemail Password Verification	<p>When user dials voicemail code, the password verification IVR is skipped. If enabled, this would allow one-button voicemail access. By default this option is disabled.</p>
SIP Settings	
NAT	<p>Use NAT when the PBX is on a public IP communicating with devices hidden behind NAT (e.g., broadband router). If there is one-way audio issue, usually it's related to NAT configuration or Firewall's support of SIP and RTP ports. The default setting is enabled.</p>
Can Reinvite	<p>By default, the PBX will route the media streams from SIP endpoints through itself. If enabled, the PBX will attempt to negotiate with the endpoints to route the media stream directly. It is not always possible for the PBX to negotiate endpoint-to-endpoint media routing. The default setting is "No".</p>
DTMF Mode	<p>Select DTMF mode for the user to send DTMF. The default setting is "RFC2833". If "Info" is selected, SIP INFO message will be used. If "Inband" is selected, 64-kbit codec PCMU and PCMA are required. When "Auto" is selected, RFC2833 will be used if offered, otherwise "Inband" will be used.</p>
Insecure	<ul style="list-style-type: none"> • Port: Allow peers matching by IP address without matching port number. • Very: Allow peers matching by IP address without matching port number. Also, authentication of incoming INVITE messages is not required. • No: Normal IP-based peers matching and authentication of incoming INVITE. <p>The default setting is "Port".</p>
Enable Keep-alive	<p>If enabled, empty SDP packet will be sent to the SIP server periodically to keep the NAT port open. The default setting is "Yes".</p>
Keep-alive Frequency	<p>Configure the number of seconds for the host to be up for Keep-alive. The default setting is 60 seconds.</p>
Other Settings	

S RTP	Enable SRTP for the call. The default setting is "No".
Fax Detection	<p>Enable to detect Fax signal from the user/trunk during the call and send the received Fax to the Email address configured for this extension. If no Email address can be found for the user, send the received Fax to the default Email address in Fax setting page under web GUI->PBX->Internal Options->Fax/T.38.</p> <p>Note: If enabled, Fax Pass-through cannot be used.</p>
Strategy	<p>This option controls how the extension can be used on devices within different types of network.</p> <ul style="list-style-type: none"> • Allow All Device in any network can register this extension. • Local Subnet Only Only the user in specific subnet can register this extension. Up to three subnet addresses can be specified. • A Specific IP Address. Only the device on the specific IP address can register this extension. <p>The default setting is "Allow All".</p>
Skip Trunk Auth	If enabled, users will not need enter the "PIN Set" required by the outbound rule to make outbound calls. The default setting is "No".
Codec Preference	Select audio and video codec for the extension. The available codecs are: PCMU, PCMA, GSM, AAL2-G.726-32, G.722, G.729, G.723, ILBC, ADPCM, LPC10, H.264, H.263 and H.263p. In the selected codec list, users can click on UP or DOWN arrow to adjust the order for the codec priority.

BATCH ADD IAX EXTENSIONS

Under web GUI->PBX->Basic/Call Routes->Extensions, click on "Batch Add Extensions"->"Batch Add IAX Extensions".

Table 22: Batch Add IAX Extension Parameters



General	
Start Extension	Configure the starting extension number of the batch of extensions to be added.

Create Number	Specify the number of extensions to be added. The default setting is 5.
Permission	<p>Assign permission level to the user. The available permissions are "Internal", "Local", "National" and "International" from the lowest level to the highest level. The default setting is "Internal".</p> <p>Note: Users need to have the same level as or higher level than an outbound rule's privilege in order to make outbound calls using this rule. If the outbound rule privilege is disabled, this option will not take effect.</p>
Enable Voicemail	Enable Voicemail for the user. The default setting is "Yes".
SIP/IAX Password	<p>Configure the SIP/IAX password for the users. Three options are available to create password for the batch of extensions.</p> <ul style="list-style-type: none"> User Random Password. A random secure password will be automatically generated. It is recommended to use this password for security purpose. Enter a password to be used on all the extensions in the batch.
Voicemail Password	<p>Configure Voicemail password (digits only) for the users.</p> <ul style="list-style-type: none"> User Random Password. A random password in digits will be automatically generated. It is recommended to use this password for security purpose. Enter a password to be used on all the extensions in the batch.
Ring Timeout	<p>Configure the number of seconds to ring the user before the call is forwarded to voicemail (voicemail is enabled) or hang up (voicemail is disabled). If not specified, the default ring timeout is 60 seconds on the UCM6510, which can be configured in the global ring timeout setting under web GUI->Internal Options: General Preference. The valid range is between 5 seconds and 600 seconds.</p> <p>Note: If the end point also has a ring timeout configured, the actual ring timeout used is the shortest time set by either device.</p>
Auto Record	Enable automatic recording for the calls using this extension. The default setting is disabled. The recording files will be saved in external storage if plugged in and can be accessed under web GUI-> CDR -> Recording Files .
Skip Voicemail Password Verification	When user dials voicemail code, the password verification IVR is skipped. If enabled, this would allow one-button voicemail access. By default this option is disabled.

IAX Settings





Max Number of Calls	Configure the maximum number of calls allowed for each remote IP address.
Require Call Token	Configure to enable/disable requiring call token. If set to "Auto", it might lock out users who depend on backward compatibility when peer authentication credentials are shared between physical endpoints. The default setting is "Yes".
Other Settings	
SRTP	Enable SRTP for the call. The default setting is "No".
Fax Detection	<p>Enable to detect Fax signal from the user/trunk during the call and send the received Fax to the Email address configured for this extension. If no Email address can be found for the user, send the received Fax to the default Email address in Fax setting page under web GUI->PBX->Internal Options->Fax/T.38.</p> <p>Note: If enabled, Fax Pass-through cannot be used.</p>
Strategy	<p>This option controls how the extension can be used on devices within different types of network.</p> <ul style="list-style-type: none"> • Allow All Device in any network can register this extension. • Local Subnet Only Only the user in specific subnet can register this extension. Up to three subnet addresses can be specified. • A Specific IP Address. Only the device on the specific IP address can register this extension. <p>The default setting is "Allow All".</p>
Skip Trunk Auth	If enabled, users will not need enter the "PIN Set" required by the outbound rule to make outbound calls. The default setting is "No".
Codec Preference	Select audio and video codec for the extension. The available codecs are: PCMU, PCMA, GSM, AAL2-G.726-32, G.722, G.729, G.723, ILBC, ADPCM, LPC10, H.264, H.263 and H.263p. In the selected codec list, users can click on UP or DOWN arrow to adjust the order for the codec priority.

EDIT EXTENSION

All the UCM6510 extensions are listed under web GUI->**PBX->Basic/Call Routes->Extensions**, with status, Extension, CallerID Name, Technology (SIP, IAX and FXS), IP and Port. Each extension has a checkbox for users to "Modify Selected Extensions" or "Delete Selected Extensions". Also, options "Edit" , "Reboot"  and "Delete"  are available per extension.

- **Status**

Users can see the following icon for each extension to indicate the SIP status.

	Green:	Free
	Blue:	Ringing
	Yellow:	In Use
	Grey:	Unavailable

- **Edit single extension**

Click on  to start editing the extension parameters.

- **Reboot the user**

Click on  to send NOTIFY reboot event to the device which has an UCM6510 extension already registered. To successfully reboot the user, "Zero Config" needs to be enabled on the UCM6510 web GUI->**PBX->Basic/Call Routes->Zero Config->Auto Provisioning Settings**.

- **Delete single extension**

Click on  to delete the extension. Or select the checkbox of the extension and then click on "Delete Selected Extensions".

- **Modify selected extensions**

Select the checkbox for the extension(s). Then click on "Modify Selected Extensions" to edit the extensions in a batch.

- **Delete selected extensions**

Select the checkbox for the extension(s). Then click on "Delete Selected Extensions" to delete the extension(s).

EXPORT EXTENSIONS

The extensions configured on the UCM6510 can be exported to csv format file with selected technology "SIP", "IAX" or "FXS". Click on "Export Extensions" button and select technology in the prompt.

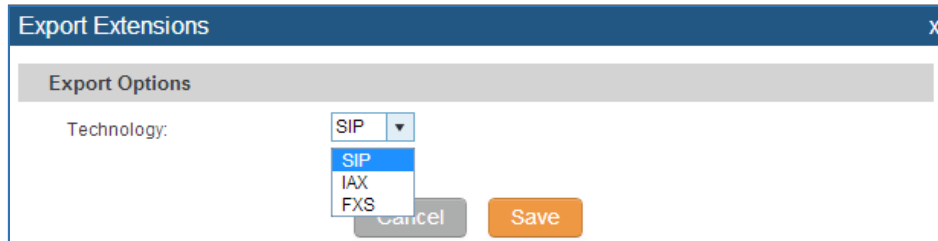

Figure 33: Export Extensions

The exported csv file can also serve as a template for users to fill in desired extension information to be imported to the UCM6510.

IMPORT EXTENSIONS

The capability to import extensions to the UCM6510 provides users flexibility to batch add extensions with similar or different configurations quickly.

1. Export extension csv file from the UCM6510 by clicking on "Export Extensions" button.
2. Fill up the extension information you would like in the exported csv template.
3. Click on "Import Extensions" button. The following dialog will be prompted.

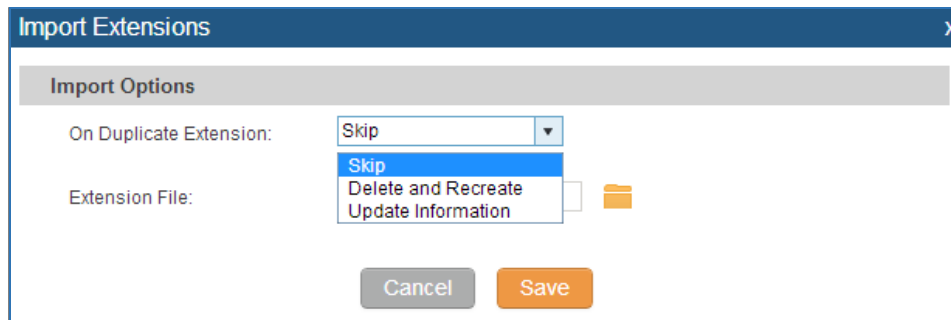



Figure 34: Export Extensions

4. Select the option in "On Duplicate Extension" to define how the duplicate extension(s) in the imported csv file should be treated by the PBX.

- Skip: Duplicate extensions in the csv file will be skipped. The PBX will keep the current extension information as previously configured without change.
 - Delete and Recreate: The current extension previously configured will be deleted and the duplicate extension in the csv file will be loaded to the PBX.
 - Update Information: The current extension previously configured in the PBX will be kept. However, if the duplicate extension in the csv file has different configuration for any options, it will override the configuration for those options in the extension.
5. Click on  to select csv file from local directory in the PC for uploading.
 6. Click on "Save" to import the csv file.
 7. Click on "Apply Changes" to apply the imported file on the UCM6510.

EMAIL TO USER

Once the extensions are created with Email address, the PBX administrator can click on button “Email To User” to send the account registration and configuration information to the user. Please make sure Email setting under web UI->**Settings->Email Settings** is properly configured and tested on the UCM6510 before using “Email To User”.

When click on “Email To User” button, the following message will be prompted in the web page. Click on OK to confirm sending the account information to all users’ Email addresses.

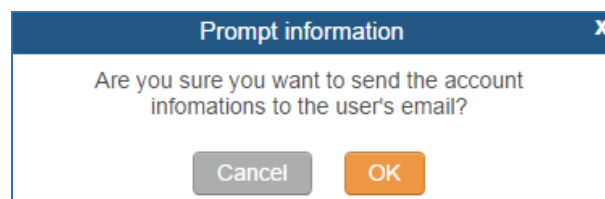

Figure 35: Email To User: Prompt Information

The user will receive Email including account registration information and LDAP configuration. A QR code is also generated for Mobile applications to scan it and get automatically provisioned. QR code provisioning is supported on Grandstream Softphone GS Wave Android™ application.

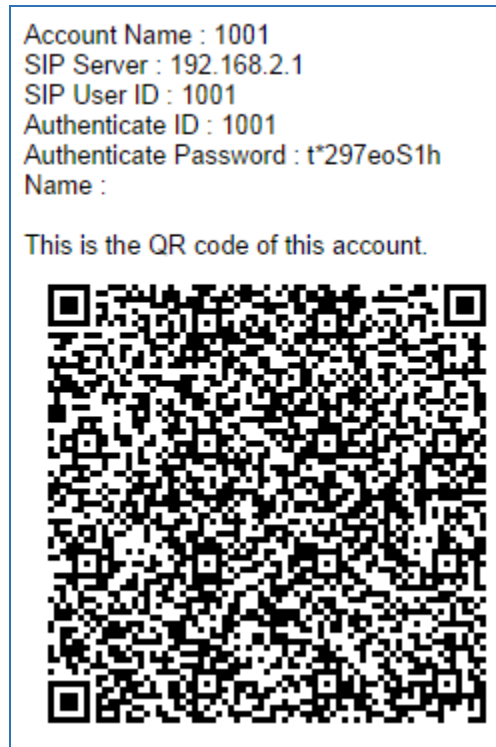

Figure 36: Email To User: Account Registration Information and QR Code



Figure 37: Email To User: LDAP Client Information and QR Code

This page intentionally left blank



ANALOG TRUNKS

To set up analog trunk on the UCM6510:

- Go to web GUI->**PBX->Basic/Call Routes->Analog Trunks** to add and edit analog trunks.
- Go to web GUI->**PBX->Ports Config->Analog Hardware** to configure analog hardware settings.

ANALOG TRUNKS CONFIGURATION

Go to web GUI->**PBX->Basic/Call Routes->Analog Trunks** to add and edit analog trunks.

- Click on "Create New Analog Trunk" to add a new analog trunk.
- Click on  to edit the analog trunk.
- Click on  to delete the analog trunk.

The analog trunk options are listed in the table below.

Table 23: Analog Trunk Configuration Parameters

Channels	Select the channel for the analog trunk.
Trunk Name	Specify a unique label to identify the trunk when listed in outbound routes, inbound routes and etc.
Advanced Options	
Enable Polarity Reversal	If enabled, a polarity reversal will be marked as received when an outgoing call is answered by the remote party. For some countries, a polarity reversal is used for signaling the disconnection of a phone line and the call will be considered as "hangup" on a polarity reversal. The default setting is "No".
Polarity on Answer Delay	When FXO port answers the call, FXS may send a Polarity Reversal. If this interval is shorter than the value of "Polarity on Answer Delay", the Polarity Reversal will be ignored. Otherwise, the FXO will onhook to disconnect the call. The default setting is 600ms.
Current Disconnect Threshold (ms)	This is the periodic time (in ms) that the UCM6510 will use to check on a voltage drop in the line. The default setting is 200. The valid range is 50 to 3000.

Ring Timeout	Configure the ring timeout (in ms). Trunk (FXO) devices must have a timeout to determine if there was a hangup before the line is answered. This value can be used to configure how long it takes before the UCM6510 considers a non-ringing line with hangup activity. The default setting is 8000.
RX Gain	Configure the RX gain for the receiving channel of analog FXO port. The valid range is from -13.5 (dB) to + 12.0 (dB). The default setting is 0.
TX Gain	Configure the TX gain for the transmitting channel of analog FXO port. The valid range is from -13.5 (dB) to + 12.0 (dB). The default setting is 0.
Use CallerID	Configure to enable CallerID detection. The default setting is "Yes".
Fax Detection	Enable to detect Fax signal from the trunk during the call and send the received Fax to the default Email address in Fax setting page under web GUI->PBX->Internal Options->Fax/T.38. The default setting is "No". Note: If enabled, Fax Pass-through cannot be used.
Caller ID Scheme	Select the Caller ID scheme for this trunk. If you are not sure which scheme to choose, please select "Auto Detect". The default setting is "Bellcore/Telcordia".
Auto Record	Enable automatic recording for the calls using this trunk. The default setting is disabled. The recording files are saved in external storage device if plugged in and can be accessed under web GUI-> CDR->Recording Files .
Tone Settings	
Busy Detection	Busy Detection is used to detect far end hangup or for detecting busy signal. The default setting is "Yes".
Busy Tone Count	If "Busy Detection" is enabled, users can specify the number of busy tones to be played before hanging up. The default setting is 2. Better results might be achieved if set to 4, 6 or even 8. Please note that the higher the number is, the more time is needed to hangup the channel. However, this might lower the probability to get random hangup.
Congestion Detection	Congestion detection is used to detect far end congestion signal. The default setting is "Yes".
Congestion Count	If "Congestion Detection" is enabled, users can specify the number of congestion tones to wait for. The default setting is 2.
Tone Country	Select the country for tone settings. If "Custom" is selected, users could manually configure the values for Busy Tone and Congestion Tone. The default setting is "United States of America (USA)".

<p>Busy Tone</p>	<p>Syntax: f1=val[@level][,f2=val[@level]],c=on1/off1[-on2/off2[-on3/off3]]; Frequencies are in Hz and cadence on and off are in ms. Frequencies Range: [0, 4000) Busy Level Range: (-300, 0) Cadence Range: [0, 16383]. Select Tone Country "Custom" to manually configure Busy Tone value.</p> <p>Default value: f1=480@-50,f2=620@-50,c=500/500</p>
<p>Congestion Tone</p>	<p>Syntax: f1=val[@level][,f2=val[@level]],c=on1/off1[-on2/off2[-on3/off3]]; Frequencies are in Hz and cadence on and off are in ms. Frequencies Range: [0, 4000) Busy Level Range: (-300, 0) Cadence Range: [0, 16383]. Select Tone Country "Custom" to manually configure Busy Tone value.</p> <p>Default value: f1=480@-50,f2=620@-50,c=250/250</p>
<p>PSTN Detection</p>	<p>Click on "Detect" to detect the busy tone, Polarity Reversal and Current Disconnect by PSTN. Before the detecting, please make sure there are more than one channel configured and working properly. If the detection has busy tone, the "Tone Country" option will be set as "Custom".</p>

PSTN DETECTION

The UCM6510 provides PSTN detection function to help users detect the busy tone, Polarity Reversal and Current Disconnect by making a call from the PSTN line to another destination. The detecting call will be answered and up for about 1 minute. Once done, the detecting result will show and can be used for the UCM6510 settings.

1. Go to UCM6510 web GUI->**PBX->Basic/Call Routes->Analog Trunks** page.
2. Click to edit the analog trunk created for the FXO port.
3. In the dialog window to edit the analog trunk, go to "Tone Settings" section and click on  for "PSTN Detection".

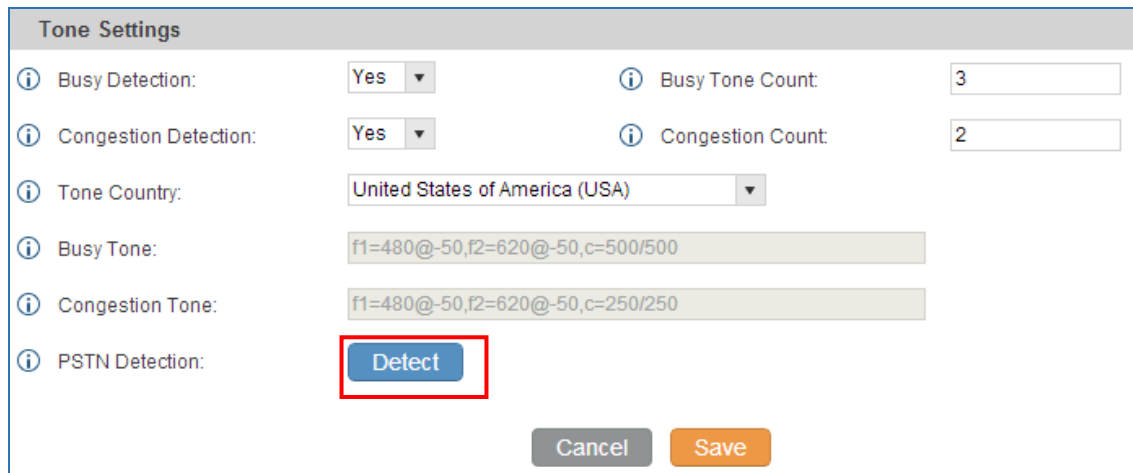

Figure 38: UCM6510 FXO Tone Settings

4. Click on "Detect" to start PSTN detection.

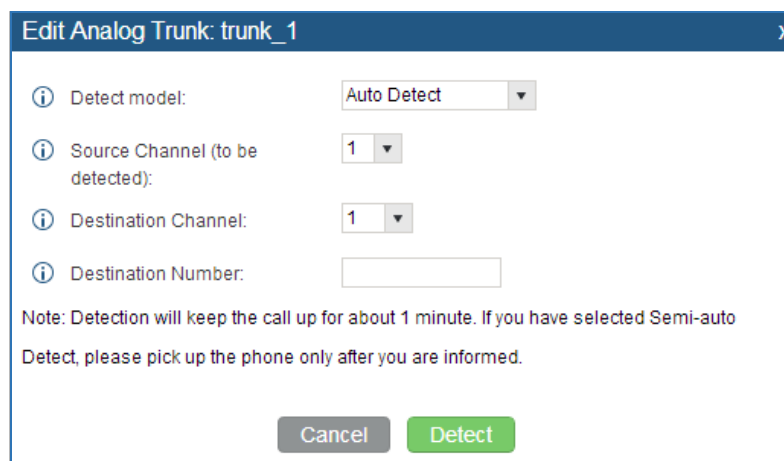

Figure 39: UCM6510 PSTN Detection

- If there are two FXO ports connected to PSTN lines, use the following settings for auto-detection.

Detect Model: Auto Detect.

Source Channel: The source channel to be detected.

Destination Channel: The channel to help detecting. For example, the second FXO port.

Destination Number: The number to be dialed for detecting. This number must be the actual PSTN number for the FXO port used as the destination channel.



Edit Analog Trunk: trunk_1

Detect model:

Source Channel (to be detected):

Destination Channel:

Destination Number:

Note: Detection will keep the call up for about 1 minute. If you have selected Semi-auto Detect, please pick up the phone only after you are informed.

Figure 40: UCM6510 PSTN Detection: Auto Detect

- If there is only one FXO port connected to PSTN line, use the following settings for auto-detection.

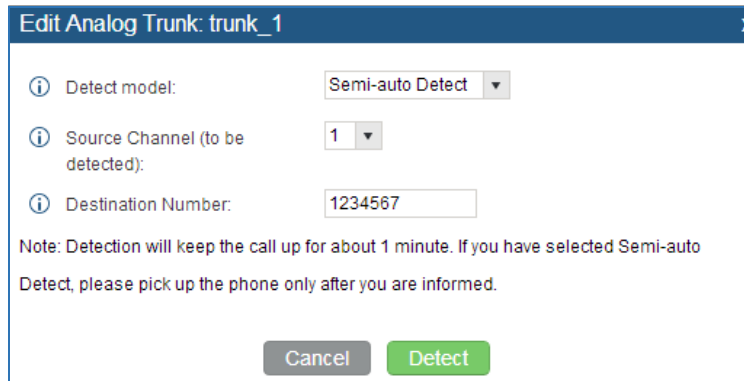

Edit Analog Trunk: trunk_1

Detect model:

Source Channel (to be detected):

Destination Number:

Note: Detection will keep the call up for about 1 minute. If you have selected Semi-auto Detect, please pick up the phone only after you are informed.

Figure 41: UCM6510 PSTN Detection: Semi-Auto Detect

Detect Model: Semi-auto Detect.

Source Channel: The source channel to be detected.

Destination Number: The number to be dialed for detecting. This number could be a cell phone number or other PSTN number that can be reached from the source channel PSTN number.

5. Click "Detect" to start detecting. The source channel will initiate a call to the destination number. For "Auto Detect", the call will be automatically answered. For "Semi-auto Detect", the UCM6510 web GUI will display prompt to notify the user to answer or hang up the call to finish the detecting process.
6. Once done, the detected result will show. Users could save the detecting result as the current UCM6510 settings.

Table 24: PSTN Detection for Analog Trunk

Detect Model	<p>Select "Auto Detect" or "Semi-auto Detect" for PSTN detection.</p> <ul style="list-style-type: none"> • Auto Detect Please make sure two or more channels are connected to the UCM6510 and in idle status before starting the detection. During the detection, one channel will be used as caller (Source Channel) and another channel will be used as callee (Destination Channel). The UCM6510 will control the call to be established and hang up between caller and callee to finish the detection. • Semi-auto Detect Semi-auto detection requires answering or hanging up the call manually. Please make sure one channel is connected to the UCM6510 and in idle status before starting the detection. During the detection, source channel will be used as caller and send the call to the configured Destination Number. Users will then need follow the prompts in web GUI to help finish the detection. <p>The default setting is "Auto Detect".</p>
Source Channel	Select the channel to be detected.
Destination Channel	Select the channel to help detect when "Auto Detect" is used.
Destination Number	Configure the number to be called to help the detection.



Note:

- The PSTN detection process will keep the call up for about 1 minute.
- If "Semi-auto Detect" is used, please pick up the call only after informed from the web GUI prompt.
- Once the detection is successful, the detected parameters "Busy Tone", "Polarity Reversal" and "Current Disconnect by PSTN" will be filled into the corresponding fields in the analog trunk configuration.

ANALOG HARDWARE CONFIGURATION

The analog hardware (FXS port and FXO port) on the UCM6510 can be configured under web GUI- >**PBX->Ports Config->Analog Hardware**. Click on  to edit signaling preference for FXS port or configure ACIM settings for FXO port.

Select "Loop Start" or "Kewl Start" for each FXS port. And then click on "Update" to save the change.

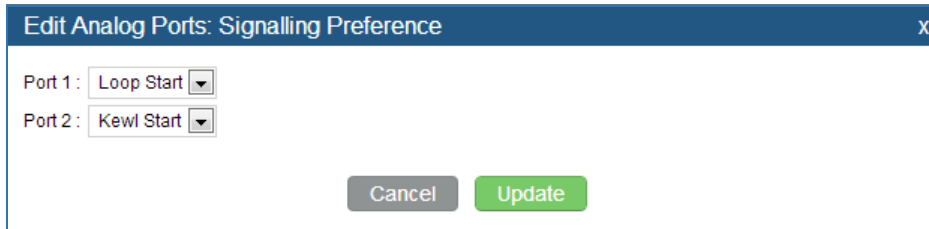

Figure 42: FXS Ports Signaling Preference

For FXO port, users could manually enter the ACIM settings by selecting the value from dropdown list for each port. Or users could click on "Detect" for the UCM6510 to automatically detect the ACIM value. The detecting value will be automatically filled into the settings.

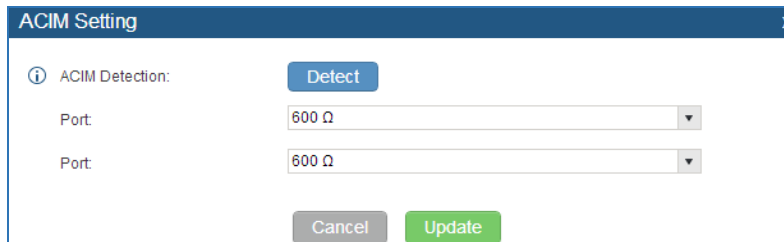

Figure 43: FXO Ports ACIM Settings

 **Note:**

ACIM setting is very important for the FXO/PSTN line to work properly on the UCM6510. If the users experience echo, caller ID or disconnecting issue, please make sure to run the ACIM detection to find out the correct value for impedance setting.

Table 25: Analog Hardware Configuration Parameters

Tone Region	Select country to set the default tones for dial tone, busy tone, ring tone and etc to be sent from the FXS port. The default setting is "United States of America (USA)".
Advanced Settings	
FXO Opermode	Select country to set the On Hook Speed, Ringer Impedance, Ringer Threshold, Current Limiting, TIP/RING voltage adjustment, Minimum Operational Loop Current, and AC Impedance as predefined for your country's analog line characteristics. The default setting is "United States of America (USA)".
FXS Opermode	Select country to set the On Hook Speed, Ringer Impedance, Ringer Threshold, Current Limiting, TIP/RING voltage adjustment, Minimum Operational Loop Current, and AC Impedance as predefined for your country's analog line characteristics. The default setting is "United States of America (USA)".
FXS TISS Override	Configure to enable or disable override Two-Wire Impedance Synthesis (TISS). The default setting is No. If enabled, users can select the impedance value for Two-Wire Impedance Synthesis (TISS) override. The default setting is 600Ω.
PCMA Override	Select the codec to be used for analog lines. North American users should choose PCMU. All other countries, unless already known, should be assumed to be PCMA. The default setting is PCMU. Note: This option requires system reboot to take effect.
Boost Ringer	Configure whether normal ringing voltage (40V) or maximum ringing voltage (89V) for analog phones attached to the FXS port is required. The default setting is "Normal".
Fast Ringer	Configure to increase the ringing speed to 25HZ. This option can be used with "Low Power" option. The default setting is "Normal".
Low Power	Configure the peak voltage up to 50V during "Fast Ringer" operation. This option is used with "Fast Ringer". The default setting is "Normal".
Ring Detect	If set to "Full Wave", false ring detection will be prevented for lines where Caller ID is sent before the first ring and proceeded by a polarity reversal, as in UK. The default setting is "Standard".
FXS MWI Mode	Configure the type of Message Waiting Indicator on FXS lines. The default setting is "FSK". <ul style="list-style-type: none"> • FSK: Frequency Shift Key Indicator • NEON: Light Neon Bulb Indicator.

DIGITAL TRUNKS

The UCM6510 supports E1/T1/J1 which are physical connection technology used in digital network. T1 is the North American standard, J1 is used in Japan, whereas E1 is the European standard.

UCM6510 supports three signaling protocols: PRI, MFC/R2 and SS7. PRI provides a varying number of channels depending on the standards in the country of implementation (E1, T1 or J1); MFC/R2 is a signaling protocol heavily used over E1 trunks; SS7 uses out-of-band signaling, which travels on a separate, dedicated channel rather than within the same channel as the telephone call, providing more efficiency and higher security level when the telephone calls are set up.

To set up digital trunk on the UCM6510:

1. Go to web UI->**PBX->Ports Config->Digital Hardware** to configure port type and channels.
2. Go to web UI->**PBX->Basic/Call Routes->Digital Trunks** to add and edit digit trunk.
3. Go to web UI->**PBX->Basic/Call Routes->Outbound Routes** and **Inbound Routes** to configure outbound and inbound rule for the digital trunk.

DIGITAL HARDWARE CONFIGURATION

Go to web GUI->**PBX->Ports Config->Digital Hardware** page and configure the following:

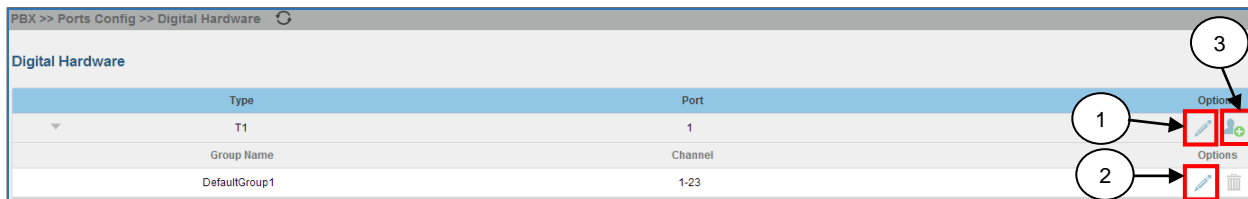





Figure 44: Digital Hardware Configuration

- **Step 1:** Click on  to edit digital ports. Please see configuration parameters in the tables below.
- **Step 2:** Click on  to edit group. This assigns channels to be used for the digital port. For E1, 30 B channels can be assigned to the default group; for T1/J1, 23 B channels can be assigned to the default group.
- **Step 3:** If fewer than 30 B channels for E1 or 23 B channels for T1/J1 are assigned in default group, users can click on  to add more groups. This is not necessary in most cases and only default

group is needed.

 **Note:**

Currently, the group configuration in digit trunks settings is to manage outbound routes only. It doesn't control inbound routes. Therefore, if the users have configured multiple groups for the digital trunk, please make sure the inbound routes for those groups have the same inbound rule configured. Otherwise, inbound call using the digital trunk might not work properly.

The UCM6510 currently supports E1, T1 and J1 digital hardware type. When different signaling is selected for E1, T1 or J1, the settings in basic options and advanced options will be different. The following tables list all the settings to configure digital ports when selecting each signaling.

Table 26: Digital Hardware Configuration Parameters: E1 - PRI_NET/PRI_CPE

Basic Settings	
Clock	<p>All E1/T1/J1 spans generate a clock signal on their transmit side. The parameter determines whether the clock signal from the far end of the E1/T1/J1 is used as the master source of clock timing. If the far end is used as the master, the PBX system clock will synchronize to it.</p> <ul style="list-style-type: none"> • Master: The port will never be used as a source of timing. This is appropriate when you know the far end should always be a slave to you. • Slave: The equipment at the far end of the E1/T1/J1 link is the preferred source of the master clock.
LBO	The line build-out (LBO) is the distance between the operators and the PBX. Please use the default value 0dB unless the distance is long.
RX Gain	Configure the RX gain for the receiving channel of digital port. The valid range is from -24dB to +12dB.
TX Gain	Configure the TX Gain for the transmitting channel of digital port. The valid range is -24dB to +12dB.
Codec	Select alaw or ulaw. If set to default, alaw will be used for E1.
Play Local RBT	This configured whether to play the ringback tone from local UCM6510 or

	not. If enabled, the local UCM6510 will play ringback tone to the caller. Otherwise, the caller will listen to the tone from peer device. The default setting is disabled.
Advanced Settings	
Switch Type	<p>Select switch type.</p> <ul style="list-style-type: none"> • EuroISDN: EuroISDN (common in Europe) • NI2: National ISDN type 2 (common in the US) • DMS100: Nortel DMS100 • 4ESS: AT&T 4ESS • 5ESS: Lucent 5ESS • NI1: old national ISDN type 1 • Q.SIG
Coding	Select "HDB3" or "AMI".
CRC	Select whether to use CRC4 or not.
PRI Dial Plan	<p>This setting is used to specify the type of the callee number. The service provider will usually verify this. The default setting is "unknown". In some very unusual circumstances, you may need set to "Dynamic" or "Redundant".</p> <p>Note: When one type is selected, you might not be able to dial another class of numbers. For example, if "National" is configured, you won't be able to dial local or international numbers.</p>
PRI Local Dial Plan	This setting is used to specify the type of the caller number. The service provider will usually verify this.
International Prefix National Prefix Local Prefix Private Prefix Unknown Prefix	Configure the prefix in PRI Local Dial Plan and PRI Dial Plan for each type.
PRI Indication	<p>Select the PRI Indication.</p> <ul style="list-style-type: none"> • outofband: Use RELEASE, DISCONNECT or other messages with CAUSE to indicate call progress (e.g., cause: unassigned number or user busy). • inband: use in-band tones to play busy or congestion signal to the other side. This is the default setting.
Reset Interval	The interval that restarts idle channels.
PRI Exclusive	This setting is used to set up the ChannelID in SETUP message. If enabled, only the specified B channel can be used. Otherwise, select one

	of the channels in B channel. If you need override the existing channels selection routine and force all PRI channels to be marked as exclusively selected, please enable it.
Facility Enable	If selected, transmission of facility-based ISDN supplementary services (such as caller name from CPE over facility) will be enabled.
NSF	Some switches (AT&T especially) require network specific facility. Currently the supported values are "none", "sdn", "megacom", "tollfreemegacom", "accunet".

Table 27: Digital Hardware Configuration Parameters: E1 - SS7

Basic Settings	
Clock	<p>All E1/T1/J1 spans generate a clock signal on their transmit side. The parameter determines whether the clock signal from the far end of the E1/T1/J1 is used as the master source of clock timing. If the far end is used as the master, the PBX system clock will synchronize to it.</p> <ul style="list-style-type: none"> • Master: The port will never be used as a source of timing. This is appropriate when you know the far end should always be a slave to you. • Slave: The equipment at the far end of the E1/T1 link is the preferred source of the master clock.
SS7 Variant	Select ITU, ANSI or CHINA.
Originating Point Code	<p>Originating point code is used to identify the node originating the message, always provided by the operator/ISP.</p> <ul style="list-style-type: none"> • ITU Format: decimal number. • ANSI & CHINA Format: decimal number or XXX-XXX-XXX.
Destination Point Code	<p>Destination point code is the address to send the message to, always be provided by the operator/ISP.</p> <ul style="list-style-type: none"> • ITU Format: decimal number. • ANSI & CHINA Format: decimal number or XXX-XXX-XXX.
Network Indicator	<p>Network Indicator (NI) should match in nodes, otherwise it might cause issues. Users can select "National", "National Spare", "International", or "International Spare". Usually "National" or "International" is used.</p>
LBO	The line build-out (LBO) is the distance between the operators and the PBX. Please use the default value 0dB unless the distance is long.
RX Gain	Configure the RX gain for the receiving channel of digital port. The valid range is from -24dB to +12dB.
TX Gain	Configure the TX Gain for the transmitting channel of digital port. The

	valid range is -24dB to +12dB.
Codec	Select alaw or ulaw. If set to default, alaw will be used for E1.
Advanced Settings	
Coding	Select "HDB3" or "AMI".
CRC	Select whether to use CRC4 or not.
Called Nature of Address Indicator	Indicates the type of the called number. The receiving switch may use this indicator during translations to apply the number's proper dial plan. Users can select "Unknown", "Subscriber", "National", "International" or "Dynamic".
Calling Nature of Address Indicator	Indicates the type of the calling number. The receiving switch may use this indicator during translations to apply the number's proper dial plan. Users can select "Unknown", "Subscriber", "National", "International" or "Dynamic".
International Prefix National Prefix Local Prefix Private Prefix Unknown Prefix	Configure the prefix in PRI Local Dial Plan and PRI Dial Plan for each type.

Table 28: Digital Hardware Configuration Parameters: E1 - MFC/R2

Basic Settings	
Clock	<p>All E1/T1/J1 spans generate a clock signal on their transmit side. The parameter determines whether the clock signal from the far end of the E1/T1/J1 is used as the master source of clock timing. If the far end is used as the master, the PBX system clock will synchronize to it.</p> <ul style="list-style-type: none"> • Master: The port will never be used as a source of timing. This is appropriate when you know the far end should always be a slave to you. • Slave: The equipment at the far end of the E1/T1 link is the preferred source of the master clock.
Variant	MFC/R2 multinational adaption. UCM6510 supports MFC/R2 standards by ITU and MFC/R2 standards in different countries or regions including Argentina, Brazil, China, Czech Republic, Colombia, Ecuador, Indonesia, Mexico, the Philippines and Venezuela.
Get ANI First	If enabled, the callee side will request the caller to send caller number first and then called number.

	Note: Options "Get ANI First" and "Skip Category" cannot be enabled at the same time.
Category	Select the category of the caller. UCM6510 supports four categories: National Subscriber, National Priority Subscriber, International Subscriber and International Priority Subscriber.
LBO	The line build-out (LBO) is the distance between the operators and the PBX. Please use the default value 0dB unless the distance is long.
RX Gain	Configure the RX gain for the receiving channel of digital port. The valid range is from -24dB to +12dB.
TX Gain	Configure the TX Gain for the transmitting channel of digital port. The valid range is -24dB to +12dB.
Play Local RBT	This configured whether to play the ringback tone from local UCM6510 or not. If enabled, the local UCM6510 will play ringback tone to the caller. Otherwise, the caller will listen to the tone from peer device. The default setting is disabled.
Advanced Settings	
Coding	Select "HDB3" or "AMI".
CRC	Select whether to use CRC4 or not.
MF Back Timeout(ms)	MFC/R2 value in milliseconds for MF timeout. Values smaller than 500ms are not recommended. -1 represents default value.
Metering Pulse Timeout(ms)	MFC/R2 value in milliseconds for the metering pulse timeout. Metering pulse is sent by some telcos for some R2 variants during a call presumably for billing purposes to indicate costs. Should not last more than 500ms, -1 represents default value, and for Argentina the default value is 400ms, for others is 0ms.
Allow Collect Calls	Brazil has a special calling party category for collect calls (llamadas por cobrar) instead of using the operator (as in Mexico). The R2 spec in Brazil says a special GB tone should be used to reject collect calls. By default, this is disabled, which means collect calls will be blocked.
Double Answer	Some PBXs require a double-answer process to block collect calls. If users have problem blocking collect calls using Group B signals, please try enabling this option.
Accept On Offer	By default it's enabled. In most of cases, this option should be enabled.
Skip Category	If enabled, the callee side will request the caller to send caller category before sending caller number.

	Note: "Get ANI First" and "Skip Category" cannot be enabled at the same time.
Charge Calls	Whether or not report to the other end "accept call with charge". This setting has no effect with most telecos. The default setting is enabled (recommended).

Table 29: Digital Hardware Configuration Parameters: T1/J1 - PRI_NET/PRI_CPE

Basic Settings	
Clock	<p>All E1/T1/J1 spans generate a clock signal on their transmit side. The parameter determines whether the clock signal from the far end of the E1/T1/J1 is used as the master source of clock timing. If the far end is used as the master, the PBX system clock will synchronize to it.</p> <ul style="list-style-type: none"> • Master: The port will never be used as a source of timing. This is appropriate when you know the far end should always be a slave to you. • Slave: The equipment at the far end of the E1/T1/J1 link is the preferred source of the master clock.
LBO	The line build-out (LBO) is the distance between the operators and the PBX. Please use the default value 0dB unless the distance is long.
RX Gain	Configure the RX gain for the receiving channel of digital port. The valid range is from -24dB to +12dB.
TX Gain	Configure the TX Gain for the transmitting channel of digital port. The valid range is -24dB to +12dB.
Codec	Select alaw or ulaw. If set to default, ulaw will be used for T1/J1.
Play Local RBT	This configured whether to play the ringback tone from local UCM6510 or not. If enabled, the local UCM6510 will play ringback tone to the caller. Otherwise, the caller will listen to the tone from peer device. The default setting is disabled.
Advanced Settings	
Switch Type	<p>Select switch type.</p> <ul style="list-style-type: none"> • EuroISDN: EuroISDN (common in Europe) • NI2: National ISDN type 2 (common in the US) • DMS100: Nortel DMS100 • 4ESS: AT&T 4ESS • 5ESS: Lucent 5ESS • NI1: old national ISDN type 1 • Q.SIG

Coding	Select "B8ZS" or "AMI".
PRI Dial Plan	<p>This setting is used to specify the type of the callee number. The service provider will usually verify this. The default setting is "unknown". In some very unusual circumstances, you may need set to "Dynamic" or "Redundant".</p> <p>Note: When one type is selected, you might not be able to dial another class of numbers. For example, if "National" is configured, you won't be able to dial local or international numbers.</p>
PRI Local Dial Plan	This setting is used to specify the type of the caller number. The service provider will usually verify this.
International Prefix National Prefix Local Prefix Private Prefix Unknown Prefix	Configure the prefix in PRI Local Dial Plan and PRI Dial Plan for each type.
PRI Indication	<p>Select the PRI Indication.</p> <ul style="list-style-type: none"> • outofband: Use RELEASE, DISCONNECT or other messages with CAUSE to indicate call progress (e.g., cause: unassigned number or user busy). • inband: use in-band tones to play busy or congestion signal to the other side. This is the default setting.
Reset Interval	The interval that restarts idle channels.
PRI Exclusive	This setting is used to set up the ChannelID in SETUP message. If enabled, only the specified B channel can be used. Otherwise, select one of the channels in B channel. If you need override the existing channels selection routine and force all PRI channels to be marked as exclusively selected, please enable it.
Facility Enable	If selected, transmission of facility-based ISDN supplementary services (such as caller name from CPE over facility) will be enabled.
NSF	Some switches (AT&T especially) require network specific facility. Currently the supported values are "none", "sdn", "megacom", "tollfreemegacom", "accunet".

Table 30: Digital Hardware Configuration Parameters: T1/J1 - SS7



Basic Settings	
Clock	All E1/T1/J1 spans generate a clock signal on their transmit side. The parameter determines whether the clock signal from the far end of the

	<p>E1/T1/J1 is used as the master source of clock timing. If the far end is used as the master, the PBX system clock will synchronize to it.</p> <ul style="list-style-type: none"> • Master: The port will never be used as a source of timing. This is appropriate when you know the far end should always be a slave to you. • Slave: The equipment at the far end of the E1/T1 link is the preferred source of the master clock.
SS7 Variant	Select ITU, ANSI or CHINA.
Originating Point Code	<p>Originating point code is used to identify the node originating the message, always provided by the operator/ISP.</p> <ul style="list-style-type: none"> • ITU Format: decimal number. • ANSI & CHINA Format: decimal number or XXX-XXX-XXX.
Destination Point Code	<p>Destination point code is the address to send the message to, always be provided by the operator/ISP.</p> <ul style="list-style-type: none"> • ITU Format: decimal number. • ANSI & CHINA Format: decimal number or XXX-XXX-XXX.
Network Indicator	<p>Network Indicator (NI) should match in nodes, otherwise it might cause issues. Users can select "National", "National Spare", "International", or "International Spare". Usually "National" or "International" is used.</p>
LBO	<p>The line build-out (LBO) is the distance between the operators and the PBX. Please use the default value 0dB unless the distance is long.</p>
RX Gain	<p>Configure the RX gain for the receiving channel of digital port. The valid range is from -24dB to +12dB.</p>
TX Gain	<p>Configure the TX Gain for the transmitting channel of digital port. The valid range is -24dB to +12dB.</p>
Codec	Select alaw or ulaw. If set to default, ulaw will be used for T1/J1.
Advanced Settings	
Coding	Select "B8ZS" or "AMI".
Called Nature of Address Indicator	<p>Indicates the type of the called number. The receiving switch may use this indicator during translations to apply the number's proper dial plan. Users can select "Unknown", "Subscriber", "National", "International" or "Dynamic".</p>
Calling Nature of Address Indicator	<p>Indicates the type of the calling number. The receiving switch may use this indicator during translations to apply the number's proper dial plan. Users can select "Unknown", "Subscriber", "National", "International" or "Dynamic".</p>
International Prefix	Configure the prefix in PRI Local Dial Plan and PRI Dial Plan for each

National Prefix	type.
Local Prefix	
Private Prefix	
Unknown Prefix	

DIGITAL TRUNK CONFIGURATION

After configuring digital hardware, go to web GUI->**PBX->Basic/Call Routes->Digital Trunks**.

- Click on "Create New Digital Trunk" to add a new digital trunk.
- Click on  to configure detailed parameters for the digital trunk.
- Click on  to configure Direct Outward Dialing (DOD) for the digital Trunk.
- Click on  to delete the digital trunk.

The digital trunk parameters are listed in the table below.

Table 31: Digital Trunk Configuration Parameters

Trunk Name	Configure trunk name to identify the digital trunk.
Channel Group	Configure the digital channel group used by the trunk.
Hide CallerID	Configure to hide outgoing caller ID. The default setting is "No".
Keep Trunk CID	If enabled, the trunk CID will not be overridden by extension's CID when the extension has CID configured. The default setting is "No".
Caller ID	<p>Configure the Caller ID. This is the number that the trunk will try to use when making outbound calls. For some providers, it might not be possible to set the CallerID with this option and this option will be ignored.</p> <p>When making outgoing calls, the following rules are used to determine which CallerID will be used if they exist:</p> <ul style="list-style-type: none"> • The CallerID configured for the extension will be looked up first. • If "Keep Trunk CID" is enabled, the CallerID configured for the trunk will be used. • If the above two are missing, the "Global Outbound CID" defined in web GUI->PBX->Internal Options->General will be used.

CallerID Name	Configure the new name of the caller when the extension has no CallerID Name configured.
Auto Record	Enable automatic recording for the calls using this trunk (for SIP trunk only). The default setting is disabled. The recording files are saved in external storage device if plugged in and can be accessed under web GUI-> CDR->Recording Files.
Fax Detection	Enable to detect Fax signal from the trunk during the call and send the received Fax to the default Email address in Fax setting page under web GUI->PBX->Internal Options->Fax/T.38. Note: If enabled, Fax Pass-through cannot be used.

DIRECT OUTWARD DIALING (DOD) VIA DIGITAL TRUNKS

Please refer to section **[DIRECT OUTWARD DIALING (DOD) VIA VOIP TRUNKS]**.

DIGITAL TRUNK TROUBLESHOOTING

After configuring the digital trunk on the UCM6510 as described above, if it doesn't work as expected, users can go to capture signaling trace on the UCM6510 web UI for troubleshooting purpose.

Depending on the signaling selected for the digital trunk, users can go to the following pages to capture trace:

PRI Signaling Trace: web GUI->**Maintenance->Troubleshooting ->PRI Signaling Trace**

SS7 Signaling Trace: web GUI->**Maintenance->Troubleshooting ->SS7 Signaling Trace**

MFC/R2 Signaling Trace: web GUI->**Maintenance->Troubleshooting ->MFC/R2 Signaling Trace**

Here is the step to capture trace:

1. Click on "Start" to start capturing trace. The output result shows "Capturing..."
2. Once the test is done, click on "Stop" to stop the trace.
3. Click on "Download" to download the trace.

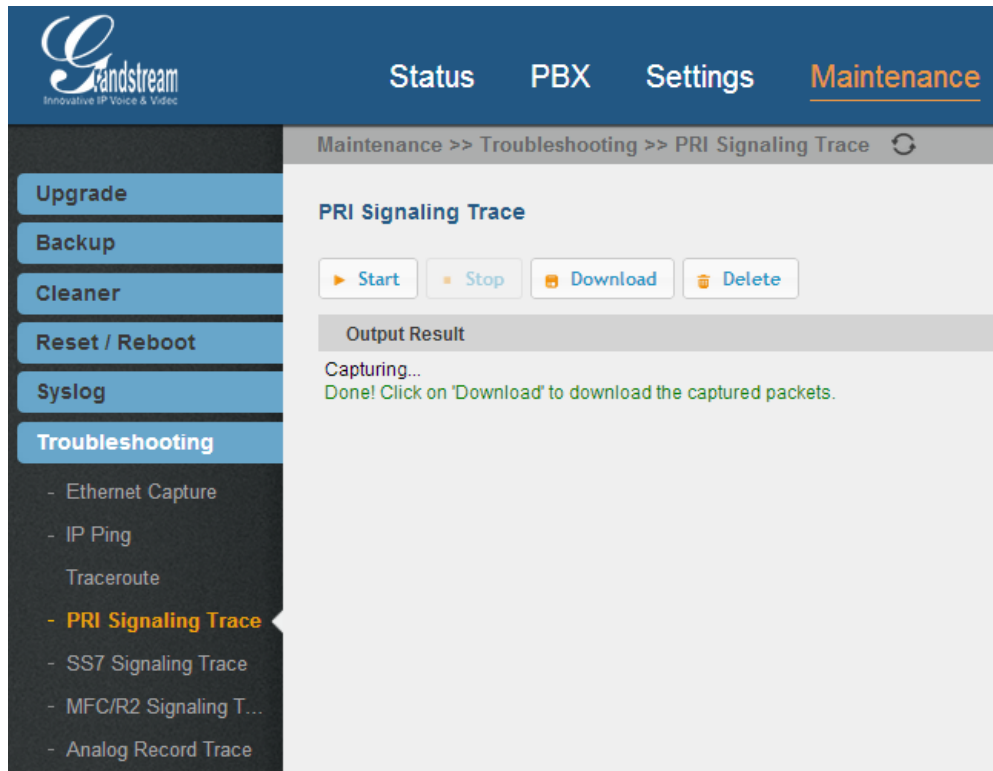

Figure 45: Troubleshooting Digital Trunks







After capturing the trace, users can download it for basic analysis. Or you can contact Grandstream Technical support in the following link for further assistance if the issue is not resolved.

<http://www.grandstream.com/index.php/support>

DATA TRUNK

The UCM6510 E1/T1/J1 interface also supports data trunk function that allows users to access Internet. Users can select HDLC, HDLC-ETH, Cisco and PPP protocol for the data trunk.

To use data trunk,

1. Go to web UI->**PBX->Ports Config->Digital Hardware** page and click  to create a new group. Designate a channel for data trunk usage in the group setting.
2. Go to web UI->**PBX->Basic/Call Routes->Data Trunks** page, click on  to edit the data trunk.
3. Save the configuration and click on “Apply Changes” for the change to take effect.
4. Once connected, the data trunk will periodically ping and check the status, with status indicator shown for the data trunk on the web page. The status indicator shows  if connected successfully.
5. If the user happens to lost connection or experience unstable connection, click on  to reconnect to help resolve the problem.
6. Users can always click on ON/OFF switch   in the web page to enable/disable the configured data trunk.

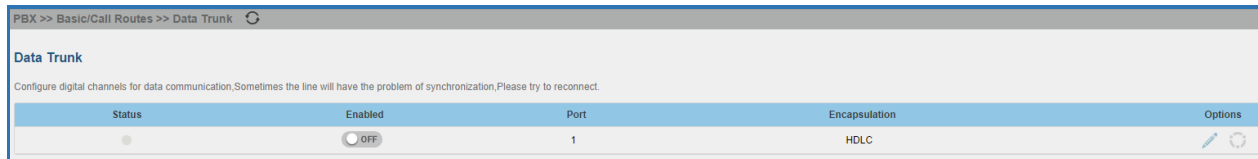

Figure 46: Data Trunk Web Page

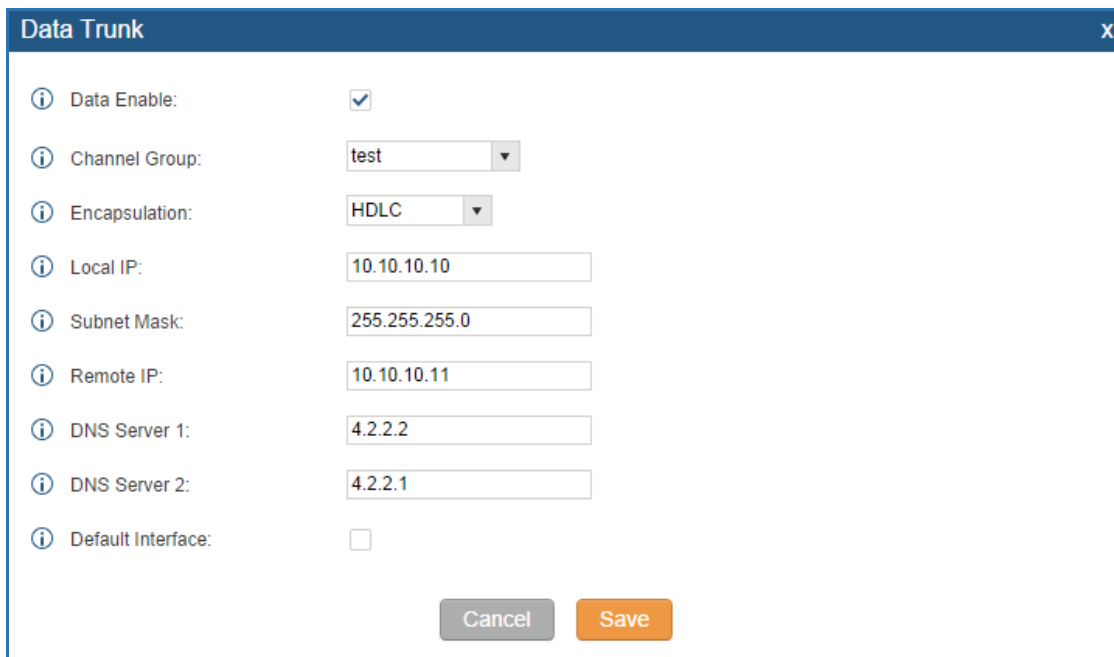

Figure 47: Data Trunk Configuration





Table 32: Data Trunk Configuration Parameters

Data Enable	Select the checkbox to enable/disable data trunk. Users can also click on the ON/OFF switch in data trunk web page to enable/disable this.
Channel Group	Select the digital channel group from the dropdown list to be used for data trunk. Users will need create a new group under web UI-> PBX->Ports Config->Digital Hardware page for this purpose.
Encapsulation	Select the protocol used for the data trunk. The UCM6510 supports HDLC, HDLC-ETH, PPP and Cisco.
Local IP	Configure the local IP address for the data port. This IP address shouldn't conflict with the WAN or LAN side IP of the UCM6510.
Subnet Mask	Configure the subnet mask for the data port.
Remote IP	Configure the remote IP address for the data port. This IP will be the gateway IP address if "Default Interface" is enabled for the datat trunk.
DNS Server 1	Configure DNS server 1.
DNS Server 2	Configure DNS server 2.
Default Interface	If enabled, this data port will be used as the default interface for Internet connection. The "Remote IP" will be the gateway IP address. This has higher priority than the "Default Interface" assignment (LAN 1 or LAN 2) under web UI-> Settings if "Dual" is selected as the network method.

VOIP TRUNKS

VOIP TRUNK CONFIGURATION

VoIP trunks can be configured in UCM6510 under web GUI->**PBX->Basic/Call Routes->VoIP Trunks**. Once created, the VoIP trunks will be listed with Provider Name, Type, Hostname/IP, Username and Options to edit/detect the trunk.

- Click on "Create New SIP Trunk" or "Create New IAX Trunk" to add a new VoIP trunk.
- Click on  to configure detailed parameters for the VoIP trunk.
- Click on  to configure Direct Outward Dialing (DOD) for the SIP Trunk.
- Click on  to start LDAP Sync.
- Click on  to delete the VoIP trunk.

The VoIP trunk options are listed in the table below.

Table 33: SIP Trunk Configuration Parameters

Create New SIP Trunk	
Type	Select the VoIP trunk type. <ul style="list-style-type: none"> • Register SIP Trunk • Peer SIP Trunk
Provider Name	Configure a unique label to identify this trunk when listed in outbound rules, inbound rules and etc.
Host Name	Configure the IP address or URL for the VoIP provider's server of the trunk.
Keep Trunk CID	If enabled, the trunk CID will not be overridden by extension's CID when the extension has CID configured. The default setting is "No".
Username	Enter the username to register to the trunk from the provider when "Register SIP Trunk" type is selected.
Password	Enter the password to register to the trunk from the provider when "Register SIP Trunk" is selected.
Auth ID	Enter the Authentication ID for "Register Trunk" type.
Outbound Proxy	Enter the IP address or URL of the outbound proxy for "Register SIP

	Trunk" type.
Auto Record	Enable automatic recording for the calls using this trunk (for SIP trunk only). The default setting is disabled. The recording files are saved in external storage if plugged in and can be accessed under web GUI-> CDR->Recording Files .
Peer SIP Trunk Configuration Parameters	
Provider Name	Configure the provider name for the VoIP trunk. This is a unique label to identify the trunk when listed in outbound rules, inbound rules and etc.
Host Name	Configure the IP address or URL for the VoIP provider server of the trunk.
Transport	Configure the SIP transport protocol to be used in this trunk. The default setting is "All - UDP Primary". <ul style="list-style-type: none"> • UDP Only • TCP Only • TLS Only • All - UDP Primary: UDP is the primary transport protocol when all the other SIP transport methods are available too. • All - TCP Primary: TCP is the primary transport protocol when all the other SIP transport methods are available too. • All - TLS Primary: TLS is the primary transport protocol when all the other SIP transport methods are available too.
Keep Trunk CID	If enabled, the trunk CID will not be overridden by extension's CID when the extension has CID configured. The default setting is "No".
Caller ID	Configure the Caller ID. This is the number that the trunk will try to use when making outbound calls. For some providers, it might not be possible to set the CallerID with this option and this option will be ignored. When making outgoing calls, the following rules are used to determine which CallerID will be used if they exist: <ul style="list-style-type: none"> • The CallerID configured for the extension will be looked up first. • If "Keep Trunk CID" is enabled, the CallerID configured for the trunk will be used. • If the above two are missing, the "Global Outbound CID" defined in web GUI->PBX->Internal Options->General will be used.
CallerID Name	Configure the name of the caller to be displayed when the extension has no CallerID Name configured.
Codec Preference	Select audio and video codec for the VoIP trunk. The available codecs are: PCMU, PCMA, GSM, AAL2-G.726-32, G.726, G.722, G.729, G.723, ILBC, ADPCM, H.264, H.263 and H.263p. In the selected codec list,

	users can click on UP or DOWN arrow to adjust the order for the codec priority using this trunk.
Auto Record	Enable automatic recording for the calls using this trunk. The default setting is disabled. The recording files are saved in external storage if plugged in and can be accessed under web GUI-> CDR -> Recording Files .
DID Mode	Configure where to get the destination ID of an incoming SIP call, from SIP Request-line or To-header. The default is set to "Request-line".
Enable Qualify	If enabled, the UCM6510 will regularly send SIP OPTIONS to the device to check if the device is still online. The default setting is "No".
Qualify Timeout	When "Enable Qualify" option is set to "Yes", configure the timeout (in ms) for the Qualify SIP message. If no response is received within the timeout, the device is considered offline. The default setting is 1000ms.
Qualify Frequency	When "Enable Qualify" option is set to "Yes", configure the interval (in seconds) of the SIP OPTIONS message sent to the device to check if the device is still online. The default setting is 60 seconds.
Fax Detection	Enable to detect Fax signal from the trunk during the call and send the received Fax to the default Email address in Fax setting page under web GUI->PBX->Internal Options->Fax/T.38. Note: If enabled, Fax Pass-through cannot be used.
S RTP	Enable SRTP for the VoIP trunk. The default setting is "No".
Sync LDAP Enable	If enabled, the local UCM6510 will automatically provide and update the local LDAP contacts to the remote UCM6510 SIP peer trunk. In order to ensure successful synchronization, the remote UCM6510 peer also needs to enable this option on the SIP peer trunk. The default setting is "No".
Sync LDAP Password	This is the password used for LDAP contact file encryption and decryption during the LDAP sync process. The password must be the same on both UCM6510 peers to ensure successful synchronization.
Sync LDAP Port	Configure the TCP port used LDAP sync feature between two peer UCM6510. It could be any open port available (not used by other services) on the UCM6510.
LDAP Outbound Rule	Specify an outbound rule for LDAP sync feature. The UCM6510 will automatically modify the remote contacts by adding prefix parsed from this rule.
LDAP Dialed Prefix	Specify the prefix for LDAP sync feature. The UCM6510 will automatically

	modify the remote contacts by adding this prefix.
Register SIP Trunk Configuration Parameters	
Provider Name	Configure the provider name for the VoIP trunk. This is a unique label to identify the trunk when listed in outbound rules, inbound rules and etc.
Host Name	Configure the IP address or URL for the VoIP provider server of the trunk.
Transport	<p>Configure the SIP transport protocol to be used in this trunk. The default setting is "All - UDP Primary".</p> <ul style="list-style-type: none"> • UDP Only • TCP Only • TLS Only • All - UDP Primary: UDP is the primary transport protocol when all the other SIP transport methods are available too. • All - TCP Primary: TCP is the primary transport protocol when all the other SIP transport methods are available too. • All - TLS Primary: TLS is the primary transport protocol when all the other SIP transport methods are available too.
Keep Trunk CID	When enabled, it can avoid overridden by extension's CID if the extension has CID configured. The default setting is enabled.
Username	Enter the username to register to the trunk from the provider.
Password	Enter the password to register to the trunk from the provider.
Auth ID	This is the authentication ID for the UCM6510 to register to the trunk if required by the provider. If not specified, the CallerID name will be used for authentication.
Codec Preference	Select audio and video codec for the VoIP trunk. The available codecs are: PCMU, PCMA, GSM, AAL2-G.726-32, G.726, G.722, G.729, G.723, ILBC, ADPCM, H.264, H.263 and H.263p. In the selected codec list, users can click on UP or DOWN arrow to adjust the order for the codec priority.
From Domain	<p>Configure the actual domain name where the extension comes from. This can be used to override the From Header.</p> <p>For example, "trunk.UCM6510.provider.com" is the From Domain in From Header: sip:1234567@trunk.UCM6510.provider.com.</p>
From User	<p>Configure the actual user name of the extension. This can be used to override the From Header. There are cases where there is a single ID for registration (single trunk) with multiple DIDs.</p> <p>For example, "1234567" is the From User in From Header: sip:1234567@trunk.UCM6510.provider.com.</p>

Outbound Proxy Support	Select to enable outbound proxy in this trunk. The default setting is "No".
Outbound Proxy	When outbound proxy support is enabled, enter the IP address or URL of the outbound proxy.
Auto Record	Enable automatic recording for the calls using this trunk. The default setting is disabled. The recording files can be accessed under web GUI->CDR->Recording Files.
DID Mode	Configure where to get the destination ID of an incoming SIP call, from SIP Request-line or To-header. The default is set to "Request-line".
Enable Qualify	If enabled, the UCM6510 will regularly send SIP OPTIONS to the device to check if the device is still online. The default setting is "No".
Qualify Timeout	When "Enable Qualify" option is set to "Yes", configure the timeout (in ms) for the Qualify SIP message. If no response is received within the timeout, the device is considered offline. The default setting is 1000ms.
Qualify Frequency	When "Enable Qualify" option is set to "Yes", configure the interval (in seconds) of the SIP OPTIONS message sent to the device to check if the device is still online. The default setting is 60 seconds.
Fax Detection	Enable to detect Fax signal from the trunk during the call and send the received Fax to the default Email address in Fax setting page under web GUI->PBX->Internal Options->Fax/T.38. Note: If enabled, Fax Pass-through cannot be used.
SRTP	Enable SRTP for the VoIP trunk. The default setting is "No".

Table 34: IAX Trunk Configuration Parameters

Create New IAX Trunk	
Type	Select the VoIP trunk type. <ul style="list-style-type: none"> Peer IAX Trunk Register IAX Trunk
Provider Name	Configure a unique label to identify this trunk when listed in outbound rules, inbound rules and etc.
Host Name	Configure the IP address or URL for the VoIP provider's server of the trunk.
Keep Trunk CID	If enabled, the trunk CID will not be overridden by extension's CID when the extension has CID configured. The default setting is "No".
Username	Enter the username to register to the trunk from the provider when "Register IAX Trunk" type is selected.

Password	Enter the password to register to the trunk from the provider when "Register IAX Trunk" type is selected.
Peer IAX Trunk Configuration Parameters	
Provider Name	Configure the provider name for the VoIP trunk. This is a unique label to identify the trunk when listed in outbound rules, inbound rules and etc.
Host Name	Configure the IP address or URL for the VoIP provider server of the trunk.
Keep Trunk CID	If enabled, the trunk CID will not be overridden by extension's CID when the extension has CID configured. The default setting is "No".
Caller ID	<p>Configure the Caller ID. This is the number that the trunk will try to use when making outbound calls. For some providers, it might not be possible to set the CallerID with this option and this option will be ignored.</p> <p>When making outgoing calls, the following rules are used to determine which CallerID will be used if they exist:</p> <ul style="list-style-type: none"> • The CallerID configured for the extension will be looked up first. • If "Keep Trunk CID" is enabled, no CallerID configured for the extension, the CallerID configured for the trunk will be used. • If the above two are missing, the "Global Outbound CID" defined in web GUI->PBX->Internal Options->General will be used.
CallerID Name	Configure the name of the caller to be displayed when the extension has no CallerID Name configured.
Codec Preference	Select audio and video codec for the VoIP trunk. The available codecs are: PCMU, PCMA, GSM, AAL2-G.726-32, G.726, G.722, G.729, G.723, ILBC, ADPCM, H.264, H.263, H.263p.
Enable Qualify	If enabled, the UCM6510 will regularly send SIP OPTIONS to the device to check if the device is still online. The default setting is "No".
Qualify Timeout	When "Enable Qualify" option is set to "Yes", configure the timeout (in ms) for the Qualify SIP message. If no response is received within the timeout, the device is considered offline. The default setting is 1000ms.
Qualify Frequency	When "Enable Qualify" option is set to "Yes", configure the interval (in seconds) of the SIP OPTIONS message sent to the device to check if the device is still online. The default setting is 60 seconds.
Fax Detection	<p>Enable to detect Fax signal from the trunk during the call and send the received Fax to the default Email address in Fax setting page under web GUI->PBX->Internal Options->Fax/T.38.</p> <p>Note: If enabled, Fax Pass-through cannot be used.</p>

Register IAX Trunk Configuration Parameters

Provider Name	Configure the provider name for the VoIP trunk. This is a unique label to identify the trunk when listed in outbound rules, inbound rules and etc.
Host Name	Configure the IP address or URL for the VoIP provider server of the trunk.
Keep Trunk CID	When enabled, it can avoid overridden by extension's CID if the extension has CID configured. The default setting is enabled.
Caller ID	<p>Configure the Caller ID. This is the number that the trunk will try to use when making outbound calls. For some providers, it might not be possible to set the CallerID with this option and this option will be ignored.</p> <p>When making outgoing calls, the following rules are used to determine which CallerID will be used if they exist:</p> <ul style="list-style-type: none"> • The CallerID configured for the extension will be looked up first. • If no CallerID configured for the extension, the CallerID configured for the trunk will be used. • If the above two are missing, the "Global Outbound CID" defined in web GUI->PBX->Internal Options->General will be used.
CallerID Name	Configure the name of the caller to be displayed when the extension has no CallerID Name configured.
Username	Enter the username to register to the trunk from the provider.
Password	Enter the password to register to the trunk from the provider.
Auth ID	This is the authentication ID for the UCM6510 to register to the trunk if required by the provider. If not specified, the CallerID name will be used for authentication.
Codec Preference	Select audio and video codec for the VoIP trunk. The available codecs are: PCMU, PCMA, GSM, AAL2-G.726-32, G.726, G.722, G.729, G.723, ILBC, ADPCM, H.264, H.263 and H.263p. In the selected codec list, users can click on UP or DOWN arrow to adjust the order for the codec priority.
Enable Qualify	If enabled, the UCM6510 will regularly send SIP OPTIONS to the device to check if the device is still online. The default setting is "No".
Qualify Timeout	When "Enable Qualify" option is set to "Yes", configure the timeout (in ms) for the Qualify SIP message. If no response is received within the timeout, the device is considered offline. The default setting is 1000ms.
Qualify Frequency	When "Enable Qualify" option is set to "Yes", configure the interval (in seconds) of the SIP OPTIONS message sent to the device to check if the device is still online. The default setting is 60 seconds.

Fax Detection

Enable to detect Fax signal from the trunk during the call and send the received Fax to the default Email address in Fax setting page under web GUI->PBX->Internal Options->Fax/T.38.

Note:

If enabled, Fax Pass-through cannot be used.



DIRECT OUTWARD DIALING (DOD) VIA VOIP TRUNKS

The UCM6510 provides Direct Outward Dialing (DOD) which is a service of a local phone company (or local exchange carrier) that allows subscribers within a company's PBX system to connect to outside lines directly.

Example of how DOD is used:

Company ABC has a SIP trunk. This SIP trunk has 4 DID's associated to it. The main number of the office is routed to an auto attendant. The other three numbers are direct lines to specific users of the company. At the moment when a user makes an outbound call their caller ID shows up as the main office number. This poses a problem as the CEO would like their calls to come from their direct line. This can be accomplished by configuring DOD for the CEO's extension.

Steps on how to configure DOD on the UCM:

1. To setup DOD go to UCM6510 web GUI->**PBX->Basic/Call Routes->VoIP Trunks** page.
2. Click  to access the DOD options for the selected SIP Trunk.
3. Click "Create a new DOD" to begin your DOD setup.
4. For "DOD Number" enter one of the numbers (DIDs) from your SIP trunk provider. In the example above Company ABC received 4 DID's from their provider. ABC will enter in the number for the CEO's direct line.
5. Select an extension from the "Available Extensions" list. Users have the option of selecting more than one extension. In this case, Company ABC would select the CEO's extension. After making the selection, click on the  button to move the extension(s) to the "Selected Extensions" list.

Edit DOD

Direct Outward Dialing (DOD) is a service of a local phone company (or local exchange carrier) that allows subscribers within a company's PBX system to connect to outside lines directly.

DOD Number:

Available Extensions

5001

5003

5000

⊕

➤

➤

⊖

Selected Extensions

5004

Figure 48: DOD extension selection



6. Click "Save" at the bottom.

Once completed, the user will return to the **Edit DOD** page that shows all the extensions that are associated to a particular DOD.

Edit DOD

Direct Outward Dialing (DOD) is a service of a local phone company (or local exchange carrier) that allows subscribers within a company's PBX system to connect to outside lines directly.

Create a new DOD
Edit DOD

DOD	Extensions	Options
6176518241	5002	
4451234567	5005	

Total: **2** Show: **1/1** Go to: Go

First
Prev
Next
Last

Figure 49: Edit DOD

This page intentionally left blank

CALL ROUTES

OUTBOUND ROUTES

In the UCM6510, an outgoing calling rule pairs an extension pattern with a trunk used to dial the pattern. This allows different patterns to be dialed through different trunks (e.g., "Local" 7-digit dials through a FXO while "Long distance" 10-digit dials through a low-cost SIP trunk). Users can also set up a failover trunk to be used when the primary trunk fails.

Go to web GUI->**PBX->Basic/Call Routes->Outbound Routes** to add and edit outbound rules.







- Click on "Create New Outbound Rule" to add a new outbound route.
- Click on  to edit the outbound route.
- Click on  to delete the outbound route.
- On the UCM6510, the outbound route priority is based on "Best matching pattern". For example, the UCM6510 has outbound route A with pattern 1xxx and outbound route B with pattern 10xx configured. When dialing 1000 for outbound call, outbound route B will always be used first. This is because pattern 10xx is a better match than pattern 1xxx. Only when there are multiple outbound routes with the same pattern configured, users can click on     to move the outbound route up/down to arrange the priority among those outbound routes.

Table 35: Outbound Route Configuration Parameters



Calling Rule Name	Configure the name of the calling rule (e.g., local, long_distance, and etc). Letters, digits, _ and - are allowed.
Pattern	<ul style="list-style-type: none"> • All patterns are prefixed with the "_". • Special characters: X: Any Digit from 0-9. Z: Any Digit from 1-9. N: Any Digit from 2-9. ".": Wildcard. Match one or more characters. "!": Wildcard. Match zero or more characters immediately. Example: [12345-9] - Any digit from 1 to 9.
Password	Configure the password for users to use this rule when making outbound calls.

<p>Privilege Level</p>	<p>Select privilege level for the outbound rule.</p> <ul style="list-style-type: none"> • Internal: The lowest level required. All users can use this rule. • Local: Users with Local, National, or International level are allowed to use this rule. • National: Users with National or International level are allowed to use this rule. • International: The highest level required. Only users with international level can use this rule. <p>The default setting is "Disable". Please be aware of the potential security risks when using "Internal" level, which means all users can use this outbound rule to dial out from the trunk.</p>
<p>Enable Filter on Source Caller ID</p>	<p>When enabled, users could specify extensions allowed to use this outbound route. "Privilege Level" is automatically disabled if using "Enable Filter on Source Caller ID".</p> <p>The following two methods can be used at the same time to define the extensions as the source caller ID.</p> <ol style="list-style-type: none"> 1. Select available extensions/extension groups from the left to the right. This allows users to specify arbitrary single extensions available in the PBX. 2. Custom Dynamic Route: define the pattern for the source caller ID. This allows users to define extension range instead of selecting them one by one. <ul style="list-style-type: none"> • All patterns are prefixed with the "_". • Special characters: X: Any Digit from 0-9. Z: Any Digit from 1-9. N: Any Digit from 2-9. ".": Wildcard. Match one or more characters. "!": Wildcard. Match zero or more characters immediately. Example: [12345-9] - Any digit from 1 to 9.
<p>Send This Call Through Trunk</p>	
<p>Use Trunk</p>	<p>Select the trunk for this outbound rule.</p>
<p>Strip</p>	<p>Allows the user to specify the number of digits that will be stripped from the beginning of the dialed string before the call is placed via the selected trunk.</p> <p>Example:</p> <p>The users will dial 9 as the first digit of a long distance calls. However, 9 should not be sent out via analog lines and the PSTN line. In this case, 1</p>

	digit should be stripped before the call is placed.
Prepend	Specify the digits to be prepended before the call is placed via the trunk. Those digits will be prepended after the dialing number is stripped.
Use Failover Trunk	
Failover Trunk	<p>Failover trunks can be used to make sure that a call goes through an alternate route, when the primary trunk is busy or down. If "Use Failover Trunk" is enabled and "Failover trunk" is defined, the calls that cannot be placed via the regular trunk may have a secondary trunk to go through.</p> <p>Example: The user's primary trunk is a VoIP trunk and the user would like to use the PSTN when the VoIP trunk is not available. The PSTN trunk can be configured as the failover trunk of the VoIP trunk.</p>
Strip	<p>Allows the user to specify the number of digits that will be stripped from the beginning of the dialed string before the call is placed via the selected trunk.</p> <p>Example: The users will dial 9 as the first digit of a long distance calls. However, 9 should not be sent out via analog lines and the PSTN line. In this case, 1 digit should be stripped before the call is placed.</p>
Prepend	Specify the digits to be prepended before the call is placed via the trunk. Those digits will be prepended after the dialing number is stripped.

INBOUND ROUTES

Inbound routes can be configured via web GUI->**PBX->Basic/Call Routes->Inbound Routes**.

- Click on "Create New Inbound Rule" button to add a new inbound route.
- Click on "Blacklist" button to configure blacklist for all inbound routes.
- Click on  to edit the inbound route.
- Click on  to delete the inbound route.

INBOUND RULE CONFIGURATIONS

Table 36: Inbound Rule Configuration Parameters

Trunks	Select the trunk to configure the inbound rule.
DID Pattern	<ul style="list-style-type: none"> • All patterns are prefixed with the "_". • Special characters: X: Any Digit from 0-9. Z: Any Digit from 1-9. N: Any Digit from 2-9. ".": Wildcard. Match one or more characters. "!": Wildcard. Match zero or more characters immediately. Example: [12345-9] - Any digit from 1 to 9. • The pattern can be composed of two parts, divided by a '/' character. The first part is used to specify the dialed number the second part is used to specify the caller ID and it is optional, if set it means only the extension with the specific caller ID is allowed to call in or call out. For example, patter '_2XXX/1234' means the only extension with the caller ID '1234' is allowed to use this rule.
Privilege Level	<p>Select privilege level for the inbound rule when a VoIP trunk is selected in "Trunks" field.</p> <ul style="list-style-type: none"> • Internal: The lowest level required. All users can use this rule. • Local: Users with Local, National or International level are allowed to use this rule. • National: Users with National or International level are allowed to use this rule. • International: The highest level required. Only users with international level can use this rule. <p>This setting is used to compare with the outbound trunk's permission level when the inbound call dials out via a trunk on the UCM6510. Therefore, it's usually used only when the "Default Destination" is set to "By DID".</p>
Default Destination	<p>Select the default destination for the inbound call.</p> <ul style="list-style-type: none"> • Extension • Voicemail • Conference Room • Call Queue • Ring Group • Paging/Intercom • Voicemail Group • Fax • DISA

	<ul style="list-style-type: none"> • IVR • By DID When "By DID" is used, the UCM6510 will look for the destination based on the number dialed, which could be local extensions, conference, call queue, ring group, paging/intercom group, IVR, voicemail groups and Fax extension as configured in "DID destination". If the dialed number matches the DID pattern, the call will be allowed to go through. • Dial By Name
Strip	Specify the number of digits to strip from the beginning of the DID. This is used when "By DID" is selected in "Default Destination".
Dial Trunk	Configure to allow the inbound call to dial out from the PBX's trunk or not. The default setting is disabled. Please be aware of potential security risk if "Dial Trunk" is enabled. The inbound call might be able to dial out international calls from the PBX's trunk if allowed by the privilege level.
DID Destination	<p>Select the DID destination if "By DID" is selected in "Default Destination". Only the selected category can be reached by DID using this inbound route.</p> <ul style="list-style-type: none"> • Extension • Conference • Call Queue • Ring Group • Paging/Intercom Group • IVR • Voicemail Groups • Fax Extension • Dial By Name
Time Condition	
Start Time	Select the start time "hour:minute" for the trunk to use the inbound rule.
End Time	Select the end time "hour:minute" for the trunk to use the inbound rule.
Date	Select "By Week" or "By Day" and specify the date for the trunk to use the inbound rule.
Week	Select the day in the week to use the inbound rule.
Destination	<p>Select the destination for the inbound call under the defined time condition.</p> <ul style="list-style-type: none"> • Extension • Voicemail • Conference Room • Call Queue

- Ring Group
- Paging/Intercom
- Voicemail Group
- Fax
- DISA
- IVR
- By DID

When "By DID" is used, the UCM6510 will look for the destination based on the number dialed, which could be local extensions, conference, call queue, ring group, paging/intercom group, IVR, voicemail groups and Fax extension as configured in "DID destination". If the dialed number matches the DID pattern, the call will be allowed to go through.

Configure the number of digits to be stripped in "Strip" option.
- Dial By Name

BLACKLIST CONFIGURATIONS

In the UCM6510, Blacklist is supported for all inbound routes. Users could enable the Blacklist feature, manage the Blacklist by clicking on "Blacklist".

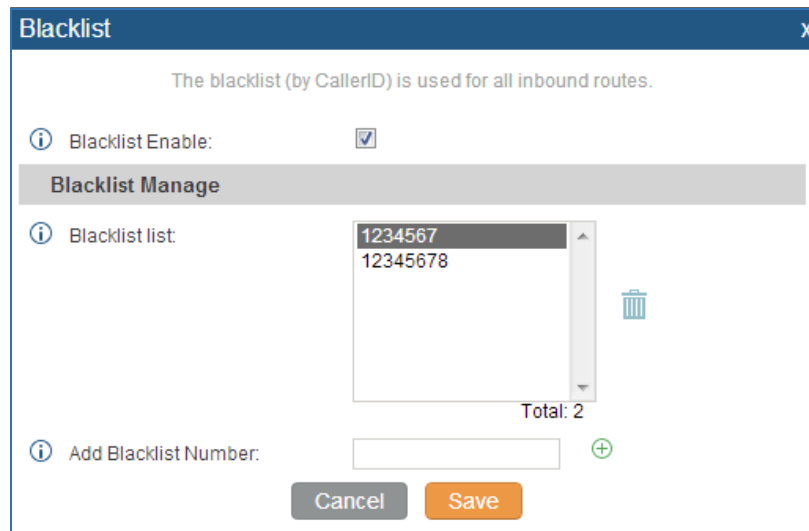



Figure 50: Blacklist Configuration Parameters

- Select the checkbox for "Blacklist Enable" to turn on Blacklist feature for all inbound routes. Blacklist is disabled by default.
- Enter a number in "Add Blacklist Number" field and then click  to add to the list.

- To remove a number from the Blacklist, select the number in "Blacklist list" and click on  .

 **Note:**

Users could also add a number to the Blacklist or remove a number from the Blacklist by dialing the feature code for "Blacklist Add" (default: *40) and "Blacklist Remove" (default: *41) from an extension. The feature code can be configured under web GUI->**PBX->Internal Options->Feature Codes**.

This page intentionally left blank

CONFERENCE BRIDGE

The UCM6510 supports Conference Bridge allowing 64 participants with up to 8 bridges at the same time. The conference bridge configurations can be accessed under web GUI->**PBX->Call Features->Conference**. In this page, users could create, edit, view, invite, manage the participants and delete conference bridges. The conference bridge status and conference call recordings (if recording is enabled) will be displayed in this web page as well.

CONFERENCE BRIDGE CONFIGURATIONS



- Click on "Create New Conference Room" to add a new conference bridge.
- Click on  to edit the conference bridge.
- Click on  to delete the conference bridge.

Table 37: Conference Bridge Configuration Parameters

Extension	Configure the conference number for the users to dial into the conference.
Password	<p>When configured, the users who would like to join the conference call must enter this password before accessing the conference bridge.</p> <p>Note:</p> <ul style="list-style-type: none"> • If "Public Mode" is enabled, the password is not required to join the conference bridge thus this field is invalid. • The password has to be at least 4 characters.
Admin Password	<p>Configure the password to join the conference bridge as administrator. Conference administrator can manage the conference call via IVR (if "Enable Caller Menu" is enabled) as well as invite other parties to join the conference by dialing "0" (permission required from the invited party) or "1" (permission not required from the invited party) during the conference call.</p> <p>Note:</p> <ul style="list-style-type: none"> • If "Public Mode" is enabled, the password is not required to join the conference bridge thus this field is invalid. • The password has to be at least 4 characters.

Enable Caller Menu	If enabled, conference participant could press the * key to access the conference bridge menu. The default setting is "No".
Record Conference	If enabled, the calls in this conference bridge will be recorded automatically in a .wav format file. All the recording files will be displayed and can be downloaded in the conference web page. The default setting is "No".
Quiet Mode	<p>If enabled, if there are users joining or leaving the conference, voice prompt or notification tone won't be played. The default setting is "No".</p> <p>Note: "Quiet Mode" and "Announce Callers" cannot be enabled at the same time.</p>
Wait For Admin	<p>If enabled, the participants will not hear each other until the conference administrator joins the conference. The default setting is "No".</p> <p>Note: If "Quiet Mode" is enabled, the voice prompt for "Wait For Admin" will not be announced.</p>
Enable User Invite	<p>If enabled, users could press 0 to invite other users (with the users' permission) or press 1 to invite other users (without the user's permission) to join the conference. The default setting is "No".</p> <p>Note: Conference administrator can always invite other users without enabling this option.</p>
Announce Callers	<p>If enabled, the caller will be announced to all conference participants when there the caller joins the conference. The default setting is "No".</p> <p>Note: "Quiet Mode" and "Announce Callers" cannot be enabled at the same time.</p>
Public Mode	If enabled, no authentication will be required when joining the conference call. The default setting is "Yes".
Play Hold Music For First Caller	If enabled, the UCM6510 will play Hold music to the first participant in the conference until another user joins in. The default setting is "No".
Music On Hold	Select the music on hold class to be played in conference call. This option shows up if "Play Hold Music For First Caller" is enabled. Music On Hold class can be set up under web UI-> PBX->Internal Options->Music On Hold .

Skip Authentication When Inviting User via Trunk from web GUI

If enabled, the invitation from web GUI for a conference bridge with password will skip the authentication for the invited users. The default setting is "No".

JOIN A CONFERENCE CALL

Users could dial the conference bridge extension to join the conference. If password is required, enter the password to join the conference as a normal user, or enter the admin password to join the conference as administrator.

INVITE OTHER PARTIES TO JOIN CONFERENCE

When using the UCM6510 conference bridge, there are two ways to invite other parties to join the conference.

- Invite from web GUI.

For each conference bridge in UCM6510 web GUI->**PBX**->**Call Features**->**Conference**, there is an icon  for option "Invite a participant". Click on it and enter the number of the party you would like to invite. Then click on "Add". A call will be sent to this number to join it into the conference.

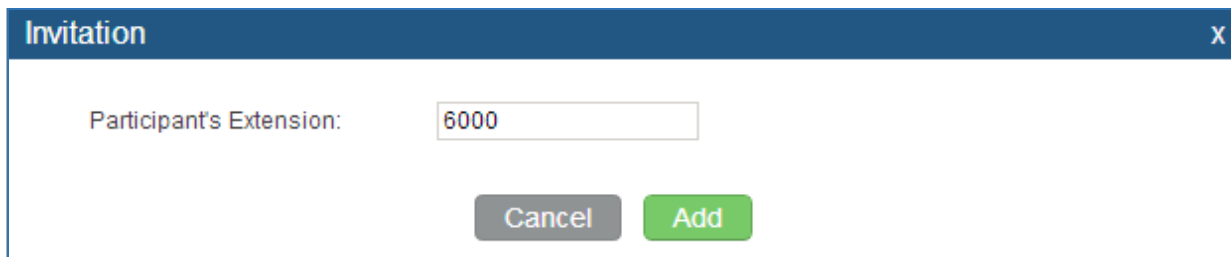

Figure 51: Conference Invitation From web GUI

- Invite by dialing 0 or 1 during conference call.

A conference participant can invite other parties to the conference by dialing from the phone during the conference call. Please make sure option "Enable User Invite" is turned on for the conference bridge first. Enter 0 or 1 during the conference call. Follow the voice prompt to input the number of the party you would like to invite. A call will be sent to this number to join it into the conference.

0: If 0 is entered to invite other party, once the invited party picks up the invitation call, a permission will be asked to "accept" or "reject" the invitation before joining the conference.

1: If 1 is entered to invite other party, no permission will be required from the invited party.

 **Note:**





Conference administrator can always invite other parties from the phone during the call by entering 0 or 1. To join a conference bridge as administrator, enter the admin password when joining the conference. A conference bridge can have multiple administrators.

DURING THE CONFERENCE

During the conference call, users can manage the conference from web GUI or IVR.

- Manage the conference call from web GUI.

Log in UCM6510 web GUI during the conference call, the participants in each conference bridge will be listed.

1. Click on  to kick a participant from the conference.
2. Click on  to mute the participant.
3. Click on  to lock this conference bridge so that other users cannot join it anymore.
4. Click on  to invite other users into the conference bridge.

- Manage the conference call from IVR.

If "Enable Caller Menu" is enabled, conference participant can input * to enter the IVR menu for the conference. Please see options listed in the table below.

Table 38: Conference Caller IVR Menu

Conference Administrator IVR Menu	
1	Mute/unmute yourself.
2	Lock/unlock the conference bridge.
3	Kick the last joined user from the conference.
4	Decrease the volume of the conference call.
6	Increase the volume of the conference call.
7	Decrease your volume.
9	Increase your volume.
8	More options: <ul style="list-style-type: none"> • 1: List all users currently in the conference call. • 2: Kick all non-Administrator participants from the conference call. • 3: Mute/Unmute all non-Administrator participants from the conference call. • 4: Enable/disable conference call recording. • 8: Exit the caller menu and return to the conference.
Conference User IVR Menu	
1	Mute/unmute yourself.
4	Decrease the volume of the conference call.
6	Increase the volume of the conference call.
7	Decrease your volume.
9	Increase your volume.
8	Exit the caller menu and return to the conference.





Note:

When there is participant in the conference, the conference bridge configuration cannot be modified.

RECORD CONFERENCE

The UCM6510 allows users to record the conference call and retrieve the recording from web GUI->**PBX->Call Features->Conference.**

To record the conference call, when the conference bridge is in idle, enable "Record Conference" from the conference bridge configuration dialog. Save the setting and apply the change. When the conference call starts, the call will be automatically recorded in .wav format.

The recording files will be listed as below once available. Users could click on  to download the recording or click on  to delete the recording.



















Name	Room	Date	Size	Options
meetme-conf-rec-6300-1372865271.25.wav	6300	2013-07-03 12:39:38 UTC-03:00	10.61 MB	 
meetme-conf-rec-6300-1372451238.6.wav	6300	2013-06-28 17:27:46 UTC-03:00	120.04 KB	 
meetme-conf-rec-6300-1372205127.347.wav	6300	2013-06-25 21:05:56 UTC-03:00	82.86 KB	 
meetme-conf-rec-6300-1372867161.40.wav	6300	2013-07-03 13:10:29 UTC-03:00	10.17 MB	 
meetme-conf-rec-6300-1372864546.12.wav	6300	2013-07-03 12:16:01 UTC-03:00	35.67 KB	 
meetme-conf-rec-6300-1372866438.36.wav	6300	2013-07-03 12:47:47 UTC-03:00	322.86 KB	 
meetme-conf-rec-6300-1372204987.337.wav	6300	2013-06-25 21:03:30 UTC-03:00	315.98 KB	 
meetme-conf-rec-6300-1372864583.17.wav	6300	2013-07-03 12:16:36 UTC-03:00	65.67 KB	 
meetme-conf-rec-6300-1370385024.71.wav	6300	2013-06-04 19:35:28 UTC-03:00	4.22 MB	 

Figure 52: Conference Recording

IVR

CONFIGURE IVR

IVR configurations can be accessed under the UCM6510 web GUI->**PBX->Call Features->IVR**. Users could create, edit, view and delete an IVR.



- Click on "Create New IVR" to add a new IVR.
- Click on  to edit the IVR configuration.
- Click on  to delete the IVR.

Table 39: IVR Configuration Parameters

Name	Configure the name of the IVR. Letters, digits, _ and - are allowed.
Extension	Enter the extension number for users to access the IVR.
Dial Other Extensions	If enabled, all callers to the IVR can dial other extensions. The default setting is "No".
Dial Trunk	If enabled, all callers to the IVR is allowed to use trunk. The permission must be configured for the users to use the trunk first. The default setting is "No".
Permission	Assign permission level for outbound calls if "Dial Trunk" is enabled. The available permissions are "Internal", "Local", "National" and "International" from the lowest level to the highest level. The default setting is "Internal". If the user tries to dial outbound calls after dialing into the IVR, the UCM6510 will compared the IVR's permission level with the outbound route's privilege level. If the IVR's permission level is higher than (or equal to) the outbound route's privilege level, the call will be allowed to go through.
Welcome Prompt	Select an audio file to play as the welcome prompt for the IVR. Click on "Prompt" to add additional audio file under web GUI-> Internal Options->IVR Prompt .
Digit Timeout	Configure the timeout between digit entries. After the user enters a digit, the user needs to enter the next digit within the timeout. If no digit is detected within the timeout, the UCM6510 will consider the entries complete. The default timeout is 3 seconds.
Response Timeout	After playing the prompts in the IVR, the UCM6510 will wait for the DTMF

	entry within the timeout (in seconds). If no DTMF entry is detected within the timeout, a timeout prompt will be played. The default setting is 10 seconds.
Response Timeout Prompt	Select the prompt message to be played when timeout occurs.
Invalid Prompt	Select the prompt message to be played when an invalid extension is pressed.
Response Timeout Repeat Loops	Configure the number of times to repeat the prompt if no DTMF input is detected. When the loop ends, it will go to the timeout destination if configured, or hang up. The default setting is 3.
Invalid Repeat Loops	Configure the number of times to repeat the prompt if the DTMF input is invalid. When the loop ends, it will go to the invalid destination if configured, or hang up. The default setting is 3.
Language	Select the voice prompt language to be used for this IVR. The default setting is "Default" which is the selected voice prompt language under web GUI-> PBX->Internal Options->Language . The dropdown list shows all the current available voice prompt languages on the UCM6510. To add more languages in the list, please download voice prompt package by selecting "Check Prompt List" under web GUI-> PBX->Internal Options->Language .
Key Press Event	Select the event for each key pressing for 0-9, *, Timeout and Invalid. The event options are: <ul style="list-style-type: none"> • Extension • Voicemail • Conference Rooms • Voicemail Group • IVR • Ring Group • Queues • Page Group • Fax • IVR Prompt • Hangup • DISA • Dial By Name

CREATE IVR PROMPT

To record new IVR prompt or upload IVR prompt to be used in IVR, click on "Prompt" next to the "Welcome Prompt" option and the users will be redirected to IVR Prompt page. Or users could go to web GUI->**PBX->Internal Options->IVR Prompt** page directly.

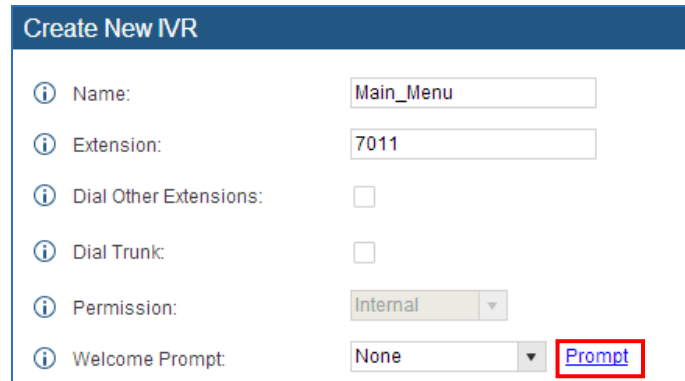

Create New IVR

Name: Main_Menu

Extension: 7011

Dial Other Extensions:

Dial Trunk:

Permission: Internal

Welcome Prompt: None **Prompt**

Figure 53: Click On Prompt To Create IVR Prompt

Once the IVR prompt file is successfully added to the UCM6510, it will be added into the prompt list options for users to select in different IVR scenarios.

RECORD NEW IVR PROMPT

In the UCM6510 web GUI->**PBX->Internal Options->IVR Prompt** page, click on "Record New IVR Prompt" and follow the steps below to record new IVR prompt.

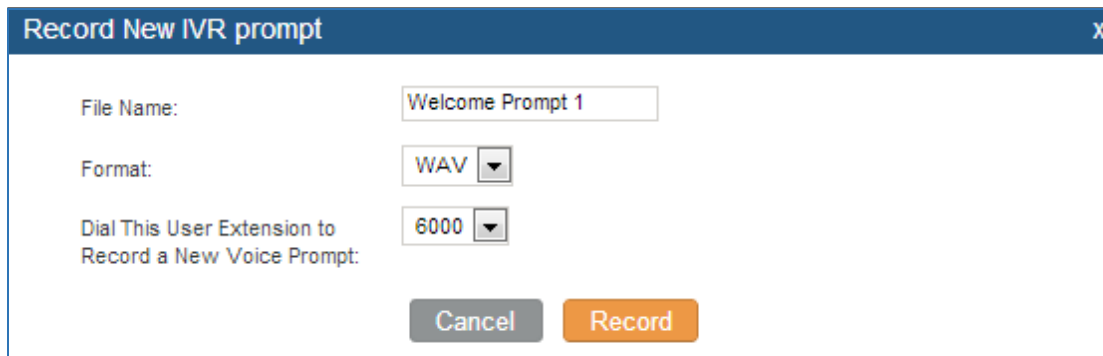

Record New IVR prompt

File Name: Welcome Prompt 1

Format: WAV

Dial This User Extension to Record a New Voice Prompt: 6000

Cancel Record

Figure 54: Record New IVR Prompt

- Specify the IVR file name.
- Select the format (GSM or WAV) for the IVR prompt file to be recorded.
- Select the extension to receive the call from the UCM6510 to record the IVR prompt.

- Click the "Record" button. A request will be sent to the UCM6510. The UCM6510 will then call the extension for recording the IVR prompt from the phone.
- Pick up the call from the extension and start the recording following the voice prompt.
- The recorded file will be listed in the IVR Prompt web page. Users could select to re-record, play or delete the recording.

UPLOAD IVR PROMPT

If the user has a pre-recorded IVR prompt file, click on "Upload IVR Prompt" in web GUI->**PBX->Internal Options->IVR Prompt** page to upload the file to the UCM6510. The following are required for the IVR prompt file to be successfully uploaded and used by the UCM6510:

- PCM encoded.
- 16 bits.
- 8000Hz mono.
- In .mp3 or .wav format; or raw/ulaw/alaw/gsm file with .ulaw or .alaw suffix.
- File size under 5M.

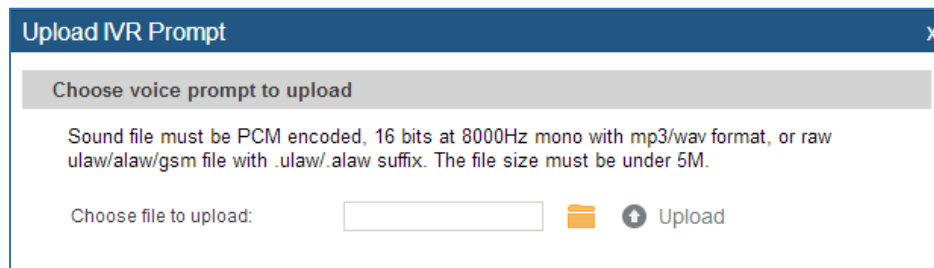



Figure 55: Upload IVR Prompt

Click on  to select audio file from local PC and click on  to start uploading. Once uploaded, the file will appear in the IVR Prompt web page.

LANGUAGE SETTINGS FOR VOICE PROMPT

The UCM6510 supports multiple languages in web GUI as well as system voice prompt. The following languages are currently supported in system voice prompt:

- English (United States)
- Arabic
- Chinese
- Dutch
- English (United Kingdom)
- French
- German
- Greek
- Hebrew
- Italian
- Polish
- Portuguese
- Russian
- Spanish
- Swedish
- Turkish

English (United States) and Chinese voice prompts are built in with the UCM6510 already. The other languages provided by Grandstream can be downloaded and installed from the UCM6510 web GUI directly. Additionally, users could customize their own voice prompts, package them and upload to the UCM6510.

Language settings for voice prompt can be accessed under web GUI->**PBX->Internal Options->Language**.

DOWNLOAD AND INSTALL VOICE PROMPT PACKAGE

To download and install voice prompt package in different languages from UCM6510 web GUI, click on "Check Prompt List" button.

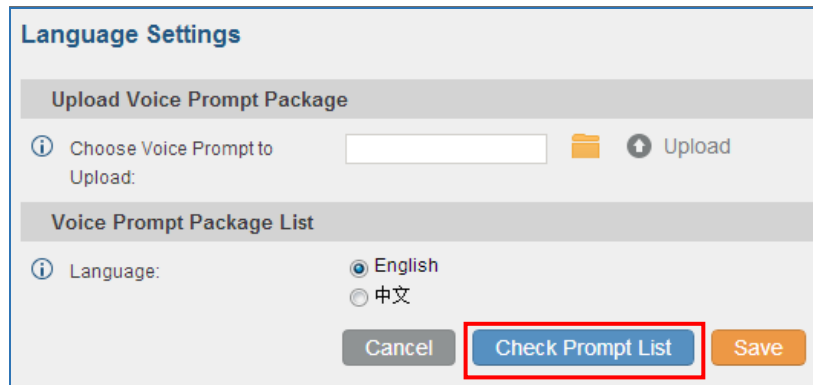



Figure 56: Language Settings for Voice Prompt

A new dialog window of voice prompt package list will be displayed. Users can see the version number (latest version available V.S. current installed version), package size and options to upgrade or download the language.

Voice Prompt Package List	Version (Remote / Local)	Size	Options
British English	1.0/-	3.7M	↓
Deutsch	1.1/-	3.5M	↓
English	1.0/1.0	5.1M	ⓘ
Español	1.1/-	3.7M	↓
Ελληνικά	1.0/-	3.6M	↓
Français	1.0/-	3.5M	↓
Italiano	1.0/-	3.4M	↓
Nederlands	1.0/-	3.0M	↓
Polski	1.0/-	4.2M	↓
Português	1.1/-	3.7M	↓
Русский	1.1/-	3.2M	↓
Svenska	1.0/-	3.9M	↓
Türkçe	1.0/-	3.1M	↓
עברית	1.0/-	3.4M	↓
العربية	1.1/-	4.3M	↓

Figure 57: Voice Prompt Package List

Click on  to download the language to the UCM6510. The installation will be automatically started once the downloading is finished.

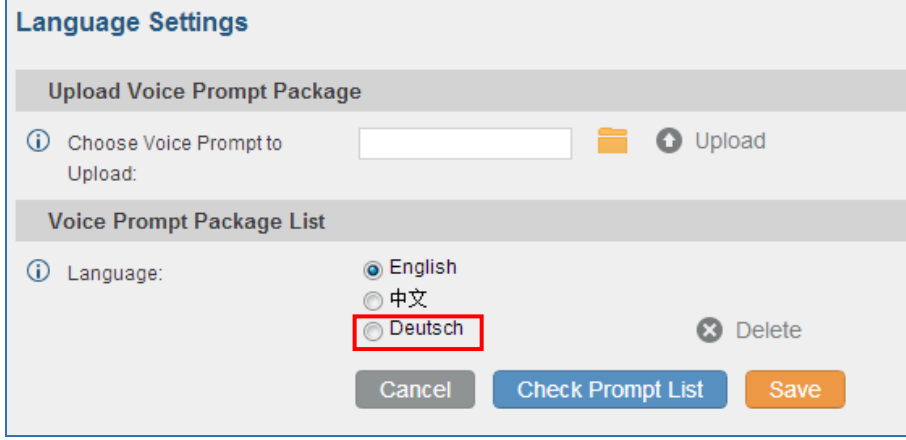

The screenshot shows the 'Language Settings' interface. It is divided into two main sections: 'Upload Voice Prompt Package' and 'Voice Prompt Package List'.
1. 'Upload Voice Prompt Package': Contains a text input field for 'Choose Voice Prompt to Upload:', a folder icon, and an 'Upload' button.
2. 'Voice Prompt Package List': Contains a 'Language:' label followed by three radio button options: 'English' (selected), '中文', and 'Deutsch' (highlighted with a red box). To the right of these options is a 'Delete' button with an 'x' icon.
At the bottom of the interface are three buttons: 'Cancel', 'Check Prompt List', and 'Save'.

Figure 58: New Voice Prompt Language Added

A new language option will be displayed after successfully installed. Users then could select it to apply in the UCM6510 system voice prompt or delete it from the UCM6510.

This page intentionally left blank

VOICEMAIL

CONFIGURE VOICEMAIL

If the voicemail is enabled for UCM6510 extensions, the configurations of the voicemail can be globally set up and managed under web GUI->**PBX->Call Features->Voicemail**.

Table 40: Voicemail Settings

Max Greeting	Configure the maximum number of seconds for the voicemail greeting. The default setting is 60 seconds.
Dial '0' For Operator	If enabled, the caller can press 0 to exit the voicemail application and connect to the configured operator's extension. The operator extension can be configured under web GUI-> PBX->Internal Options->General .
Max Messages Per Folder	Configure the maximum number of messages per folder in users' voicemail. The valid range 10 to 1000. The default setting is 50.
Max Message Time	<p>Select the maximum duration of the voicemail message. The message will not be recorded if the duration exceeds the max message time. The default setting is 15 minutes. The available options are:</p> <ul style="list-style-type: none"> • 1 minute • 2 minutes • 5 minutes • 15 minutes • 30 minutes • Unlimited
Min Effective Message Time	<p>Configure the minimum effective duration (in seconds) of a voicemail message. Messages will be automatically deleted if the duration is shorter than the Min Effective Message Time. The default setting is 3 seconds. The available options are:</p> <ul style="list-style-type: none"> • No minimum • 1 second • 2 seconds • 3 seconds • 4 seconds • 5 seconds <p>Note: Silence and noise duration are not counted in message time.</p>
Announce Message Caller-ID	If enabled, the caller ID of the user who has left the message will be

	announced at the beginning of the voicemail message. The default setting is "No".
Announce Message Duration	If enabled, the message duration will be announced at the beginning of the voicemail message. The default setting is "No".
Play Envelope	If enabled, a brief introduction (received time, received from, and etc) of each message will be played when accessed from the voicemail application. The default setting is "Yes".
Allow User Review	If enabled, users can review the message following the IVR before sending the message out. The default setting is "No".

ACCESS VOICEMAIL

If the voicemail is enabled for UCM6510 extensions, the users can dial the voicemail access feature code (by default *98 or *97) to access the extension's voicemail. The users will be prompt to enter the voicemail password and then can enter digits from the phone keypad to navigate in the IVR menu for different options.

Table 41: Voicemail IVR Menu

Main Menu	Sub Menu 1	Sub Menu 2
1 - New messages	3 - Advanced options	1 - Send a reply
		2 - Call the person who sent this message
		3 - Hear the message envelop
		4 - Leave a message
		* - Return to the main menu
	5 - Repeat the current message	
	7 - Delete this message	
	8 - Forward the message to another user	
2 - Change folders	9 - Save	
	* - Help	
	# - Exit	
	0 - New messages	
	1 - Old messages	
	2 - Work messages	
	3 - Family messages	
	4 - Friend messages	

	# - Cancel	
3 - Advanced options	1 - Send a reply	
	2 - Call the person who sent this message	
	3 - Hear the message envelop	
	4 - Leave a message	
	* - Return to the main menu	
0 - Mailbox options	1 - Record your unavailable message	1 - Accept this recording
		2 - Listen to it
		3 - Re-record your message
	2 - Record your busy message	1 - Accept this recording
		2 - Listen to it
		3 - Re-record your message
	3 - Record your name	1 - Accept this recording
		2 - Listen to it
		3 - Re-record your message
	4 - Record temporary greeting	1 - Accept this recording
		2 - Listen to it
		3 - Re-record your message
	5 - Change your password	
* - Return to the main menu		

VOICEMAIL EMAIL SETTINGS

The UCM6510 can be configured to send the voicemail as attachment to Email. Click on "Voicemail Email Settings" button to configure the Email attributes and content.

VoiceMail Email Settings
X

i Attach Recordings to E-mail:

Template for Voicemail Emails

Template Variables: \t : TAB

\${VM_NAME} : Recipient's firstname and lastname

\${VM_DUR} : The duration of the voicemail message

\${VM_MAILBOX} : The recipient's extension

\${VM_CALLERID} : The caller ID of the person who has left the message

\${VM_MSGNUM} : The message number in the mailbox

\${VM_DATE} : The date and time when the message was left

Subject:

Message:

Hello \${VM_NAME}, you received a message lasting
\${VM_DUR} at \${VM_DATE} from, (\${VM_CALLERID}). This is
message \${VM_MSGNUM} in your voicemail Inbox.

Cancel
Load Default Settings
Save

Figure 59: Voicemail Email Settings

Table 42: Voicemail Email Settings

Attach Recordings to E-Mail	If enabled, voicemails will be sent to user's Email address. The default setting is "Yes".
Template For Voicemail Emails	<p>Fill in the "Subject:" and "Message:" content, to be used in the Email when sending to the user.</p> <p>The template variables are:</p> <ul style="list-style-type: none"> \t: TAB \${VM_NAME}: Recipient's first name and last name \${VM_DUR}: The duration of the voicemail message \${VM_MAILBOX}: The recipient's extension \${VM_CALLERID}: The caller ID of the person who has left the message \${VM_MSGNUM}: The number of messages in the mailbox \${VM_DATE}: The date and time when the message is left

Click on "Load Default Settings" button to view the default template as an example.

CONFIGURE VOICEMAIL GROUP

The UCM6510 supports voicemail group and all the extensions added in the group will receive the voicemail to the group extension. The voicemail group can be configured under web GUI->**PBX->Call Features->Voicemail Group**. Click on "Create New Voicemail Group" to configure the group.

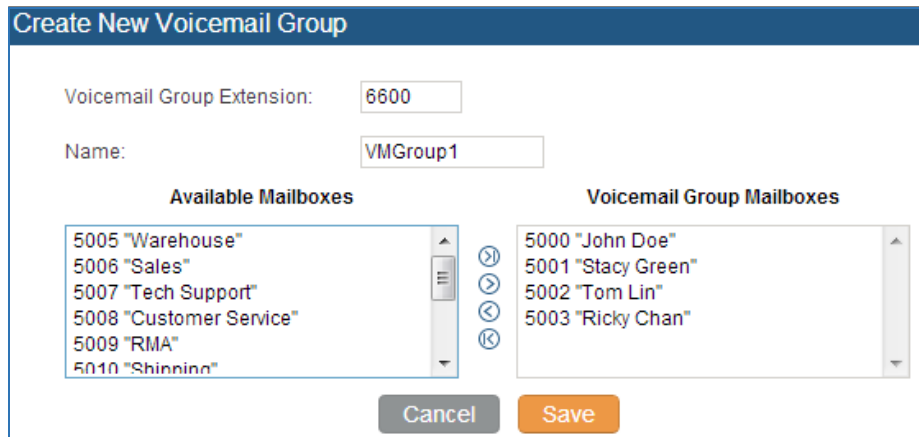

Figure 60: Voicemail Group

Table 43: Voicemail Group Settings

Voicemail Group Extension	Enter the Voicemail Group Extension. The voicemail messages left to this extension will be forwarded to all the voicemail group members.
Name	Configure the Name to identify the voicemail group. Letters, digits, _ and - are allowed.
Voicemail Group Mailboxes	Select available mailboxes from the left list and add them to the right list. The extensions need to have voicemail enabled to be listed in available mailboxes list.

This page intentionally left blank

RING GROUP

The UCM6510 supports ring group feature with different ring strategies applied to the ring group members. This section describes the ring group configuration on the UCM6510.

CONFIGURE RING GROUP

Ring group settings can be accessed via web GUI->**PBX->Call Features->Ring Group**.

Create New Ring Group			
Extension	Ring Group Name	Members	Options
6400	techsupport	6005, 6006, 6007	 

Figure 61: Ring Group







- Click on "Create New Ring Group" to add ring group.
- Click on  to edit the ring group. The following table shows the ring group configuration parameters.
- Click on  to delete the ring group.

Table 44: Ring Group Parameters

Ring Group Name	Configure ring group name to identify the ring group. Letters, digits, _ and - are allowed.
Extension	Configure the ring group extension.
Ring Group Members	Select available users from the left side to the ring group member list on the right side. Click on     to arrange the order.
Ring Strategy	Select the ring strategy. The default setting is "Ring in order". <ul style="list-style-type: none"> • Ring simultaneously Ring all the members at the same time when there is incoming call to the ring group extension. If any of the member answers the call, it will stop ringing. • Ring in order Ring the members with the order configured in ring group list. If the first member doesn't answer the call, it will stop ringing the first member and start ringing the second member.
Ring Timeout on Each Member	Configure the number of seconds to ring each member. If set to 0, it will keep ringing. The default setting is 30 seconds. Note:

	The actual ring timeout might be overridden by users if the phone has ring timeout settings as well.
Enable Destination	If enabled, users could select extension, voicemail, ring group, IVR, call queue, voicemail group as the destination if the call to the ring group has no answer. Secret and Email address are required if voicemail is selected as the destination.
Secret	Configure the password to access the ring group extension's voicemail. Note: The password has to be at least 4 characters.
Email Address	Configure the Email address of the ring group extension's voicemail. If "Attach Recordings to E-mail" is enabled from web GUI-> PBX->Voicemail->Voicemail Email Settings , the voicemail can be sent to the ring group's Email address as attachment.

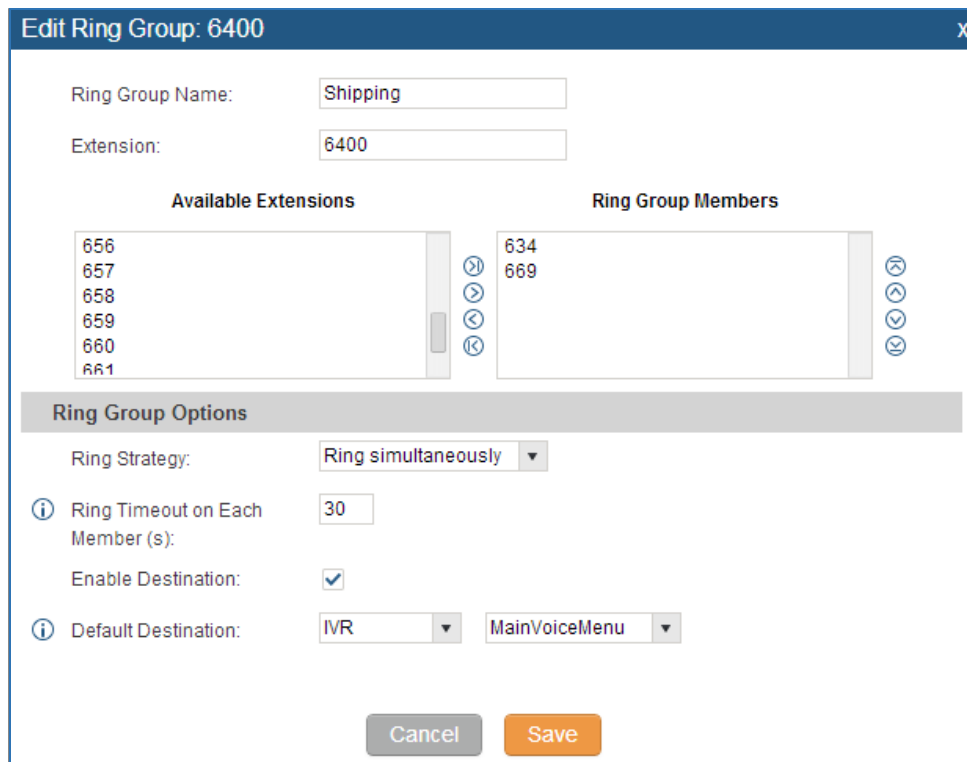

Edit Ring Group: 6400

Ring Group Name:

Extension:

Available Extensions

- 656
- 657
- 658
- 659
- 660
- 661

Ring Group Members

- 634
- 669

Ring Group Options

Ring Strategy:

Ring Timeout on Each Member (s):

Enable Destination:

Default Destination:

Figure 62: Ring Group Configuration

PAGING AND INTERCOM GROUP

The UCM6510 paging and intercom can be used via feature code to a single extension or a paging/intercom group. This sections describes the configuration of paging/intercom group under web GUI->PBX->Call Features->Paging/Intercom.

CONFIGURE PAGING/INTERCOM GROUP

- Click on "Create New Paging/Intercom Group" to add paging/intercom group.

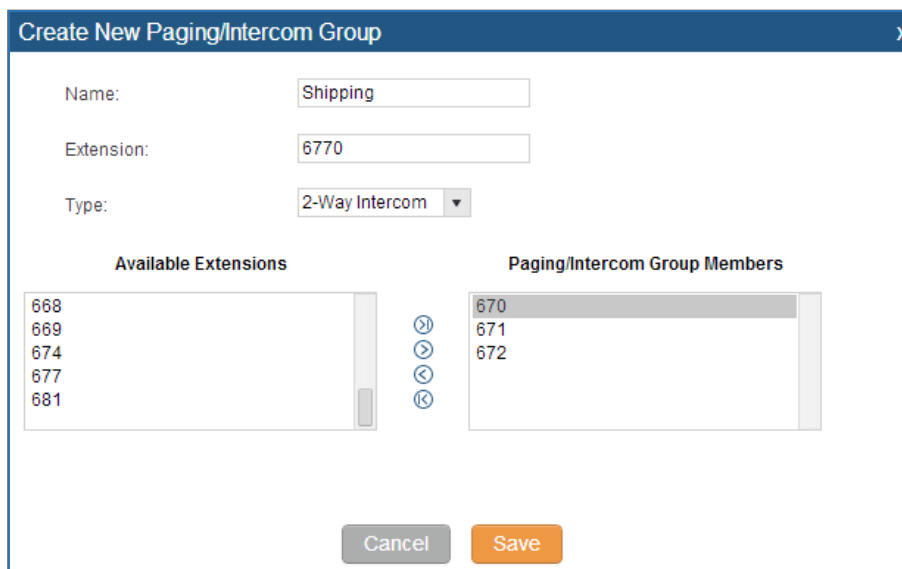



Figure 63: Paging/Intercom Group

Table 45: Paging/Intercom Group Configuration Parameters

Name	Configure paging/intercom group name.
Extension	Configure the paging/intercom group extension.
Type	Select "2-way Intercom" or "1-way Page".
Page/Intercom Group Members	Select available users from the left side to the paging/intercom group member list on the right.

- Click on  to edit the paging/intercom group.

- Click on  to delete the paging/intercom group.
- Click on "Paging/Intercom Group Settings" to edit Alert-Info Header. This header will be included in the SIP INVITE message sent to the callee in paging/intercom call.

Feature Codes Configure the paging/intercom feature code.' At the bottom are 'Cancel' and 'Save' buttons." data-bbox="203 225 786 385"/>

Figure 64: Page/Intercom Group Settings

- The UCM6510 has pre-configured paging/intercom feature code. By default, the Paging Prefix is *81 and the Intercom Prefix is *80. To edit page/intercom feature code, click on "Feature Codes" in the "Paging/Intercom Group Settings" dialog. Or users could go to web GUI->**PBX**->**Internal Options**->**Feature Codes** directly.

CALL QUEUE

The UCM6510 supports call queue by using static agents or dynamic agents. This sections describes the configuration of call queue under web GUI->**PBX->Call Features->Call Queue**.

CONFIGURE CALL QUEUE

Call queue settings can be accessed via web GUI->**PBX->Call Features->Call Queue**.

- Click on "Create New Queue" to add call queue.









Create New Queue		Agent Login Settings	
Call Queue	Name	Strategy	Options
6500	TechSupport1	Linear	 
6501	Warehouse	Ringall	 
6502	Sales	Ringall	 
6503	TechSupport2	Least Recent	 

Figure 65: Call Queue







- Click on  to edit the call queue. The call queue configuration parameters are listed in the table below.

Table 46: Call Queue Configuration Parameters

Extension	Configure the call queue extension.
Name	Configure the call queue name to identify the call queue.
Strategy	<p>Select the strategy for the call queue.</p> <ul style="list-style-type: none"> • Ring All Ring all available Agents simultaneously until one answers. • Linear Ring agents in the specified order. • Least Recent Ring the agent who has been called the least recently. • Fewest Calls Ring the agent with the fewest completed calls. • Random Ring a random agent. • Round Robin Ring the agents in Round Robin scheduling with memory.

	The default setting is "Ring All".
Music On Hold	<p>Select the Music On Hold class for the call queue.</p> <p>Note: Music On Hold classes can be managed from web GUI-> PBX->Internal Options->Music On Hold.</p>
Leave When Empty	<p>Configure whether the callers will be disconnected from the queue or not if the queue has no agent anymore. The default setting is "Strict".</p> <ul style="list-style-type: none"> • Yes Callers will be disconnected from the queue if all agents are paused or invalid. • No Never disconnect the callers from the queue when the queue is empty. • Strict Callers will be disconnected from the queue if all agents are paused, invalid or unavailable.
Dial in Empty Queue	<p>Configure whether the callers can dial into a call queue if the queue has no agent. The default setting is "No".</p> <ul style="list-style-type: none"> • Yes Callers can always dial into a call queue. • No Callers cannot dial into a queue if all agents are paused or invalid. • Strict Callers cannot dial into a queue if the agents are paused, invalid or unavailable.
Dynamic Login Password	If enabled, the configured PIN number is required for dynamic agent to log in. The default setting is disabled.
Ring Time Out	Configure the number of seconds an agent will ring before the call goes to the next agent. The default setting is 15 seconds.
Wrapup Time	Configure the number of seconds before a new call can ring the queue after the last call on the agent is completed. If set to 0, there will be no delay between calls to the queue. The default setting is 15 seconds.
Max Queue Length	Configure the maximum number of calls to be queued at once. This number does not include calls that have been connected with agents. It only includes calls not connected yet. The default setting is 0, which means unlimited. When the maximum value is reached, the caller will be treated with busy tone followed by the next calling rule after attempting to enter the queue.

Report Hold Time	If enabled, the UCM6510 will report (to the agent) the duration of time of the call before the caller is connected to the agent. The default setting is "No".
Wait Time	If enabled, users will be disconnected after the configured number of seconds. The default setting is "No". Note: It is recommended to configure "Wait Time" longer than the "Wrapup Time".
Agents	Select the available users to be the static agents in the call queue. Choose from the available users on the left to the static agents list on the right. Click on     to arrange the order.

- Click on  to delete the call queue.
- Click on "Agent Login Settings" to configure Agent Login Extension Postfix and Agent Logout Extension Postfix. Once configured, users could log in the call queue as dynamic agent.

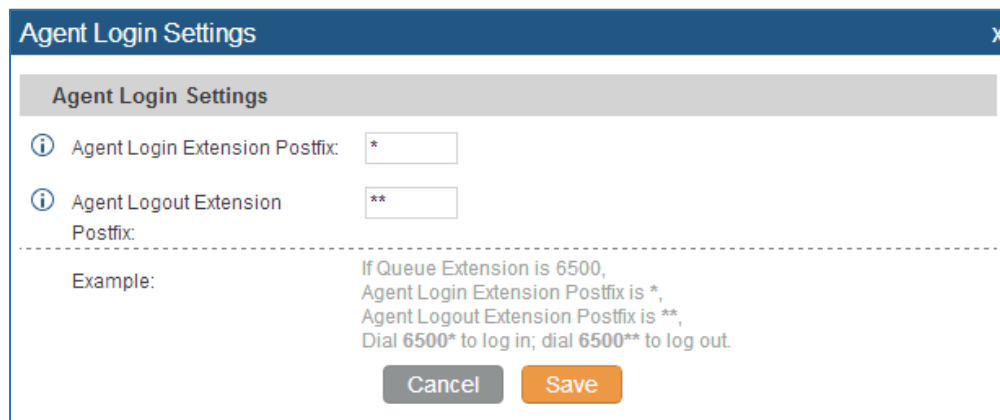

The image shows a dialog box titled "Agent Login Settings" with a close button (X) in the top right corner. The dialog has a header "Agent Login Settings" and two input fields: "Agent Login Extension Postfix:" with a single asterisk (*) and "Agent Logout Extension Postfix:" with two asterisks (**). Below these fields is a dashed line and an "Example:" section. The example text reads: "If Queue Extension is 6500, Agent Login Extension Postfix is *, Agent Logout Extension Postfix is **, Dial 6500* to log in; dial 6500** to log out." At the bottom of the dialog are two buttons: "Cancel" and "Save".

Figure 66: Agent Login Settings

For example, if the call queue extension is 6500, Agent Login Extension Postfix is * and Agent Logout Extension Postfix is **, users could dial 6500* to login to the call queue as dynamic agent and dial 6500** to logout from the call queue. Dynamic agent doesn't need to be listed as static agent and can log in/logout at any time.

- Call queue feature code "Agent Pause" and "Agent Unpause" can be configured under web GUI->PBX->Internal Options->Feature Codes. The default feature code is *83 for "Agent Pause" and *84 for "Agent Unpause".

This page intentionally left blank

EXTENSION GROUPS

The UCM6510 extension group feature allows users to assign extensions to different groups to better manage the configurations on the PBX. For example, when configuring "Enable Filter on Source Caller ID", users could select a group instead of each person's extension to assign. This feature simplifies the configuration process and helps manage and categorize the extensions for business environment.

CONFIGURE EXTENSION GROUPS

Extension group can be configured via web GUI->**PBX->Call Features->Extension Groups**.

- Click on "Create New Extension Group" to create a new extension group.
- Click on  to edit the extension group.

Select extensions from the list on the left side to the right side.

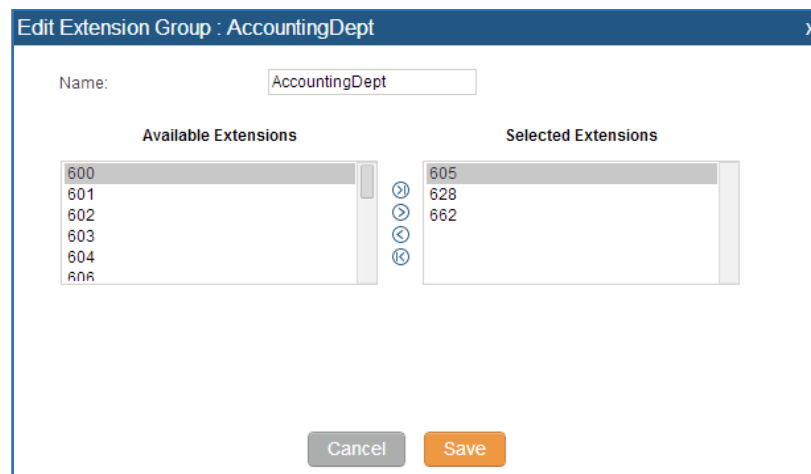

Figure 67: Edit Extension Group

- Click on  to delete the extension group.

USE EXTENSION GROUPS

Here is an example where the extension group can be used. Go to web GUI->**PBX->Basic/Call Routes->Outbound Routes** and select "Enable Filter on Source Caller ID". Both single extensions and extension groups will show up for users to select.

Edit Outbound Rule: usa1

(i) Calling Rule Name:

(i) Pattern: +

(i) Password:

(i) Privilege Level: ▼

(i) Enable Filter on Source Caller ID:

Available Extensions/Extension Groups		Selected Extensions/Extension Groups
Extension Group -- Accounting_Dept	➤ ➤ ➤ ➤ ➤	
Extension Group -- Marketing_Dept		
Extension Group -- IT_Dept		
Extension Group -- Sales_Dept		
Extension Group -- TechSupport_Dept		

(i) Custom Dynamic Route:

Figure 68: Select Extension Group in Outbound Route

PICKUP GROUPS

The UCM6510 supports pickup group feature which allows users to pick up incoming calls for other extensions if they are in the same pickup group, by dialing "Pickup Extension" feature code (by default *8).

CONFIGURE PICKUP GROUPS

Pickup groups can be configured via web GUI->**PBX**->**Call Features**->**Pickup Groups**.

- Click on "Create New Pickup Group" to create a new pickup group.
- Click on  to edit the pickup group.

Select extensions from the list on the left side to the right side.

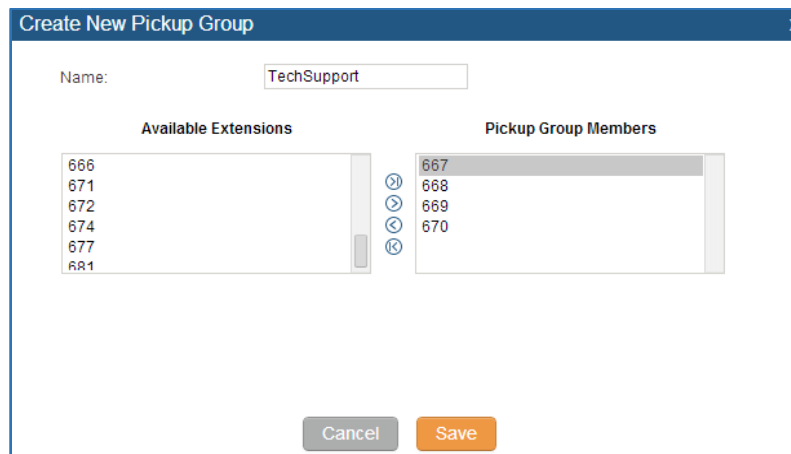

Figure 69: Edit Pickup Group

- Click on  to delete the pickup group.

This page intentionally left blank

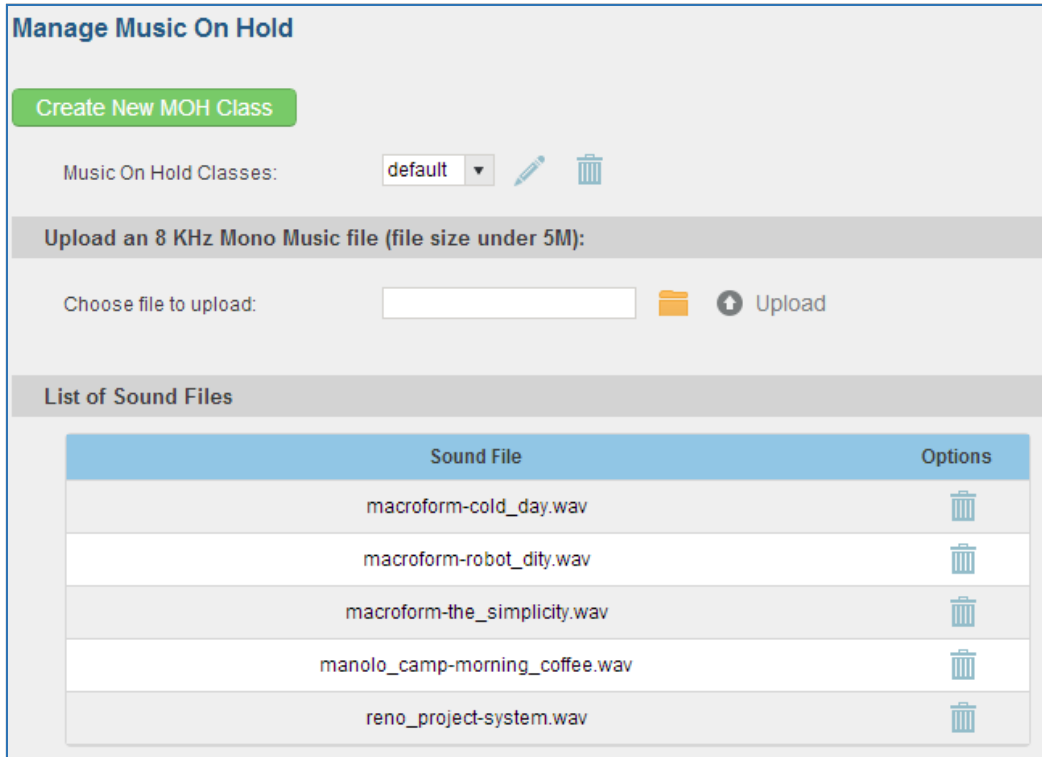

MUSIC ON HOLD

Music On Hold settings can be accessed via web GUI->**PBX->Internal Options->Music On Hold**. In this page, users could configure music on hold class and upload music files. The "default" Music On Hold class already has 5 audio files defined for users to use.





Manage Music On Hold

Create New MOH Class

Music On Hold Classes: default  

Upload an 8 KHz Mono Music file (file size under 5M):

Choose file to upload:   Upload

List of Sound Files











Sound File	Options
macroform-cold_day.wav	
macroform-robot_dity.wav	
macroform-the_simplicity.wav	
manolo_camp-morning_coffee.wav	
reno_project-system.wav	

Figure 70: Music On Hold Default Class

- Click on "Create New MOH Class" to add a new Music On Hold class.
- Click on  to configure the MOH class sort method to be "Alpha" or "Random" for the sound files.
- Click on  next to the selected Music On Hold class to delete this Music On Hold class.
- Click on  to select music file from local PC and click on  to start uploading. The music file uploaded has to be 16 bit, 8 KHz Mono in .wav format with size smaller than 5M.
- Click on  next to the sound file to delete it from the selected Music On Hold Class.

 **Note:**

In case the users have deleted the system MOH files, there are two ways to recover.

1. Users could download the MOH file from this link:

<http://downloads.asterisk.org/pub/telephony/sounds/releases/asterisk-moh-opsound-wav-2.03.tar.gz>

After downloading, unzip the pack and upload the music files to the UCM6510.

2. Factory reset could also recover the MOH file on the UCM.
-

FAX/T.38



The UCM6510 supports T.30/T.38 Fax and Fax Pass-through. It can also convert the received Fax to PDF format and send it to the configured Email address. Fax/T.38 settings can be accessed via web GUI->**PBX->Internal Options->FAX/T.38.**

CONFIGURE FAX/T.38

- Click on "Create New Fax Extension". In the popped up window, fill the extension, name and Email address to send the received Fax to.
- Click on "Fax Settings" to configure the Fax parameters.

Table 47: FAX/T.38 Settings

Enable Error Correction Mode	Configure to enable Error Correction Mode (ECM) for the Fax. The default setting is "Yes".
Maximum Transfer Rate	Configure the maximum transfer rate during the Fax rate negotiation. The possible values are 2400, 4800, 7200, 9600, 12000 and 14400. The default setting is 14400.
Minimum Transfer Rate	Configure the minimum transfer rate during the Fax rate negotiation. The possible values are 2400, 4800, 7200, 9600, 12000 and 14000. The default setting is 2400.
Default Email Address	Configure the Email address to send the received Fax to if user's Email address cannot be found. Note: The extension's Email address or the Fax's default Email address needs to be configured in order to receive Fax from Email. If neither of them is configured, Fax will be not be received from Email.
Template Variables	Fill in the "Subject:" and "Message:" content, to be used in the Email when sending the Fax to the users. The template variables are: <ul style="list-style-type: none"> • <code>{CALLERIDNUM}</code> : Caller ID Number • <code>{CALLERIDNAME}</code> : Caller ID Name • <code>{RECEIVEEXTEN}</code> : The extension to receive the Fax • <code>{FAXPAGES}</code> : Number of pages in the Fax • <code>{VM_DATE}</code> : The date and time when the Fax is received

- Click on  to edit the Fax extension.
- Click on  to delete the Fax extension.

SAMPLE CONFIGURATION TO RECEIVE FAX FROM PSTN LINE

The following instructions describes how to use the UCM6510 to receive Fax from PSTN line on the Fax machine connected to the UCM6510 FXS port.

1. Connect Fax machine to the UCM6510 FXS port.
2. Connect PSTN line to the UCM6510 FXO port.
3. Go to web GUI->**PBX**->**Analog Trunks** page.
4. Create or edit the analog trunk for Fax as below.

Fax Detection: Make sure "Fax Detection" option is set to "No".

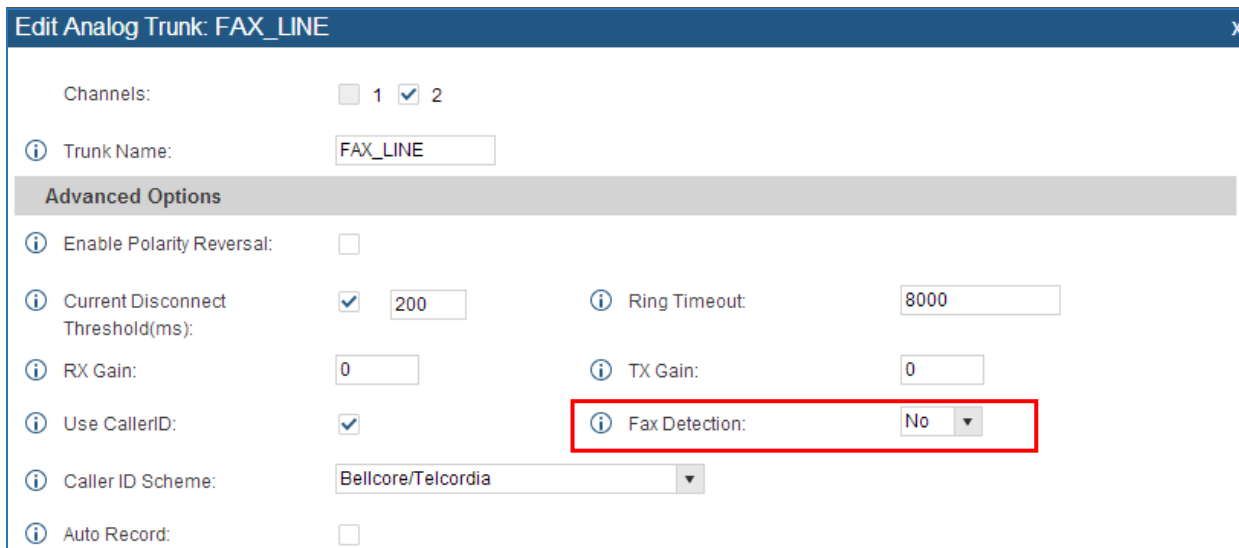

The screenshot shows the configuration page for an analog trunk named 'FAX_LINE'. The 'Channels' section has checkboxes for 1 and 2, with 2 selected. The 'Trunk Name' is 'FAX_LINE'. Under 'Advanced Options', several settings are visible: 'Enable Polarity Reversal' is unchecked; 'Current Disconnect Threshold(ms)' is checked and set to 200; 'Ring Timeout' is set to 8000; 'RX Gain' is set to 0; 'TX Gain' is set to 0; 'Use CallerID' is checked; 'Caller ID Scheme' is set to 'Bellcore/Telcordia'; and 'Auto Record' is unchecked. The 'Fax Detection' dropdown menu is highlighted with a red box and is set to 'No'.

Figure 71: Configure Analog Trunk without Fax Detection

5. Go to UCM6510 web GUI->**PBX**->**Basic/Call Routes**->**Extensions** page.
6. Create or edit the extension for FXS port.
 - **Analog Station:** Select FXS port to be assigned to the extension. By default, it's set to "None".
 - Once selected, analog related settings for this extension will show up in "**Analog Settings**" section.

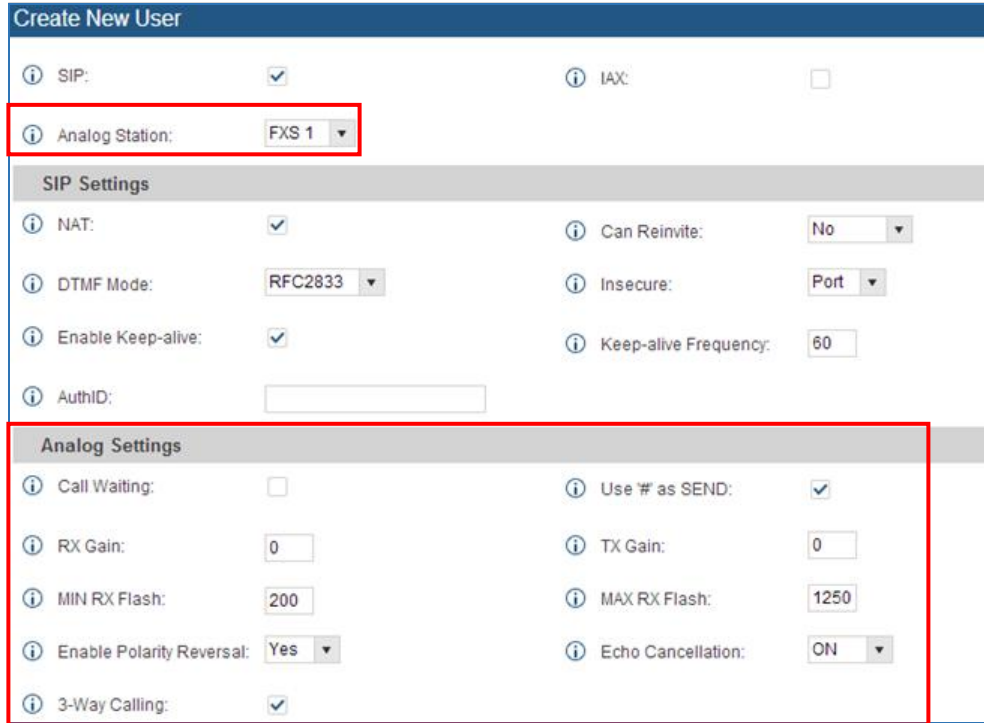

Create New User

SIP: IAX:

Analog Station: **FXS 1**

SIP Settings

NAT: Can Reinvite: No

DTMF Mode: RFC2833 Insecure: Port

Enable Keep-alive: Keep-alive Frequency: 60

AuthID:

Analog Settings

Call Waiting: Use # as SEND:

RX Gain: 0 TX Gain: 0

MIN RX Flash: 200 MAX RX Flash: 1250

Enable Polarity Reversal: Yes Echo Cancellation: ON

3-Way Calling:

Figure 72: Configure Extension For Fax Machine

7. Go to web GUI->PBX->Basic/Call Routes->Inbound Routes page.
8. Create an inbound route to use the Fax analog trunk. Select the created extension for Fax machine in step 4 as the default destination.

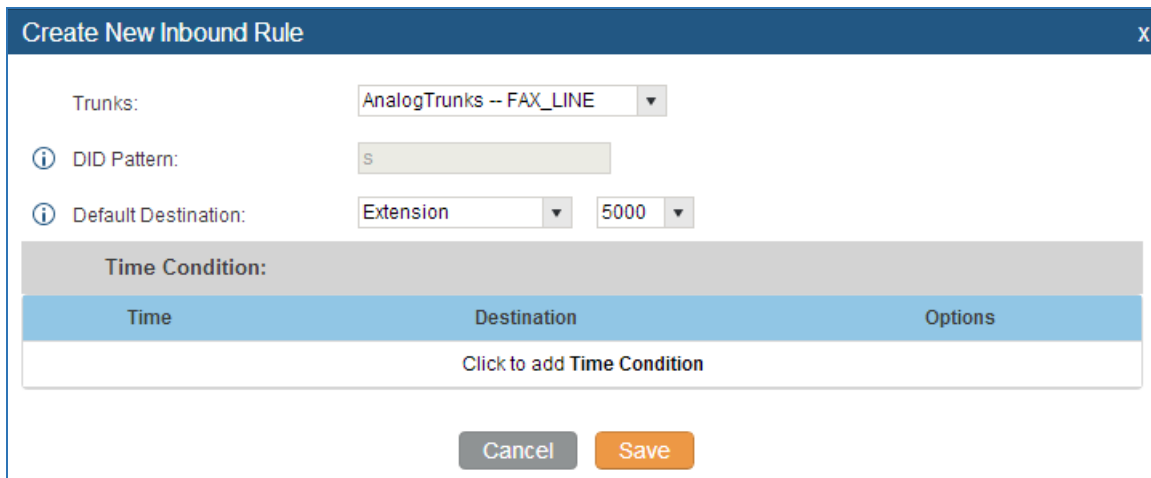

Create New Inbound Rule

Trunks: AnalogTrunks -- FAX_LINE

DID Pattern: s

Default Destination: Extension 5000

Time Condition:

Time	Destination	Options
Click to add Time Condition		

Cancel Save

Figure 73: Configure Inbound Rule for Fax

Now the Fax configuration is done. When there is an incoming Fax calling to the PSTN number for the FXO port, it will send the Fax to the Fax machine.

SAMPLE CONFIGURATION FOR FAX-TO-EMAIL

The following instructions describes a sample configuration on how to use Fax-to-Email feature on the UCM6510.

1. Connect PSTN line to the UCM6510 FXO port.
2. Go to UCM6510 web GUI->**Internal Options**->**Fax/T.38** page. Create a new Fax extension.

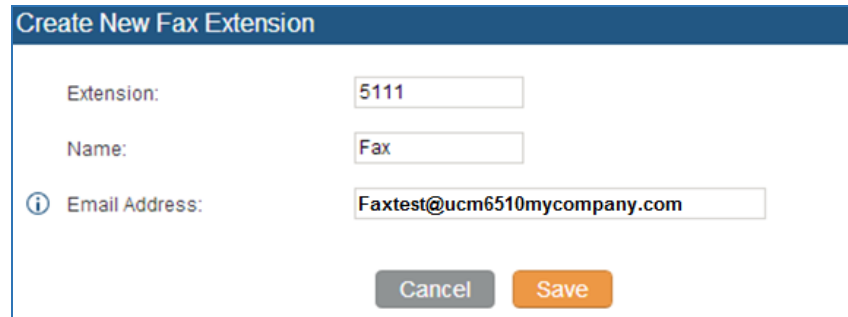

Create New Fax Extension

Extension:

Name:

📘 Email Address:

Figure 74: Create Fax Extension

3. Go to UCM6510 web GUI->**Basic/Call Routes**->**Analog Trunks** page. Create a new analog trunk with "FAX Detection" set to "No".
4. Go to UCM6510 web GUI->**Basic/Call Routes**->**Inbound Routes** page. Create a new inbound route and set the default destination to the Fax extension.

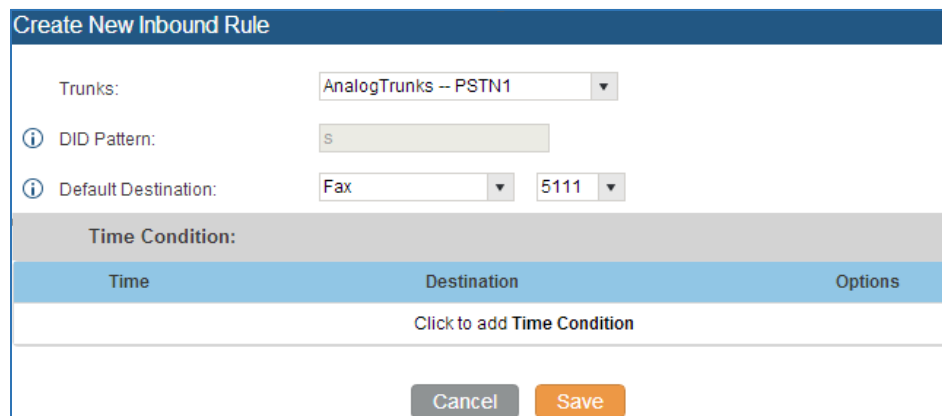

Create New Inbound Rule

Trunks:

📘 DID Pattern:

📘 Default Destination:

Time Condition:



Time	Destination	Options
Click to add Time Condition		

Figure 75: Inbound Route to Fax Extension

5. Once successfully configured, the incoming Fax from external Fax machine to the PSTN line number will be converted to PDF file and sent to the Email address **Faxtest@ucm6510mycompany.com** as attachment.

DISA

The UCM6510 supports DISA to be used in IVR or inbound route. Before using it, create new DISA under web GUI->**Call Features->DISA**.

- Click on "Create New DISA" to add a new DISA.
- Click on  to edit the DISA configuration.
- Click on  to delete the DISA.

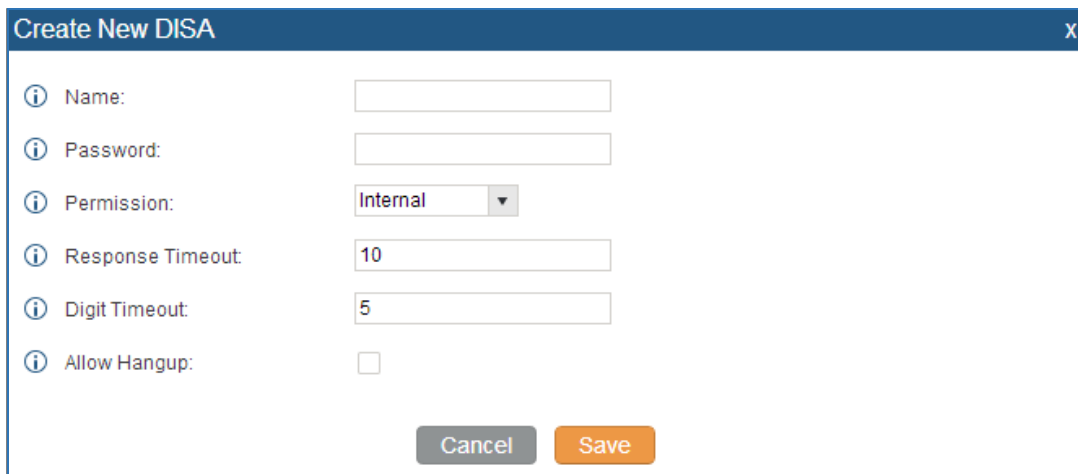

Figure 76: Create New DISA

Table 48: DISA Settings

Name	Configure DISA name to identify the DISA.
Password	Configure the password (digit only) required for the user to enter before using DISA to dial out. Note: The password has to be at least 4 digits.
Permission	Configure the permission level for DISA. The available permissions are "Internal", "Local", "National" and "International" from the lowest level to the highest level. The default setting is "Internal". If the user tries to dial outbound calls after dialing into the DISA, the UCM6510 will compare the DISA's permission level with the outbound route's privilege level. If the DISA's permission level is higher than (or equal to) the outbound

	route's privilege level, the call will be allowed to go through.
Response Timeout	Configure the maximum amount of time the UCM6510 will wait before hanging up if the user dials an incomplete or invalid number. The default setting is 10 seconds.
Digit Timeout	Configure the maximum amount of time permitted between digits when the user is typing the extension. The default setting is 5 seconds.
Allow Hangup	If enabled, during an active call, users can enter the UCM6510 hangup feature code (*0 by default) to disconnect the call or hang up directly. A new dial tone will be heard shortly for the user to make a new call. The default setting is "No".

Once successfully created, users can configure the inbound route destination as "DISA" or IVR key event as "DISA". When dialing into DISA, users will be prompted with password first. After entering the correct password, a second dial tone will be heard for the users to dial out.

BLF AND EVENT LIST

BLF

The UCM6510 supports BLF monitoring for extensions, ring group, call queue, conference room and parking lot. For example, on the user's phone, configure the parking lot number 701 as the BLF monitored number. When there is a parked call on 701, the LED for this BLF key will light up in red, meaning a call is parked against this parking lot. Pressing this BLF key can pick up the call from this parking lot.





Note:

- On the Grandstream GXP phones, the MPK supports "Call Park" mode, which is normally used to park the call by configuring the MPK number as call park feature code (e.g., 700). Users could also use "Call Park" mode to monitor and pick up the call on this parking lot by configuring the MPK number as parking lot number (e.g., 701).
-

EVENT LIST

Besides BLF, users can also configure the phones to monitor event list. By using event list, local extensions on the same UCM6510 or remote extensions on the VOIP trunk can be monitored. The event list settings is under web GUI->**Call Features**->**Event List**.

- Click on "Create New Event List" to add a new event list.
- Click on  to edit the event list configuration.
- Click on  to delete the event list.

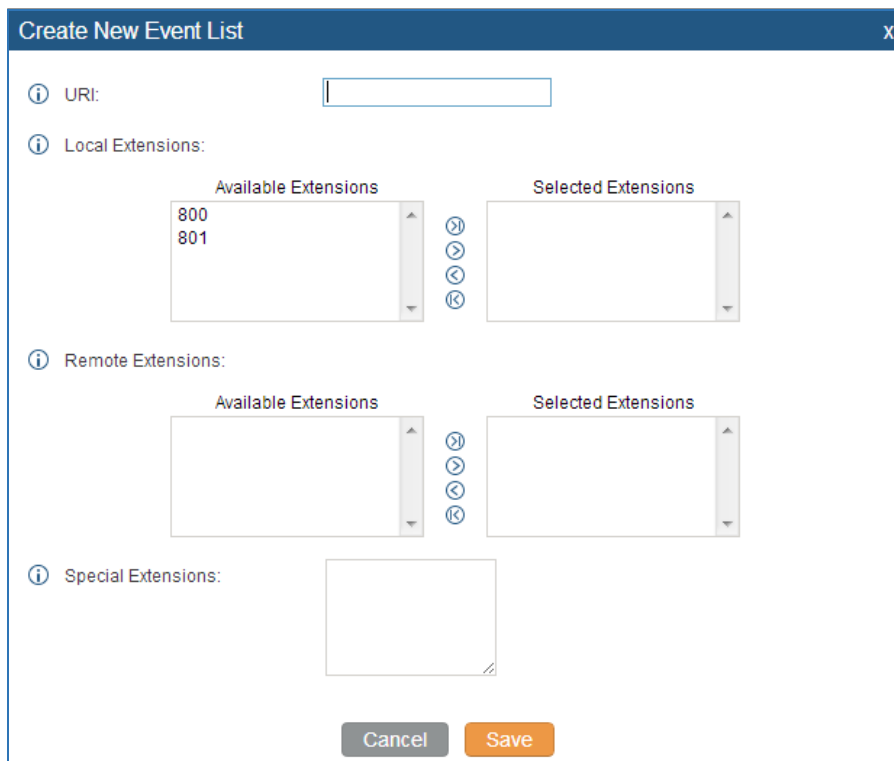

Figure 77: Create New Event List

Table 49: Event List Settings

URI	Configure the name of this event list (for example, office_event_list). Please note the URI name cannot be the same as the extension name on the UCM6510. The valid characters are letters, digits, _ and -.
Local Extensions	Select the available extensions listed on the local UCM6510 to be monitored in the event list.
Remote Extensions	If LDAP sync is enabled between the UCM6510 and the peer UCM6510, the remote extensions will be listed under "Available Extensions". If not, manually enter the remote extensions under "Special Extensions" field.
Special Extensions	Manually enter the remote extensions in the peer/register trunk to be monitored in the event list. Valid format: 5000,5001,9000

Remote extension monitoring works on the UCM6510 via event list BLF, among Peer SIP trunks or Register SIP trunks (register to each other). Therefore, please properly configure SIP trunks on the

UCM6510 first before using remote BLF feature. Please note the SIP end points need support event list BLF in order to monitor remote extensions.

When an event list is created on the UCM6510 and remote extensions are added to the list, the UCM6510 will send out SIP SUBSCRIBE to the remote UCM6510 to obtain the remote extension status. When the SIP end points registers and subscribes to the local UCM6510 event list, it can obtain the remote extension status from this event list.

Once successfully configured, the event list page will show the status of total extension and subscribers for each event list. Users can also select the event URI to check the monitored extension's status and the subscribers' details.



Note:

- To configure LDAP sync, please go to UCM6510 web GUI->**PBX->Basic/Call Routes->VoIP Trunk**. You will see "Sync LDAP Enable" option. Once enabled, please configure password information for the remote peer UCM6510 to connect to the local UCM6510. Additional information such as port number, LDAP outbound rule, LDAP Dialed Prefix will also be required. Both the local UCM6510 and remote UCM6510 need enable LDAP sync option with the same password for successful connection and synchronization.
 - Currently LDAP sync feature only works between two UCM6510s.
 - (Theoretically) Remote BLF monitoring will work when the remote PBX being monitored is non-UCM6510 PBX. However, it might not work the other way around depending on whether the non-UCM6510 PBX supports event list BLF or remote monitoring feature.
-

This page intentionally left blank

DIAL BY NAME

Dial By Name is a feature on the PBX that allows caller to search a person by first or last name via his/her phone's keypad. The administrator can define the Dial By Name directory including the desired extensions in the directory and the searching type by "first name" or "last name". After dialing in, the PBX IVR/Auto Attendant will guide the caller to spell the digits to find the person in the Dial By Name directory. This feature allows customers/clients to use the guided automatic system to get in touch with the enterprise employees without having to know the extension number, which brings convenience and improves business image for the enterprise.

DIAL BY NAME CONFIGURATION

The administrators can create the dial by name group under web GUI->**PBX->Call Features->Dial By Name**.

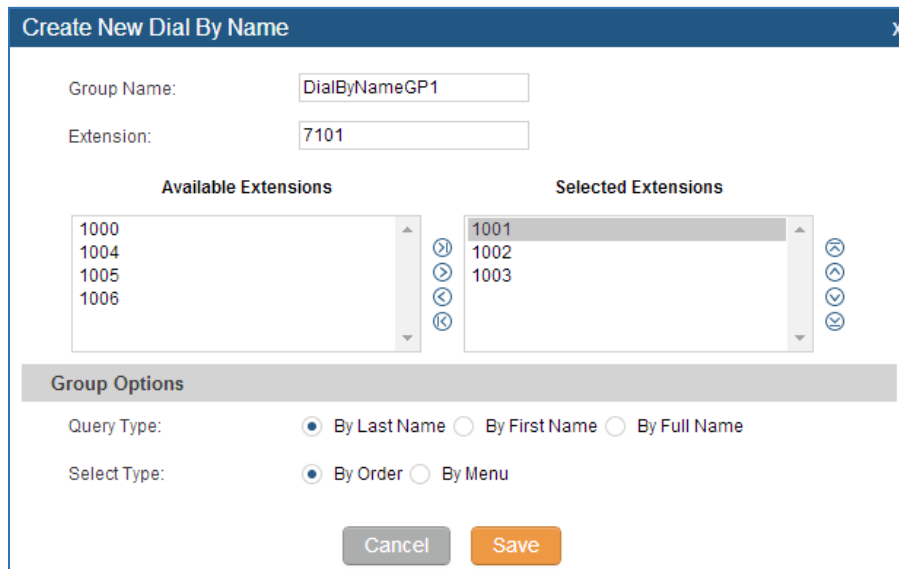

Figure 78: Create Dial By Name Group

1. Group Name

Enter the Group Name. This is to identify the Dial By Name group. The Dial By Name group can be used as the destination for inbound route and key pressing event for IVR. The group name defined here will show up in the destination list when configuring IVR and inbound route.

Create New IVR

ⓘ Name:
 ⓘ Extension:
 ⓘ Dial Other Extensions:
 ⓘ Dial Trunk:
 ⓘ Permission:
 ⓘ Welcome Prompt: [Prompt](#)
 ⓘ Digit Timeout:
 ⓘ Response Timeout:
 ⓘ Response Timeout Prompt:
 ⓘ Invalid Prompt:
 ⓘ Response Timeout Repeat Loops:
 ⓘ Invalid Repeat Loops:
 ⓘ Language:

Key Pressing Events

Press 0:
 Press 1:
 Press 2:

Figure 79: Dial By Name Group In IVR Key Pressing Events

Create New Inbound Rule

Trunks:
 ⓘ DID Pattern: /
 ⓘ Privilege Level:
 ⓘ Default Destination:
 ⓘ Dial Trunk:

Time Condition:

Time	Destination	Options
Click to add Time Condition		

Figure 80: Dial By Name Group In Inbound Route

2. Extension

Configure the direct dial extension for the Dial By Name group.

3. Available Extensions/Selected Extensions

Select available extensions from the left side to the right side as the directory for the Dial By Name group. Only the selected extensions here can be reached by the Dial By Name IVR when dialing into this group. The extensions here must have valid first name and last name configured under web GUI->**PBX->Basic/Call Routes->Extensions** in order to be searchable in Dial By Name directory through IVR. By specifying the extensions here, the administrators can make sure unscreened calls will not reach the company employee if he/she doesn't want to receive them directly.

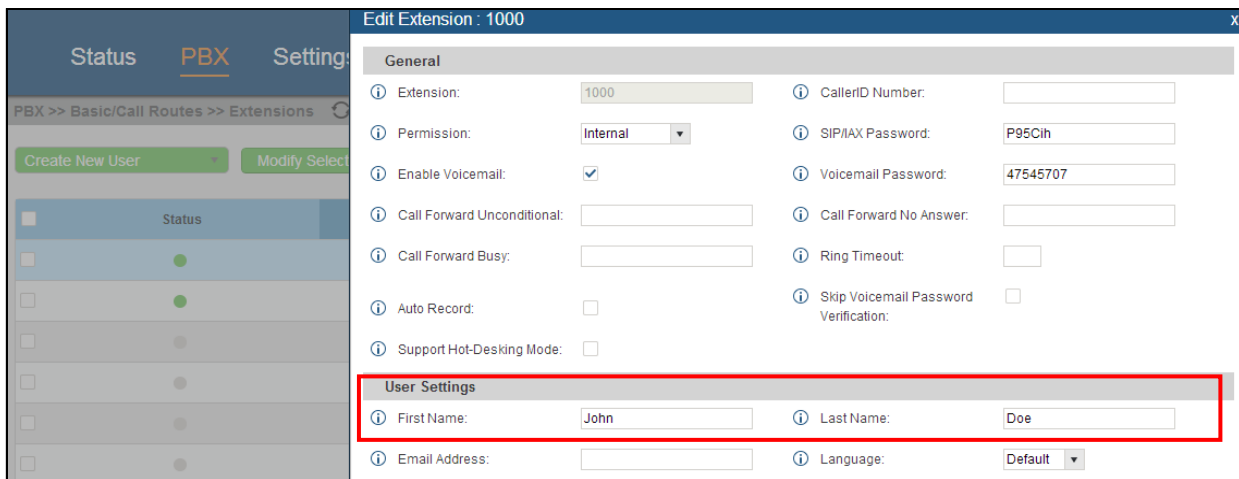

The screenshot shows the 'Edit Extension : 1000' configuration page. The 'User Settings' section is highlighted with a red box and contains the following fields:

- First Name: John
- Last Name: Doe
- Email Address: (empty)
- Language: Default

Figure 81: Configure Extension First Name And Last Name

4. Query Type

Specify the query type. This defines how the caller will need to enter to search the directory.

By First Name: enter the first 3 digits of the first name to search the directory.

By Last Name: enter the first 3 digits of the last name to search the directory.

By Full Name: enter the first 3 digits of the first name or last name to search the directory.

5. Select Type

Specify the select type on the searching result. The IVR will confirm the name/number for the party the caller would like to reach before dialing out

By Order: After the caller enters the digits, the IVR will announce the first matching party's name and number. The caller can confirm and dial out if it's the destination party, or press * to listen to the next matching result if it's not the desired party to call.

By Menu: After the caller enters the digits, the IVR will announce 8 matching results. The caller can press number 1 to 8 to select and call, or press 9 for results in next page.

This page intentionally left blank

CALL FEATURES

The UCM6510 supports call recording, transfer, call forward, call park and other call features via feature code. This section lists all the feature codes in the UCM6510 and describes how to use the call features.

FEATURE CODES

Table 50: UCM6510 Feature Codes

Feature Maps	
Blind Transfer	<ul style="list-style-type: none"> • Default code: #1. • Enter the code during active call. After hearing "Transfer", you will hear dial tone. Enter the number to transfer to. Then the user will be disconnected and transfer is completed. • Options <ul style="list-style-type: none"> Disable Allow Caller: Enable the feature code on caller side only. Allow Callee: Enable the feature code on callee side only. Allow Both: Enable the feature code on both caller and callee.
Attended Transfer	<ul style="list-style-type: none"> • Default code: *2. • Enter the code during active call. After hearing "Transfer", you will hear the dial tone. Enter the number to transfer to and the user will be connected to this number. Hang up the call to complete the attended transfer. • Options <ul style="list-style-type: none"> Disable Allow Caller: Enable the feature code on caller side only. Allow Callee: Enable the feature code on callee side only. Allow Both: Enable the feature code on both caller and callee.
Disconnect	<ul style="list-style-type: none"> • Default code: *0. • Enter the code during active call. It will disconnect the call. • Options <ul style="list-style-type: none"> Disable Allow Caller: Enable the feature code on caller side only. Allow Callee: Enable the feature code on callee side only. Allow Both: Enable the feature code on both caller and callee.
Call Park	<ul style="list-style-type: none"> • Default code: #72. • Enter the code during active call to park the call.



	<ul style="list-style-type: none"> Options Disable Allow Caller: Enable the feature code on caller side only. Allow Callee: Enable the feature code on callee side only. Allow Both: Enable the feature code on both caller and callee.
Audio Mix Record	<ul style="list-style-type: none"> Default code: *3. Enter the code followed by # or SEND to start recording the audio call and the UCM6510 will mix the streams natively on the fly as the call is in progress. Options Disable Allow Caller: Enable the feature code on caller side only. Allow Callee: Enable the feature code on callee side only. Allow Both: Enable the feature code on both caller and callee.
DND/Call Forward	
Do Not Disturb (DND) Activate	<ul style="list-style-type: none"> Default code: *77.
Do Not Disturb (DND) Deactivate	<ul style="list-style-type: none"> Default code: *78.
Call Forward Busy Activate	<ul style="list-style-type: none"> Default Code: *90. Enter the code and follow the voice prompt. Or enter the code followed by the extension to forward the call.
Call Forward Busy Deactivate	<ul style="list-style-type: none"> Default Code: *91.
Call Forward No Answer Activate	<ul style="list-style-type: none"> Default Code: *92. Enter the code and follow the voice prompt. Or enter the code followed by the extension to forward the call.
Call Forward No Answer Deactivate	<ul style="list-style-type: none"> Default Code: *93.
Call Forward Unconditional Activate	<ul style="list-style-type: none"> Default Code: *72. Enter the code and follow the voice prompt. Or enter the code followed by the extension to forward the call.
Call Forward Unconditional Deactivate	<ul style="list-style-type: none"> Default Code: *73.

Feature Misc	
Feature Code Digits Timeout	<ul style="list-style-type: none"> • Default Setting: 1000. • Configure the maximum interval (in milliseconds) between the digits input to activate the feature code.
Call Park	<ul style="list-style-type: none"> • Default Extension: 700. • During an active call, initiate blind transfer and then enter this code to park the call.
Parked Lots	<ul style="list-style-type: none"> • Default Extension: 701-720. • These are the extensions where the calls will be parked, i.e., parking lots that the parked calls can be retrieved.
Parking Timeout (s)	<ul style="list-style-type: none"> • Default setting: 300. • This is the timeout allowed for a call to be parked. After the timeout, if the call is not picked up, the extension who parks the call will be called back.
Feature Codes	
Voicemail Access Code	<ul style="list-style-type: none"> • Default Code: *98. • Enter *98 and follow the voice prompt. Or dial *98 followed by the extension and # to access the entered extension's voicemail box.
My Voicemail	<ul style="list-style-type: none"> • Default Code: *97. • Press *97 to access the voicemail box.
Agent Pause	<ul style="list-style-type: none"> • Default Code: *83. • Pause the agent in all call queues.
Agent Unpause	<ul style="list-style-type: none"> • Default Code: *84. • Unpause the agent in all call queues.
Paging Prefix	<ul style="list-style-type: none"> • Default Code: *81. • To page an extension, enter the code followed by the extension number.
Intercom Prefix	<ul style="list-style-type: none"> • Default Code: *80. • To intercom an extension, enter the code followed by the extension number.
Blacklist Add	<ul style="list-style-type: none"> • Default Code: *40. • To add a number to blacklist for inbound route, dial *40 and follow the voice prompt to enter the number.
Blacklist Remove	<ul style="list-style-type: none"> • Default Code: *41. • To remove a number from current blacklist for inbound route, dial *41 and follow the voice prompt to remove the number.

Call Pickup on Ringing	<ul style="list-style-type: none"> • Default Code: **. • To pick up a call for any extension xxxx, enter the code followed by the extension number xxxx.
Pickup Extension	<ul style="list-style-type: none"> • Default Code: *8. • This code is for the pickup group which can be assigned for each extension on the extension configuration page. • If there is an incoming call to an extension, the other extensions within the same pickup group can dial *8 directly to pick up the call.
Direct Dial Voicemail Prefix	<ul style="list-style-type: none"> • Default Code: * • This code is for the user to directly dial or transfer to an extension's voicemail. • For example, directly dial *5000 will have to call go into the extension 5000's voicemail. If the user would like to transfer the call to the extension 5000's voicemail, enter *5000 as the transfer target number.

CALL RECORDING

The UCM6510 allows users to record audio during the call. If "Auto Record" is turned on for extension or trunk, the call will be automatically recorded when there is established call with the extension or trunk. Otherwise, please follow the instructions below to manually record the call.

1. Make sure the feature code for "Audio Mix Record" is configured and enabled.
2. After establishing the call, enter the "Audio Mix Record" feature code (by default *3) followed by # or SEND to start recording.
3. To stop the recording, enter the "Audio Mix Record" feature code (by default *3) followed by # or SEND again. Or the recording will be stopped once the call hangs up.
4. The recording file can be retrieved under web GUI->**Status**->**CDR**. Click on  to play the recording or click on  to download the recording file.

[View Report](#)

Click on the title of the column to sort by column. Click on the row to display full record. View: 10

No.	Start Time	Call From	Call To	Call Time	Talk Time	Status	Options
1	2013-07-03 17:55:04	6000	5001	0:00:18	0:00:16		
2	2013-07-03 17:54:32	6000	5001	0:00:19	0:00:18		
3	2013-07-03 17:53:11	6000	6300	0:00:11	0:00:11		

Figure 82: Download Recording File from CDR Page

The above recorded call's recording files are also listed under the UCM6510 web GUI->CDR->**Recording Files**.

CALL PARK

The UCM6510 provides call park and call pickup features via feature code.

PARK A CALL

There are two feature codes that can be used to park the call.

- Feature Maps->Call Park (Default code #72)
During an active call, press #72 and the call will be parked. Parking lot number (default range 701 to 720) will be announced after parking the call.
- Feature Misc->Call Park (Default code 700)
During an active call, initiate blind transfer (default code #1) and then dial 700 to park the call. Parking lot number (default range 701 to 720) will be announced after parking the call.

RETRIEVE THE PARKED CALL

To retrieve the parked call, simply dial the parking lot number and the call will be established. If a parked call is not retrieved after the timeout, the original extension who parks the call will be called back.

This page intentionally left blank

INTERNAL OPTIONS

This section describes internal options that haven't been mentioned in previous sections yet. The settings in this section can be applied globally to the UCM6510, including general configurations, jitter buffer, RTP settings, hardware config and STUN monitor. The options can be accessed via web GUI->**PBX->Internal Options**.

INTERNAL OPTIONS/GENERAL

Table 51: Internal Options/General

General Preferences	
Global OutBound CID	Configure the global CallerID used for all outbound calls when no other CallerID is defined with higher priority. If no CallerID is defined for extension or trunk, the global outbound CID will be used as CallerID.
Global OutBound CID Name	Configure the global CallerID Name used for all outbound calls. If configured, all outbound calls will have the CallerID Name set to this name. If not, the extension's CallerID Name will be used.
Operator Extension	Specify the operator extension, which will be dialed when users presses 0 to exit voicemail application. The operator extension can also be used in IVR option.
Ring Timeout	Configure the number of seconds to ring an extension before the call goes to the user's voicemail box. The default setting is 60. Note: This is the global value used for each extension if "Ring Timeout" field is left empty on the extension configuration page.
Record Prompt	If enabled, users will hear voice prompt before recording is started or stopped. For example, before recording, the UCM6510 will play voice prompt "The call will be recorded". The default setting is "No".
Extension Preferences	
Enforce Strong Passwords	If enabled, strong password will be enforced for the password created on the UCM6510. The default setting is enabled. Strong Password Rules: 1. Password for voicemail, voicemail group, outbound route, DISA, call queue and conference requires non-repetitive and non-sequential digits, with a minimum length of 4 digits. Repetitive digits pattern

	<p>(such as 0000, 1111, 1234, 2345, and etc), or common digits pattern (such as 111222, 321321 and etc) are not allowed to be configured as password.</p> <p>2. Password for extension registration, web GUI admin login, LDAP and LDAP sync requires alphanumeric characters containing at least two categories of the following, with a minimum length of 4 characters.</p> <ul style="list-style-type: none"> • Numeric digits • Lowercase alphabet characters • Uppercase alphabet characters • Special characters
Enable Random Password	<p>If enabled, random password will be generated when the extension is created. The default setting is "Yes". It is recommended to enable it for security purpose.</p>
Disable Extension Range	<p>If set to "Yes", users could disable the extension range pre-configured/configured on the UCM6510. The default setting is "No".</p> <p>The default extension range assignment is:</p> <p>Note: It is recommended to keep the system assignment to avoid inappropriate usage and unnecessary issues.</p>
Extension Ranges	<p>The default extension range assignment is:</p> <ul style="list-style-type: none"> • User Extensions: 1000-6299 User Extensions is referring to the extensions created under web UI->PBX->Basic/Call Routes->Extensions page. • Pick Extensions: 4000-4999 This refers to the extensions that can be manually picked from end device when being provisioned by the UCM6510. There are two related options in zero config page->Auto Provision Settings, "Pick Extension Segment" and "Enable Pick Extension". If "Enable Pick Extension" under zero config settings is selected, the extension list defined in "Pick Extension Segment" will be sent out to the device after receiving the device's request. This "Pick Extension Segment" should be a subset of the "Pick Extensions" range here. This feature is for the GXP series phones that support selecting extension to be provisioned via phone's LCD. • Auto Provision Extensions: 5000-6299

	<p>This sets the range for "Zero Config Extension Segment" which is the extensions can be assigned on the UCM6510 to provision the end device.</p> <ul style="list-style-type: none"> • Conference Extensions: 6300-6399 • Ring Group Extensions: 6400-6499 • Queue Extensions: 6500-6599 • Voicemail Group Extensions: 6600-6699 • IVR Extensions: 7000-7100 • Fax Extensions: 7200-8200
--	---

INTERNAL OPTIONS/JITTER BUFFER

Table 52: Internal Options/Jitter Buffer

SIP Jitter Buffer	
Enable Jitter Buffer	Select to enable jitter buffer on the sending side of the SIP channel. The default setting is "No".
Jitter Buffer Size	Configure the time (in ms) to buffer. This is the jitter buffer size used in "Fixed" jitter buffer, or used as the initial time for "adaptive" jitter buffer. The default setting is 100.
Max Jitter Buffer	Configure the maximum time (in ms) to buffer for "Adaptive" jitter buffer implementation, or used as the jitter buffer size for "Fixed" jitter buffer implementation. The default setting is 200.
Implementation	<p>Configure the jitter buffer implementation on the sending side of a SIP channel. The default setting is "Fixed".</p> <ul style="list-style-type: none"> • Fixed The size is always equal to the value of "Max Jitter Buffer". • Adaptive The size is adjusted automatically and the maximum value equals to the value of "Max Jitter Buffer".

INTERNAL OPTIONS/RTP SETTINGS

Table 53: Internal Options/RTP Settings

RTP Start	Configure the RTP port starting number. The default setting is 10000.
RTP End	Configure the RTP port ending address. The default setting is 20000.
Strict RTP	Configure to enable or disable strict RTP protection. If enabled, RTP packets that do not come from the source of the RTP stream will be dropped. The default setting is "Disable".

RTP Checksums	Configure to enable or disable RTP Checksums on RTP traffic. The default setting is "Disable".
---------------	--

INTERNAL OPTIONS/STUN MONITOR

Table 54: Internal Options/STUN Monitor

STUN Server	<p>Configures the IP address or URL of the STUN server to query. If not specified, STUN is disabled. The default setting is stun.ipvideotalk.com.</p> <p>Valid format: [(hostname IP-address) [:' port] The default port number is 3478 if not specified.</p>
STUN Refresh	Configure the number of seconds between STUN Refreshes. The default setting is 30 seconds.

IAX SETTINGS

The UCM6510 IAX global settings can be accessed via web GUI->**PBX->IAX Settings**.

IAX SETTINGS/GENERAL

Table 55: IAX Settings/General

Bind Port	Configure the port number that the IAX2 will be allowed to listen to. The default setting is 4569.
Bind Address	Configure the address that the IAX2 will be forced to bind to. The default setting is 0.0.0.0, which means all addresses.
IAX1 Compatibility	Select to configure IAX1 compatibility. The default setting is "No".
No Checksums	If selected, UDP checksums will be disabled and no checksums will be calculated/checked on systems supporting this features. The default setting is "No".
Delay Reject	If enabled, the IAX2 will delay the rejection of calls to avoid DOS. The default setting is "No".
ADSI	Select to enable ADSI phone compatibility. The default setting is "No".
Music On Hold Interpret	Specify which Music On Hold class this channel would like to listen to when being put on hold. This music class is only effective if this channel has no music class configured and the bridged channel putting the call on hold has no "Music On Hold Suggest" setting.
Music On Hold Suggest	Specify which Music On Hold class to suggest to the bridged channel when putting the call on hold.
Bandwidth	Configure the bandwidth for IAX settings. The default setting is "Low".

IAX SETTINGS/REGISTRATION

Table 56: IAX Settings/Registration

IAX Registration Options	
Min Reg Expire	Configure the minimum period (in seconds) of registration. The default setting is 60.
Max Reg Expire	Configure the maximum period (in seconds) of registration. The default setting is 3600.
IAX Thread Count	Configure the number of IAX helper threads. The default setting is 10.
IAX Max Thread Count	Configure the maximum number of IAX threads allowed. The default

	setting is 100.
Auto Kill	If set to "yes", the connection will be terminated if ACK for the NEW message is not received within 2000ms. Users could also specify number (in milliseconds) in addition to "yes" and "no". The default setting is "yes".
Authentication Debugging	If enabled, authentication traffic in debugging will not show. The default setting is "No".
Codec Priority	Configure codec negotiation priority. The default setting is "Reqonly". <ul style="list-style-type: none"> • Caller Consider the callers preferred order ahead of the host's. • Host Consider the host's preferred order ahead of the caller's. • Disabled Disable the consideration of codec preference all together. • Reqonly This is almost the same as "Disabled", except when the requested format is not available. The call will only be accepted if the requested format is available.
Type of Service	Configure ToS bit for preferred IP routing.
IAX Trunk Options	
Trunk Frequency	Configure the frequency of trunk frames (in milliseconds). The default setting is 20.
Trunk Time Stamps	If enabled, time stamps will be attached to trunk frames. The default setting is "No".

IAX SETTINGS/STATIC DEFENSE

Table 57: IAX Settings/Static Defense

Call Token Optional	Enter a single IP address or a range of IP addresses for which call token validation is not required. For example: 11.11.11.11 11.11.11.11/22.22.22.22.
Max Call Numbers	Configure the maximum number of calls allowed for a single IP address.
Max Unvalidated Call Numbers	Configure the maximum number of unvalidated calls for all IP addresses.
Call Number Limits	Configure to limit the number of calls for a give IP address of IP range.
IP or IP Range	Enter the IP address or a range of IP addresses to be considered for call number limits.

For example:

11.11.11.11

11.11.11.11/22.22.22.22.

This page intentionally left blank

SIP SETTINGS

The UCM6510 SIP global settings can be accessed via web GUI->**PBX->SIP Settings**.

SIP SETTINGS/GENERAL

Table 58: SIP Settings/General

Realm For Digest Authentication	Configure the host name or domain name for the UCM6510. Realms MUST be globally unique according to RFC3261. The default setting is grandstream.
Bind UDP Port	Configure the UDP port used for SIP. The default setting is 5060.
Bind IP Address	Configure the IP address to bind to. The default setting is 0.0.0.0, which means binding to all addresses.
Allow Guest Calls	<p>If enabled, the UCM6510 allows unauthorized INVITE coming into the PBX and the call can be made. The default setting is "No".</p> <p>Warning: Please be aware of the potential security risk when enabling "Allow Guest Calls" as this will allow any user with the UCM6510 address to dial into the UCM6510.</p>
Overlap Dialing	Select to enable overlap dialing support. Overlap dial provides for a longer time-out period between digits, also called the inter-digit timer. If set to "Yes", the PBX expects to receive the digits one right after the other coming in to this line with very little delay between digits. If set to "No", the PBX waits up to about 2 seconds between digits. The default setting is "No".
Allow Transfer	If set to "No", all transfers initiated by the endpoint in the UCM6510 will be disabled (unless enabled in peers or users). The default setting is "Yes".
Enable DNS SRV Lookups on Outbound Calls	Select to enables DNS SRV lookups on outbound calls from the UCM6510. The default setting is "Yes".
MWI From	When sending MWI NOTIFY requests, this value will be used in the "From:" header as the "name" field. If no "From User" is configured, the "user" field of the URI in the "From:" header will be filled with this value.
SIP Domain Support	
Domain	Configure the domain for the UCM6510. Incoming INVITE and REFER messages can be matched against a list of "allowed" domains, each of which can direct the call to a specific context if desired. By default, all

	domains are accepted and sent to the default context or the context associated with the user/peer placing the call. Register to non-local domains will be automatically denied if a domain list is configured. Up to 10 domains can be added.
From Domain	Configure the domain in the "From:" header of the SIP message. It may be required by some providers for authentication.
Auto Domain	If enabled, the UCM6510 will add local host name and local IP to domain list. The default setting is "No".
Allow External Domains	If enabled, requests for external domains that are not served by the UCM6510 will be allowed. The default setting is "Yes".

SIP SETTINGS/MISC

Table 59: SIP Settings/Misc

Outbound SIP Registrations	
Register Timeout	Configure the register retry timeout (in seconds). The default setting is 20.
Register Attempts	Configure the number of registration attempts before the UCM6510 gives up. The default setting is 0, which means the UCM6510 will keep trying until the server side accepts the registration request.
Video	
Max Bit Rate (kb/s)	Configure the maximum bit rate (in kb/s) for video calls. The default setting is 384.
Support SIP Video	Select to enable video support in SIP calls. The default setting is "Yes".
Generate Manager Events	If enabled, the UCM6510 will generate manager events when SIP UA performs events (e.g. Hold). The default setting is "No".
Reject Non-Matching INVITE	If enabled, when rejecting an incoming INVITE or REGISTER request, the UCM6510 will always reject with "401 Unauthorized" instead of notifying the requester whether there is a matching user or peer for the request. This reduces the ability of an attacker to scan for valid SIP usernames. The default setting is "No".

SIP SETTINGS/SESSION TIMER

Table 60: SIP Settings/Session Timer

Session Timers	<p>Select the session timer mode. The default setting is "Accept".</p> <p>The options are:</p> <ul style="list-style-type: none"> • Originate <p>Always request and run session timer.</p>
----------------	---

	<ul style="list-style-type: none"> • Accept Run session timer only when requested by other UA. • Refuse Do not run session timer.
Session Expire	Configure the maximum session refresh interval (in seconds). The default setting is 1800.
Min SE	Configure the minimum session refresh interval (in seconds). The default setting is 90.
Session Refresher	Select the session refresher to be UAC or UAS. The default setting is UAC.

SIP SETTINGS/TCP and TLS



Note:

The configuration in this section require system reboot to take effect.

Table 61: SIP Settings/TCP and TLS

TCP Enable	Configure to allow incoming TCP connections with the UCM6510. The default setting is "No".
TCP Bind Address	Configure the IP address for TCP server to bind to. 0.0.0.0 means binding to all interfaces. The port number is optional. If not specified, 5060 will be used.
TLS Enable	Configure to allow incoming TLS connections with the UCM6510. The default setting is "No".
TLS Bind Address	<p>Configure the IP address for TLS server to bind to. 0.0.0.0 means binding to all interfaces. The port number is optional. If not specified, 5061 will be used.</p> <p>Note: The IP address must match the common name (hostname) in the certificate. Please do not bind a TLS socket to multiple IP addresses. For details on how to construct a certificate for SIP, please refer to the following document: http://tools.ietf.org/html/draft-ietf-sip-domain-certs</p>

TLS Client Protocol	Select the TLS protocol for outbound client connections. The default setting is TLSv1.
TLS Do Not Verify	If enabled, the TLS server's certificate won't be verified when acting as a client. The default setting is "Yes".
TLS Self-Signed CA	This is the CA certificate if the TLS server being connected to requires self-signed certificate, including server's public key. This file will be renamed as "TLS.ca" automatically. Note: The size of the uploaded ca file must be under 2MB.
TLS Cert	This is the Certificate file (*.pem format only) used for TLS connections. It contains private key for client and signed certificate for the server. This file will be renamed as "TLS.pem" automatically. Note: The size of the uploaded certificate file must be under 2MB.
TLS CA Cert	This file must be named with the CA subject name hash value. It contains CA's (Certificate Authority) public key, which is used to verify the accessed servers. Note: The size of the uploaded CA certificate file must be under 2MB.
TLS CA List	Display a list of files under the CA Cert directory.

SIP SETTINGS/NAT

Table 62: SIP Settings/NAT

External IP Address	Configure a static address and port (optional) that will be used in outbound SIP messages if the UCM6510 is behind NAT. If it's a hostname, it will only be looked up once.
External Host	Specify an external host name, which is similar to External Address except the host name will be looked up periodically based on the "External Refresh" interval.
External Refresh	Configure the refresh interval for the external host (if used) The default setting is 10.
External TCP Port	Configure the externally mapped TCP port when the UCM6510 is behind a static NAT or PAT.

External TLS Port	Configures the externally mapped TLS port when UCM6510 is behind a static NAT or PAT.
Local Network Address	Specify a list of network addresses that are considered inside of the NAT network. Multiple entries are allowed. If not configured, the external IP address will not be set correctly. A sample configuration could be as follows: 192.168.0.0/16

SIP SETTINGS/TOS

Table 63: SIP Settings/ToS

ToS For SIP	Configure the Type of Service for SIP packets. The default setting is None.
ToS For RTP Audio	Configure the Type of Service for RTP audio packets. The default setting is None.
ToS For RTP Video	Configure the Type of Service for RTP video packets. The default setting is None.
Default Incoming/Outgoing Registration Time	Configure the default duration (in seconds) of incoming/outgoing registration. The default setting is 120.
Max Registration/Subscription Time	Configure the maximum duration (in seconds) of incoming registration and subscription allowed by the UCM6510. The default setting is 3600.
Min Registration/Subscription Time	Configure the minimum duration (in seconds) of incoming registration and subscription allowed by the UCM6510. The default setting is 60.
Music On Hold Interpret	Configure the Music On Hold class for the channel when being put on hold. This is used when the Music On Hold class is not set on the channel and the peer channel placing the call on hold doesn't have "Music On Hold Suggest".
Music On Hold Suggest	Configure the Music On Hold class to suggest to the peer channel when placing the peer on hold.
Enable Relaxed DTMF	Select to enable relaxed DTMF handling. The default setting is "No".
DTMF Mode	Select DTMF mode to send DTMF. The default setting is RFC2833. If "Info" is selected, SIP INFO message will be used. If "Inband" is selected, 64-kbit codec PCMU and PCMA are required. When "Auto" is selected, "RFC2833" will be used if offered, otherwise "Inband" will be used. The default setting is "RFC2833".
RTP Timeout	During an active call, if there is no RTP activity within the timeout (in seconds), the call will be terminated. The default setting is no timeout.

	<p>Note: This setting doesn't apply to calls on hold.</p>
RTP Hold Timeout	When the call is on hold, if there is no RTP activity within the timeout (in seconds), the call will be terminated. This value of RTP Hold Timeout should be larger than RTP Timeout. The default setting is no timeout.
Trust Remote Party ID	Configure whether the Remote-Party-ID should be trusted. The default setting is "No".
Send Remote Party ID	Configure whether the Remote-Party-ID should be sent or not. The default setting is "No".
Generate In-Band Ringing	<p>Configure whether the UCM6510 should generate inband ringing or not. The default setting is "Never".</p> <ul style="list-style-type: none"> • Yes: The UCM6510 will send 180 Ringing followed by 183 Session Progress and in-band audio. • No: The UCM6510 will send 180 Ringing if 183 Session Progress has not been sent yet. If audio path is established already with 183 then send in-band ringing. • Never: Whenever ringing occurs, the UCM6510 will send 180 Ringing as long as 200OK has not been set yet. Inband ringing will not be generated even the end point device is not working properly.
Server User Agent	Configure the user agent string for the UCM6510.
Send Compact SIP Headers	If enabled, compact SIP headers will be sent. The default setting is "No".
Add "user=phone" to URI	If enabled, "user=phone" will be added to URI that contains a valid phone number. The default setting is "No".

STATUS AND REPORTING

PBX STATUS

The UCM6510 monitors the status for Trunks, Extensions, Queues, Conference Rooms, Interfaces, Digital Channels and Parking lot. It presents administrators the real time status in different sections under web GUI->**Status->PBX Status**.

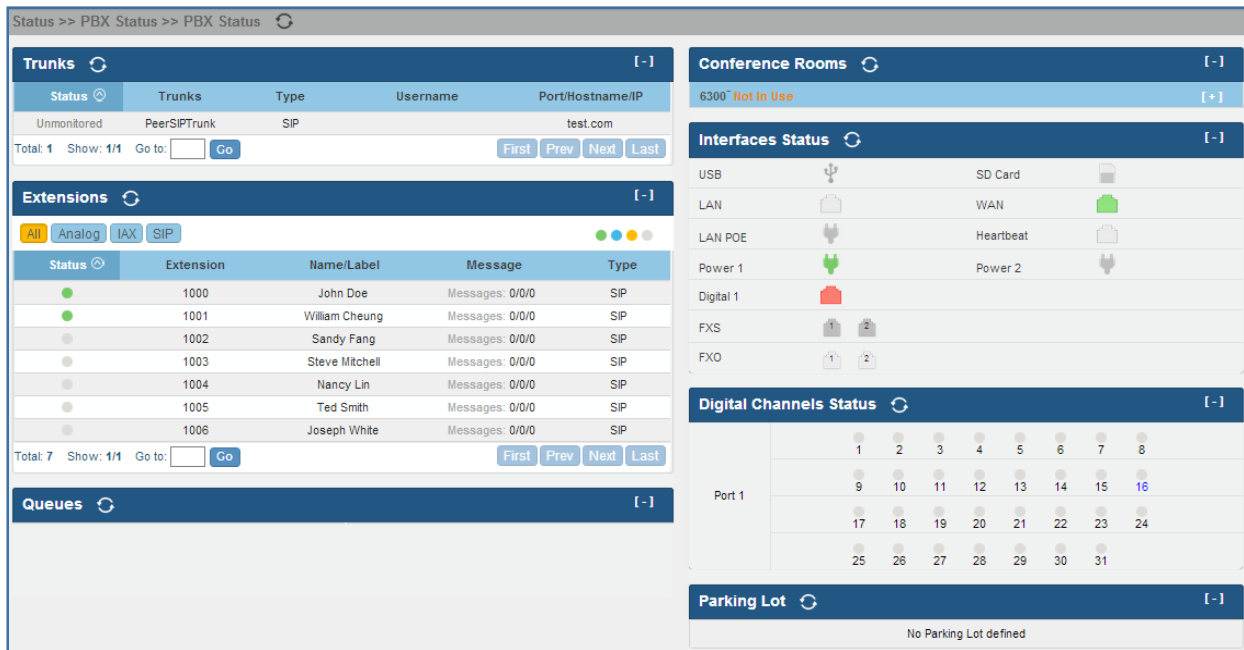

The screenshot displays the PBX Status web GUI with the following sections:

- Trunks:** A table with columns: Status, Trunks, Type, Username, Port/Hostname/IP. It shows one entry: Unmonitored, PeerSIPTrunk, SIP, test.com.
- Extensions:** A table with columns: Status, Extension, Name/Label, Message, Type. It lists extensions 1000 through 1006 with names like John Doe, William Cheung, etc.
- Queues:** A section with a refresh icon and a minus sign, currently empty.
- Conference Rooms:** Shows 6300 Not In Use.
- Interfaces Status:** A grid showing the status of various interfaces like USB, LAN, LAN POE, Power 1, Digital 1, FXS, and FXO.
- Digital Channels Status:** A grid showing the status of digital channels 1 through 31.
- Parking Lot:** Shows "No Parking Lot defined".

Figure 83: Status->PBX Status

TRUNKS

Users could see all the configured trunk status in this section.

Status	Trunks	Type	Username	Port/Hostname/IP
Unmonitored	Grandstream	SIP		192.168.40.140
Unavailable	Trunk1	Analog		Ports 1

Figure 84: Trunk Status

Table 64: Trunk Status

Status	<p>Display trunk status.</p> <ul style="list-style-type: none"> Analog trunk/Digital trunk status: <ul style="list-style-type: none"> Available Busy Unavailable Unknown Error Error Configured: Incorrect signaling configuration between the two devices. For example, both of the devices are configured as CPE or NET. SIP Peer trunk status: <ul style="list-style-type: none"> Unreachable: The hostname cannot be reached. Unmonitored: QUALIFY feature is not turned on to be monitored. Reachable: The hostname can be reached. SIP Register trunk status: <ul style="list-style-type: none"> Registered Unrecognized Trunk
Trunks	Display trunk name
Type	<p>Display trunk Type:</p> <ul style="list-style-type: none"> Analog E1/T1 SIP IAX
Username	Display username for this trunk.
Port/Hostname/IP	Display Port for analog trunk, or Hostname/IP for VoIP (SIP/IAX) trunk.

Other operations are also available in trunk status section:

- Click on "Trunks", the web page will redirect to trunk configuration page which can also be accessed via web GUI->**PBX->Basic/Call Routes->Analog Trunks**.
- Click on  to refresh the trunk status.
- Click on [+] to expand the status detail table.
- Click on [-] to hide the status detail table.

EXTENSIONS

Users could see all the configured extension status in this section.

Status	Extension	Name/Label	Message	Type
●	1000	GXP2140	Messages: 0/0/0	SIP
●	1001	HT701	Messages: 0/0/0	SIP
●	1005		Messages: 0/0/0	FXS1
●	1002	HT704	Messages: 0/0/0	SIP
●	1003		Messages: 0/0/0	SIP
●	1004		Messages: 0/0/0	SIP

Total: 6 Show: 1/1 Go to: Go First Prev Next Last

Figure 85: Extension Status

Table 65: Extension Status

Status	<p>Display extension number (including feature code). The color indicator has the following definitions.</p> <ul style="list-style-type: none"> ● Green: Free ● Blue: Ringing ● Yellow: In Use ● Grey: Unavailable
Extension	Display the extension number.
Name/Label	Display name (callerID name) or label for the extension.
Message	<p>Display message status for the extension.</p> <p>Example: 2/4/1</p> <p>Description: There are 2 urgent messages, 4 messages in total and 1 message that has been already read.</p>
Type	<p>Displays extension type.</p> <ul style="list-style-type: none"> SIP User IAX User Analog User (FXS) Features

Other operations are also available in extension status section:

- Click on "Extensions", the web page will redirect to extension configuration page which can also be accessed via web GUI->**PBX->Basic/Call Routes->Extensions**.
- Click on  to refresh the extension status.

- Click on one of the tabs **All** **Analog** **Features** **IAX** **SIP** to display the corresponding extensions accordingly.
- Click on [+] to expand the status detail table.
- Click on [-] to hide the status detail table.

QUEUES

Users could see all the configured call queue status in this section. The following figure shows the call queue 6500 being in used.

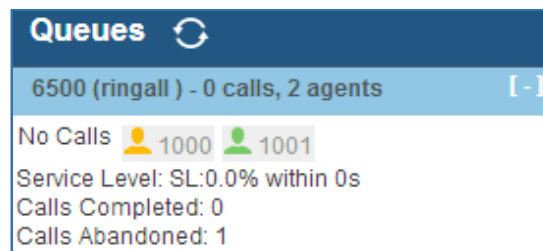





Figure 86: Queue Status

The current call status (caller ID, duration), agent status, service level, calls summary (completed/abandoned) are shown for the call queue. The agent status is defined as below.

Table 66: Agent Status

	The agent is available/idle.
	The agent is ringing.
	The agent is talking/busy.
	The agent has been logged out.

On the UCM6510, **Service Level** is defined as the percentage of high-quality calls over all calls in the call queue, where high-quality call means calls answered within 10 seconds.

Other operations are also available in queue status section:

- Click on "Queues", the web page will redirect to call queue configuration page which can also be accessed via web GUI->**PBX**->**Call Features**->**Call Queue**.
- Click on  to refresh the call queue status.
- Click on [+] to expand the call queue detail.
- Click on [-] to hide the call queue detail.

CONFERENCE ROOMS

Users could see all the conference room status in this section. It shows all the configured conference rooms, current users, call duration for each user and conference call.



Conference Rooms  [-]			
6300 3 Users [-]			
0:37		6000	0:37
		6005	0:36
		6007	0:16
6301 Not In Use [+]			

Figure 87: Conference Room Status





Other operations are also available in conference room status section:















- Click on "Conference Rooms", the web page will redirect to conference room configuration page which can also be accessed via web GUI->**PBX->Call Features->Conference**.
- Click on  to refresh the conference room status.
- Click on [+] to expand the conference room details.
- Click on [-] to hide the conference room details.





INTERFACES STATUS

This section displays interface connection status on the UCM6510 for USB, SD Card, LAN, WAN, LAN PoE, Heartbeat, Power 1, Power 2, Digital, FXS and FXO ports.

Table 67: Interface Status Indicators

FXO	
	Disconnected
	Connected but not configured
	Connected and idle
	Connected and in use
FXS	

	Connected but not configured
	Connected and idle
	Connected and in use
SD Card	
	SD Card plugged in
	SD Card unplugged
USB	
	USB plugged in
	USB unplugged
LAN PoE	
	PoE is used
	PoE is not used
Power 1/2	
	Power supply is working
	Power supply is abnormal
	No power supply
LAN/WAN/Heart Beat	
	Connected
	Not connected
Digital Port T1/E1/J1	

	Connected and working
	RED alarm: there is physical wiring problem, loss of connectivity, or a framing/line-coding mismatch with the remote switch.
	<p>YELLOW alarm: connected but the link is working only one-way. This means that the remote switch is not able to maintain sync with you, or is not receiving your transmission.</p> <p>The following example scenarios could trigger YELLOW alarm:</p> <ol style="list-style-type: none"> 1. The T1 port is connected with J1 connection. 2. Incorrect cable is used. 3. When using E1, one end is using CRC4 while the other end is not.
	BLUE alarm: the port goes into BLUE alarm when it receives all unframed 1s on all timeslots from the remote switch. This is a special signal to indicate that the remote switch is having problem with its upstream connection.
	Cannot start up

Other operations are also available in interface status section:

- Click on  to refresh the interface status.
- Click on [+] to expand the interface details.
- Click on [-] to hide the interface details.

DIGITAL CHANNELS STATUS

This section displays the status of the digital trunks on the UCM6510.

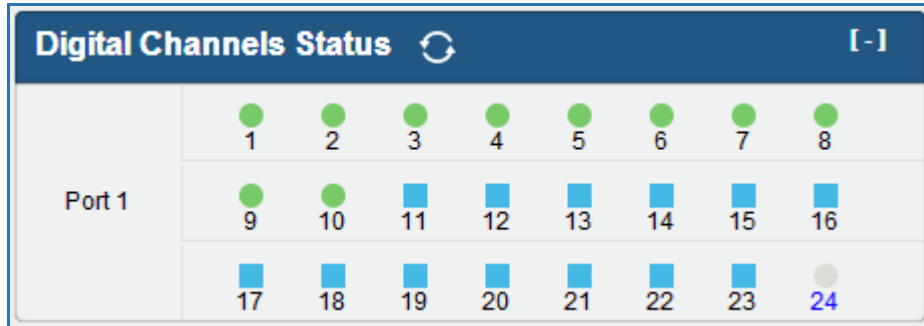









Figure 88: Digital Channels Status

Table 68: Digital Channel Status Indicators

Voice Channel	
	Not available
	Connected and in talking status; or incorrect configuration
	Connected and in idle status
	Connected and in ringing status
Data Channel	
	Always shows blue square
D Channel	
	Always shows grey with channel number in blue.

Other operations are also available in interface status section:

- Click on  to refresh the Digital Channels status.
- Click on [+] to expand the Digital Channels Status details.
- Click on [-] to hide the Digital Channels Status details.

PARKING LOT

The UCM6510 supports call park using feature code. When there is call being parked, this section will display the parking lot status.

Parking Lot 				[-]
Caller ID	Channel	Extension	Timeout	
6010	SIP/6010-00000050	701	96	
6005	SIP/6005-00000052	702	113	

Figure 89: Parking Lot Status

Table 69: Parking Lot Status

Caller ID	Display the caller ID who parks the call.
Channel	Display channel for the call park.
Extension	Display the parking lot number where the call is parked/retrieved.
Timeout	Display timeout (in seconds) for the parked call. The status page will dynamically update this timer from 120 seconds (default) to 0. When the timer reaches 0, the caller who parks the call will be called back.

Other operations are also available in parking lot status section:

- Click on "Parking Lot", the web page will redirect to feature codes page which can also be accessed via web GUI->**PBX->Internal Options->Feature Codes**.
- Click on  to refresh the parking lot status.
- Click on [+] to expand the parking lot details.
- Click on [-] to hide the parking details.

SYSTEM STATUS

The UCM6510 system status can be accessed via web GUI->**Status->System Status**, which displays the following system information.

- **General**
- **Network**
- **Storage Usage**
- **Resource Usage**

GENERAL

Under web GUI->**Status->System Status->General**, users could check the hardware and software information for the UCM6510. Please see details in the following table.

Table 70: System Status->General

Status ->System Status -> General	
Model	Product model.
Part Number	Product part number.
System Time	Current system time. The current system time is also available on the upper right of each web page.
Up Time	System up time since the last reboot.
Idle Time	System idle time since the last reboot.
Boot	Boot version.
Core	Core version.
Base	Base version.
Program	Program version. This is the main software release version.
Recovery	Recovery version.

NETWORK

Under web GUI->**Status->System Status->Network**, users could check the network information for the UCM6510. Please see details in the following table.

Table 71: System Status->Network

Status -> System Status -> Network	
MAC Address	Global unique ID of device, in HEX format. The MAC address can be found on the label coming with original box and on the label located on the bottom of the device.
IP Address	IP address.
Gateway	Default gateway address.
Subnet Mask	Subnet mask address.
DNS Server	DNS Server address.

STORAGE USAGE

Users could access the storage usage information from web GUI->**Status->System Status->Storage Usage**. It shows the available and used space for the following partitions.

- Configuration partition
This partition contains PBX system configuration files and service configuration files.
- Data partition
Voicemail, recording files, IVR file, Music On Hold files and etc.
- USB disk
USB disk will display if connected.
- SD Card
SD Card will display if connected.

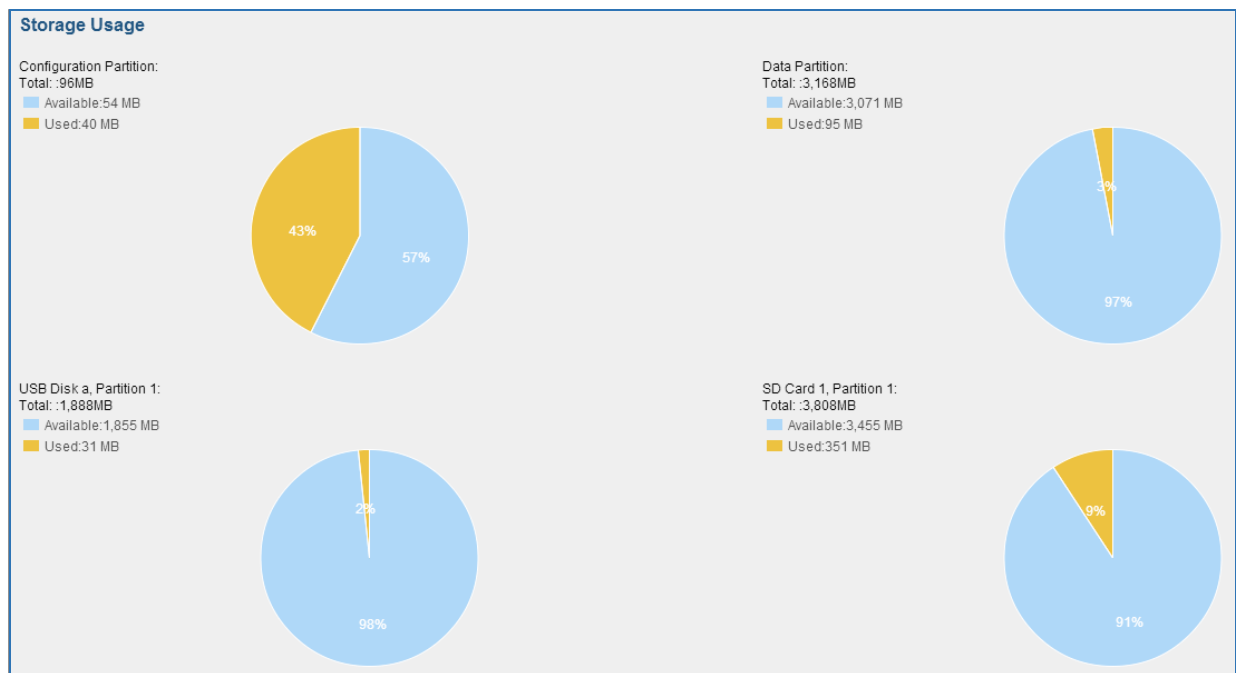

Figure 90: System Status->Storage Usage

RESOURCE USAGE

When configuring and managing the UCM6510, users could access resource usage information to estimate the current usage and allocate the resources accordingly. Under web GUI->**Status->System Status->Resource Usage**, the current CPU usage and Memory usage are shown in the pie chart.

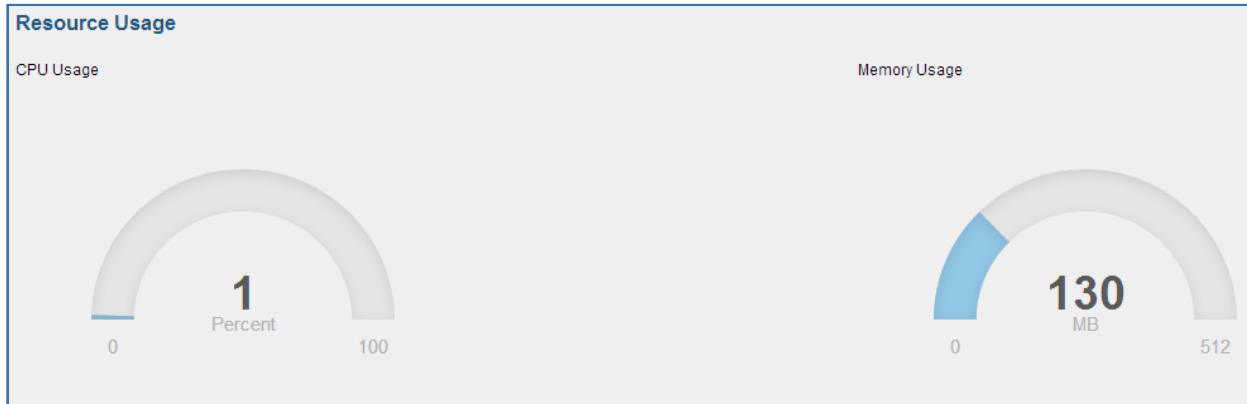



Figure 91: System Status->Resource Usage

SYSTEM EVENTS

The UCM6510 can monitor important system events, log the alerts and send Email notifications to the system administrator.

ALERT EVENTS LIST

The system alert events list can be found under web GUI->**Status->System Events->Alert Events List**.

Click on  to configure the parameters for each event.

1. Disk Usage

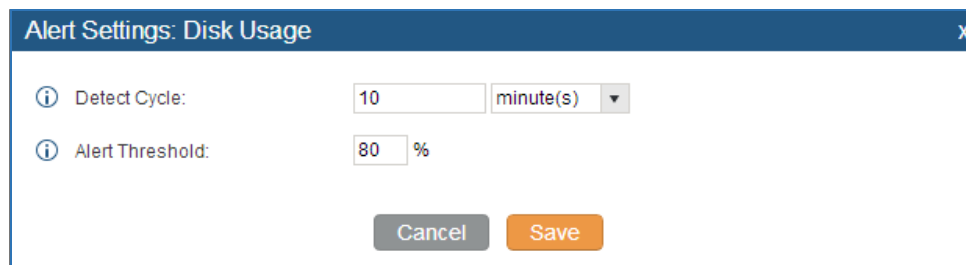

The figure shows a dialog box titled 'Alert Settings: Disk Usage'. It contains two configuration fields: 'Detect Cycle' set to 10 with a dropdown menu showing 'minute(s)', and 'Alert Threshold' set to 80 with a '%' symbol. At the bottom, there are 'Cancel' and 'Save' buttons.

Figure 92: System Events->Alert Events Lists: Disk Usage

- **Detect Cycle:** The UCM6510 will perform the internal disk usage detection based on this cycle. Users can enter the number and then select second(s)/minute(s)/hour(s)/day(s) to configure the cycle.

- **Alert Threshold:** If the detected value exceeds the threshold (in percentage), the UCM6510 system will send the alert.

2. Modify Admin Password

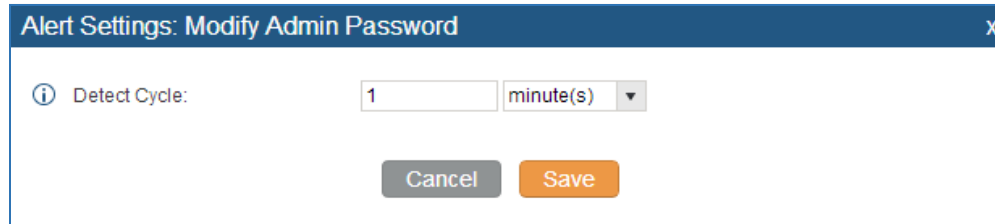

The dialog box titled "Alert Settings: Modify Admin Password" contains a "Detect Cycle" field with the value "1" and a dropdown menu set to "minute(s)". Below the field are "Cancel" and "Save" buttons.

Figure 93: System Events->Alert Events Lists: Modify Admin Password

- **Detect Cycle:** The UCM6510 will initiate the admin password check based on this cycle. Users can enter the number and then select second(s)/minute(s)/hour(s)/day(s) to configure the cycle.

3. Memory Usage

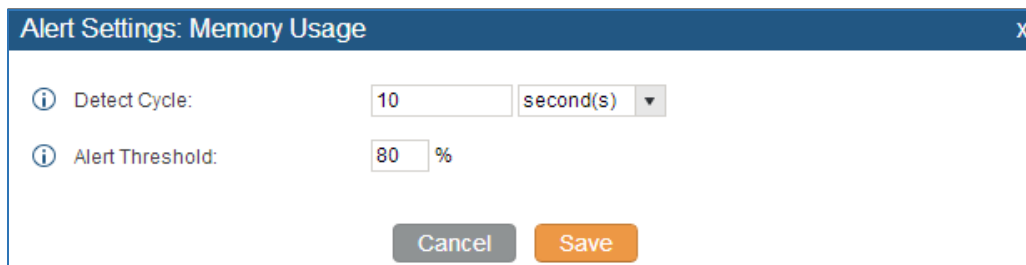

The dialog box titled "Alert Settings: Memory Usage" contains two fields: "Detect Cycle" with the value "10" and a dropdown menu set to "second(s)", and "Alert Threshold" with the value "80" and a percentage sign. Below the fields are "Cancel" and "Save" buttons.

Figure 94: System Events->Alert Events Lists: Memory Usage

- **Detect Cycle:** The UCM6510 will perform the memory usage detection based on this cycle. Users can enter the number and then select second(s)/minute(s)/hour(s)/day(s) to configure the cycle.
- **Alert Threshold:** If the detected value exceeds the threshold (in percentage), the UCM6510 system will send the alert.

4. System Reboot

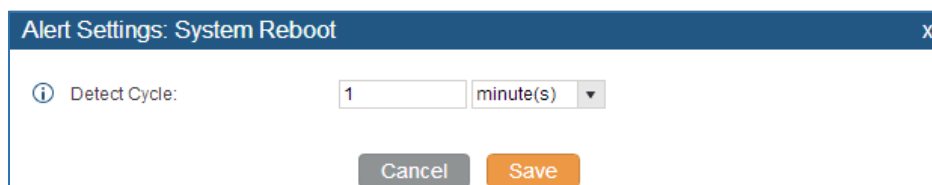

The dialog box titled "Alert Settings: System Reboot" contains a "Detect Cycle" field with the value "1" and a dropdown menu set to "minute(s)". Below the field are "Cancel" and "Save" buttons.

Figure 95: System Events->Alert Events Lists: System Reboot

- **Detect Cycle:** The UCM6510 will check the system reboot based on this cycle. Users can enter the number and then select second(s)/minute(s)/hour(s)/day(s) to configure the cycle.

5. System Update

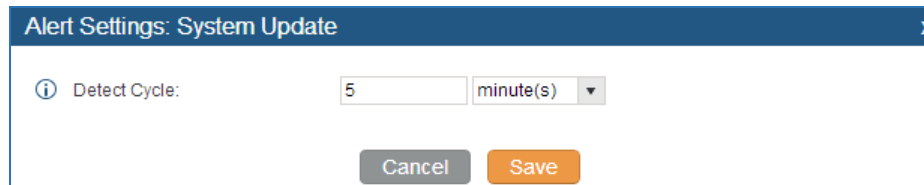

The screenshot shows a dialog box titled "Alert Settings: System Update". It contains a "Detect Cycle:" label, a text input field with the value "5", and a dropdown menu set to "minute(s)". Below the input field are two buttons: "Cancel" and "Save".

Figure 96: System Events->Alert Events Lists: System Update

- **Detect Cycle:** The UCM6510 will check the system update based on this cycle. Users can enter the number and then select second(s)/minute(s)/hour(s)/day(s) to configure the cycle.

6. System Crash

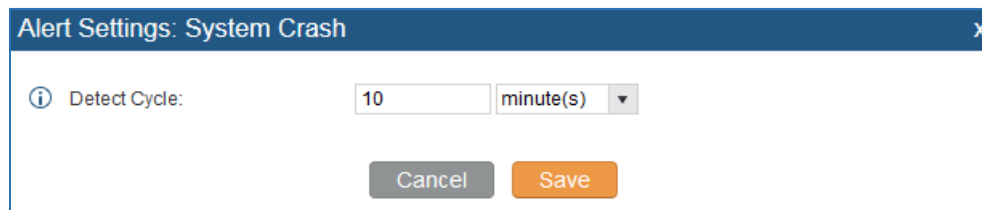

The screenshot shows a dialog box titled "Alert Settings: System Crash". It contains a "Detect Cycle:" label, a text input field with the value "10", and a dropdown menu set to "minute(s)". Below the input field are two buttons: "Cancel" and "Save".

Figure 97: System Events->Alert Events Lists: System Crash

- **Detect Cycle:** The UCM will detect the event at each cycle based on the specified time. Users can enter the number and then select second(s)/minute(s)/hour(s)/day(s) to configure the cycle.

Click on the switch OFF ON to turn on/off the alert and Email notification for the event. Users could also select the checkbox for each event and then click on button "Alert On", "Alert Off", "Email Notification On", "Email Notification Off" to control the alert and Email notification configuration.

ALERT LOG

Under web GUI->**Status->System Events->Alert Log**, system messages are listed when the alert is triggered for the configured system events. The following picture shows disk usage alert log. We can tell the detect cycle for the disk usage is 10 minutes and the disk usage is restored to normal after the administrator cleans up the disk storage below the threshold.

2013-10-09 21:32:00	Disk Usage	Generate Alert	Disk usage exceeds the threshold
2013-10-09 21:42:00	Disk Usage	Generate Alert	Disk usage exceeds the threshold
2013-10-09 21:52:00	Disk Usage	Generate Alert	Disk usage exceeds the threshold
2013-10-09 22:02:00	Disk Usage	Restore to normal	Disk usage has been restored to normal

Figure 98: System Events->Alert Log

ALERT CONTACT

Users could add administrator's Email address under web GUI->**Status->System Events->Alert Contact** to send the alert notification to. Up to 10 Email addresses can be added.

CDR

A Call Detail Record (CDR) is a data record produced by telephone exchange activities or other telecommunications equipment documenting the details of a phone call that passed through the PBX. The CDR is composed of the following data fields on the UCM6510.

- **Start Time.** Format: 2013-03-27 16:47:03.
- **Call From.** Format: "John Doe" <6012>.
- **Call To.** Format: 6005.
- **Call Time.** Format: 0:00:10.
- **Talk Time.** Format: 0:00:10
- **Status.** Format: NO ANSWER, BUSY, ANSWERED, or FAILED.
- **Options.** Voice record playing/downloading/deleting.

Users could filter the call report by specifying the date range and criteria, depending on how the users would like to include the logs to the report. Then click on "View Report" button to display the generated report.

Call Detail Report

Inbound calls:
Caller Number
Caller Name

Outbound calls:
From Date
To Date

Internal calls:

External calls:

[View Report](#)

Figure 99: CDR Filter

Table 72: CDR Filter Criteria

Inbound calls	Inbound calls are calls originated from a non-internal source (like a VoIP trunk) and sent to an internal extension.
Outbound calls	Outbound calls are calls sent to a non-internal source (like a VoIP trunk) from an internal extension.
Internal calls	Internal calls are calls from one internal extension to another extension, which are not sent over a trunk.
External calls	External calls are calls sent from one trunk to another trunk, which are not sent to any internal extension.
Caller Number	Enter the caller number to be filtered in the CDR report.
Caller Name	Enter the caller name to be filtered in the CDR report.
From Date	Specify "From" date and time to be filtered for the CDR report. Click on the field and the calendar will show for users to select the exact date and time.
To Date	Specify "To" date and time to be filtered for the CDR report. Click on the field and the calendar will show for users to select the exact date and time.

The call report will display as the following figure shows.

No.	Start Time	Call From	Call To	Call Time	Talk Time	Status	Options
1	2013-07-03 18:29:26	6000	701	0:00:03	0:00:03		
2	2013-07-03 18:29:00	6000	5001	0:00:23	0:00:22		
3	2013-07-03 18:28:51	6000	701	0:00:01	0:00:01		
4	2013-07-03 18:28:38	6000	5001	0:00:08	0:00:06		
5	2013-07-03 18:28:31	6000	701	0:00:02	0:00:02		
6	2013-07-03 18:28:06	6000	5001	0:00:22	0:00:20		
7	2013-07-03 18:27:47	6000	5001	0:00:16	0:00:14		
8	2013-07-03 17:55:04	6000	5001	0:00:18	0:00:16		
9	2013-07-03 17:54:32	6000	5001	0:00:19	0:00:18		
10	2013-07-03 17:53:11	6000	6300	0:00:11	0:00:11		

[Delete All](#)
[Download Records](#)
[First](#)
[Prev](#)
[Next](#)
[Last](#)

Figure 100: Call Report

Users could perform the following operations on the call report.

- Sort**
 Click on the header of the column to sort by this category. For example, clicking on "Start Time" will sort the report according to start time. Clicking on "Start Time" again will reverse the order.
- Download Records**
 On the bottom of the page, click on "Download Records" button to export the report in .csv format.
- Delete All**
 On the bottom of the page, click on "Delete All" button to remove all the call report information.
- Play/Download/Delete Recording File (per entry)**
 If the entry has audio recording file for the call, the three icons on the most right column will be activated for users to select. In the following picture, the second entry has audio recording file for the call.

Click on to play the recording file; click on to download the recording file in .wav format; click on to delete the recording file (the call record entry will not be deleted).

2013-07-03 18:27:47	6000	5001	0:00:16	0:00:14		
2013-07-03 17:55:04	6000	5001	0:00:18	0:00:16		

Figure 101: Call Report Entry with Audio Recording File

DOWNLOADED CDR FILE

The downloaded CDR (.csv file) has different format from the web UI CDR. Here are some descriptions.

- **Call From, Call To**

"Call From": the caller ID.

"Call To": the callee ID.

If "Call From" shows empty, "Call To" shows "s" (see highlight part in the picture below) and the "Source Channel" contains "DAHDI", this means the call is from FXO/PSTN line. For FXO/PSTN line, we only know there is an incoming request when there is incoming call but we don't know the number being called. So we are using "s" to match it where "s" means "start".

call from	call to	context	start time	answer time	end time	call time	talk time	source channel	dest channel	status
610	19097622990	from-internal	1/29/2014 14:28	1/29/2014 14:28	1/29/2014 14:31	153	150	SIP/610-00000074	DAHDI/1-1	ANSWERED
	s	default	1/29/2014 14:33		1/29/2014 14:33	8	0	DAHDI/pseudo-149089967		NO ANSWER
	s	default	1/29/2014 14:33		1/29/2014 14:33	9	0	DAHDI/pseudo-1067045536		NO ANSWER
601	688	from-internal	1/29/2014 14:33	1/29/2014 14:33	1/29/2014 14:33	9	9	SIP/601-00000077		ANSWERED
	s	default	1/29/2014 14:34		1/29/2014 14:34	22	0	DAHDI/pseudo-1124093033		NO ANSWER
	s	default	1/29/2014 14:34		1/29/2014 14:34	22	0	DAHDI/pseudo-1719498666		NO ANSWER

Figure 102: Downloaded CDR File Sample - Call To Shows "s"

- **Context**

There are different context values that might show up in the downloaded CDR file. The actual value can vary case by case. Here are some sample values and their descriptions.

from-internal: internal extension makes outbound calls.

ext-did-XXXXX: inbound calls. It starts with "ext-did", and "XXXXX" content varies case by case, which also relate to the order when the trunk is created.

ext-local: internal calls between local extensions.

- **Source Channel, Dest Channel**

Sample 1:

call from	call to	context	start time	answer time	end time	call time	talk time	source channel	dest channel	status
3122731439	s	ext-did-1	1/30/2014 14:27	1/30/2014 14:27	1/30/2014 14:27	37	35	DAHDI/1-1		ANSWERED

Figure 103: Downloaded CDR File Sample - Source Channel and Dest Channel 1

DAHDI means it is an analog call, FXO or FXS.

For UCM6510, DAHDI/(1-2) are FXO ports, and DAHDI(3-4) are FXS ports.

For UCM6510, DAHDI/(1-4) are FXO ports, and DAHDI(5-6) are FXS ports.

For UCM6510, DAHDI/(1-8) are FXO ports, and DAHDI(9-10) are FXS ports.

For UCM6510, DAHDI/(1-16) are FXO ports, and DAHDI/(17-18) are FXS ports.

Sample 2:

call from	call to	context	start time	answer time	end time	call time	talk time	source channel	dest channel	status
609	619	from-internal	1/30/2014 14:31	1/30/2014 14:32	1/30/2014 14:32	9		3 SIP/609-00000150	SIP/619-00000151	ANSWERED

Figure 104: Downloaded CDR File Sample - Source Channel and Dest Channel 2

"SIP" means it's a SIP call. There are three possible format:

- (a) **SIP/NUM-XXXXXX**, where NUM is the local SIP extension number. The last XXXXX is a random string and can be ignored.
- (c) **SIP/trunk_X/NUM**, where trunk_X is the internal trunk name, and NUM is the number to dial out through the trunk.
- (c) **SIP/trunk_X-XXXXXX**, where trunk_X is the internal trunk name and it is an inbound call from this trunk. The last XXXXX is a random string and can be ignored.

Sample 3:

call from	call to	context	start time	answer time	end time	call time	talk time	source channel	dest channel	status
	s	default	1/30/2014 14:30		1/30/2014 14:37	386	0	DAHDI/pseudo-1665832080		NO ANSWER
	s	default	1/30/2014 14:30		1/30/2014 14:37	390	0	DAHDI/pseudo-1946772436		NO ANSWER

Figure 105: Downloaded CDR File Sample - Source Channel and Dest Channel 3

This is a very special channel name. If it shows up, most likely it means a conference call.

There are some other possible values, but these values are almost the application name which are used by the dialplan.

IAX2/NUM-XXXXXXX: it means this is an IAX call.

Local/@from-internal-XXXXX: it is used internally to do some special feature procedure. We can simply ignore it.

Hangup: the call is hung up from the dialplan. This indicates there are some errors or it has run into abnormal cases.

Playback: play some prompts to you, such as 183 response or run into an IVR.

ReadExten: collect numbers from user. It may occur when you input PIN codes or run into DISA

STATISTICS

CDR Statistics is an additional feature on the UCM6510 which provides users a visual overview of the call report across the time frame. Users can filter with different criteria to generate the statistics chart.

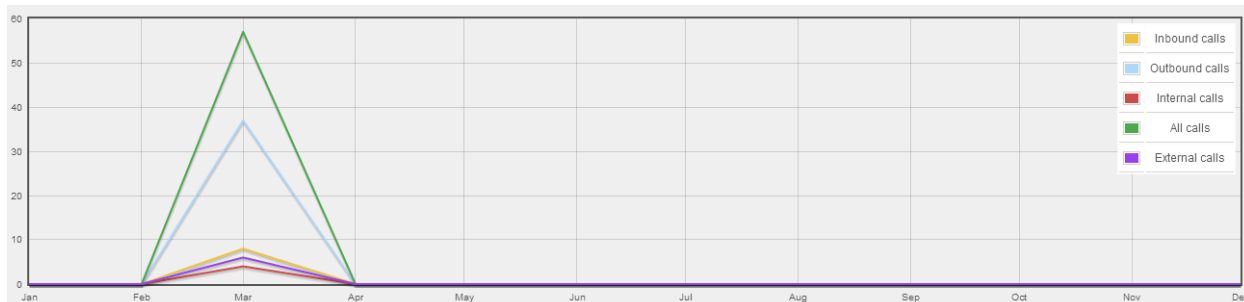





Figure 106: CDR Statistics

Table 73: CDR Statistics Filter Criteria

Trunk Type	Select one of the following trunk type. <ul style="list-style-type: none"> • All • SIP Calls • PSTN Calls • ISDN Calls
Call Type	Select one or more in the following checkboxes. <ul style="list-style-type: none"> • Inbound calls • Outbound calls • Internal calls • External calls • All calls
Time Range	<ul style="list-style-type: none"> • By month (of the selected year). • By week (of the selected year). • By day (of the specified month for the year). • By hour (of the specified date). • By range. For example, 2013-01 To 2013-03.

RECORDING FILES

The recording files recorded by "Auto Record" per extension/per trunk, or via feature code "Audio Mix Record" are listed here. Users could click on  to play the recording file; click on  to download the recording file in .wav format; or click on  to delete the recording file.

To sort the recording file, click on the title "Caller", "Callee" or "Call Time" for the corresponding column. Click on the title again can switch the sorting mode between ascending order or descending order.

CDR API CONFIGURATION FILES

The UCM6510 supports third party billing interface API for external billing software to access CDR on the PBX. The API uses HTTPS to request the CDR data matching given parameters as configured on the third party application. Before accessing the API, the administrators need enable API and configure the access/authentication information on the UCM6510 first.

Table 74: CDR API Configuration Files

Enable	Enable/Disable CDR API. The default setting is disabled.
TLS Bind Address	Configure the IP address for TLS server to bind to. "0.0.0.0" means binding to all interfaces. The port number is optional and the default port number is 8443. The IP address must match the common name (host name) in the certificate so that the TLS socket won't bind to multiple IP addresses. The default setting is 0.0.0.0:8443.
TLS Private Key	Upload TLS private key. The size of the key file must be under 2MB. This file will be renamed as 'private.pem' automatically.
TLS Cert	Upload TLS cert. The size of the certificate must be under 2MB. This is the certificate file (*.pem format only) for TLS connection. This file will be renamed as "certificate.pem" automatically. It contains private key for the client and signed certificate for the server.
TLS Authentication Name	Configure the user name for TLS authentication. If not configured, authentication will be skipped.
TLS Authentication Password	Configure the password for TLS authentication. This is optional.
Permitted	Specify a list of IP addresses permitted by CDR API. This creates an AIP-specific access control list. Multiple entries are allowed. For example, "192.168.40.3/255.255.255.255" denies access from all IP addresses except 192.168.40.3.

The format of the HTTPS request for the CDR API is as below.

https://[UCM IP]:[Port]/cdrapi?[option1]=[value]&[option2]=[value]&...

By default, the port number for the API is 8443.

The options included in the request URI control the record matching and output format. For CDR matching parameters, all non-empty parameters must have a match to return a record. Parameters can appear in the URI in any order. Multiple values given for caller or callee will be concatenated. The following table shows the parameter list used in the CDR API.

Table 75: CDR API URI Parameters

Field	Value	Details
format	csv, xml, json	Define the format for output of matching CDR rows. Default is csv (comma separated values).
numRecords	Number: 0-1000	Number of records to return. Default is 1000, which is also the maximum allowed value.
offset	Number	Number of matching records to skip. This will be combined with numRecords to receive all matches over multiple responses. Default is 0.
caller	Comma separated extensions, ranges of extensions, or regular expressions.	Filters based on src (caller) or dst (callee) value, matching any extension contained in the parameter input string.
callee	<p>Example:</p> <p>caller=5300,5302-5304,_4@</p> <p>-OR-</p> <p>caller=5300&caller=5302-5304&caller=_4@</p> <p>(Matches extensions 5300, 5302, 5303, 5304, and any extension containing 4 as the second digit/character).</p>	<p>Patterns containing one or more wildcards ('@' or '_') will match as a regular expression, and treat '-' as a literal hyphen rather than a range signifier. The '@' wildcard matches any number of characters (including zero), while '_' matches any single character. Otherwise, patterns containing a single hyphen will be matching a range of numerical extensions, with non-numerical characters ignored, while patterns containing multiple hyphens will be ignored. (The pattern "0-0" will match all non-numerical and empty strings).</p>
startTime	Date and/or time of day in any of the following formats:	Filters based on the start (call start time) value. Calls which start within this period (inclusive of boundaries) will match, regardless of the call answer or end time. An empty value for either field will be interpreted as range with no minimum or maximum respectively.
endTime	<p>YYYY-MM-DDTHH:MM</p> <p>YYYY-MM-DDTHH:MM:SS</p> <p>YYYY-MM-DDTHH:MM:SS.SSS</p> <p>(literal 'T' character separator in above three formats)</p>	
		Strings without a date have a default value of 2000-01-01. Strings without a time of day have a default value of 00:00 UTC, while strings with a time of day specified may also optionally specify a time zone offset - replace '+' in time zone offset with '%2B' (see

	HH:MM HH:MM:SS HH:MM:SS.SSS now DDDDDDDDDD	http://www.w3.org/TR/NOTE-datetime .
minDur	Number (duration in seconds)	Filters based on the billsec value, the duration between call answer and call end.
maxDur		

Example Queries:

The following illustrates the format of queries to accomplish certain requests. In most cases, multiple different queries will accomplish the same goal, and these examples are not intended to be exhaustive, but rather to bring attention to particular features of the CDR API connector.

Query 1: Request all records of calls placed on extension 5300 which last between 8 and 60 seconds (inclusive), with results in CSV format.

https://192.168.254.200:8088/cdrapi?format=CSV&caller=5300&minDur=8&maxDur=60

-OR-

https://192.168.254.200:8088/cdrapi?caller=5300&minDur=8&maxDur=60

Query 2: Request all records of calls placed on extension 5300 or in the range 6300-6399 to extensions starting with 5, with results in XML format.

https://192.168.254.200:8088/cdrapi?format=XML&caller=5300,6300-6399&callee=5@

-OR-

https://192.168.254.200:8088/cdrapi?cdrapi?format=XML&caller=5300&caller=6300-6399&callee=5@

Query 3: Request all records of calls placed on extensions containing substring "53" prior to January 23, 2013 00:00:00 UTC to extensions 5300-5309, with results in CSV format.

<https://192.168.254.200:8088/cdrapi?caller=@53@&callee=5300-5309&endTime=2013-01-23>

-OR-

https://192.168.254.200:8088/cdrapi?caller=@53@&callee=530_&endTime=2013-01-23T00:00:00

Query 4: Request all records of calls placed by an Anonymous caller during July 2013 Central Standard Time to extensions starting with 2 or 34 or ending with 5, with results in CSV format.

<https://192.168.254.200:8088/cdrapi?caller=Anonymous&callee=2@,34@,@5&startTime=2013-07-01T00:00:00-06:00&endTime=2013-07-31T23:59:59-06:00>

Query 5: Request all records during July 2013 Central Standard Time, 200 at a time, with results in CSV format.

<https://192.168.254.200:8088/cdrapi?startTime=2013-07-01T00:00:00-06:00&endTime=2013-07-31T23:59:59-06:00&numRecords=200&offset=0>

-THEN-

<https://192.168.254.200:8088/cdrapi?sstartTime=2013-07-01T00:00:00-06:00&endTime=2013-07-31T23:59:59-06:00&numRecords=200&offset=200>

-THEN-

<https://192.168.254.200:8088/cdrapi?startTime=2013-07-01T00:00:00-06:00&endTime=2013-07-31T23:59:59-06:00&numRecords=200&offset=400>

 **Note:**

- Disallowed characters in the caller, callee, startTime, or endTime strings, and non-digit characters in the values of numRecords, offset, minDur, or maxDur, will result in no records returned - the appropriate container/header for the output format will be the only output. If the format parameter is in error, the CSV header will be used. Error messages will appear in the Asterisk log (along with errors stemming from failed database connections, etc.).
- Other errors which return no records include:
 - Multiple hyphens in an extension range (e.g. caller=5300-5301-,6300)
 - Empty parameter value (e.g. caller=)
 - Extension values starting with comma, or with consecutive commas (e.g. caller=5300,,5303)
 - Unknown parameters (e.g. caler=5300) or URI ending with '&'
 - Except for caller and callee, multiple instances of the same parameter within the URI (e.g. minDur=5&minDur=10)

Example Output:

The following are examples of each of the output formats for the same data set.

CSV:

```
AcctId,accountcode,src,dst,dcontext,clid,channel,dstchannel,lastapp,lastdata,start,answer,end,duration,
billsec,disposition,amaflags,uniqueid,userfield,channel_ext,dstchannel_ext,service
62,,5300,5301,from-internal,"pn01" <5300>,SIP/5300-00000000,SIP/5301-
00000001,Dial,SIP/5301,60,,2013-12-03 11:46:40,2013-12-03 11:46:43,2013-12-03
11:46:49,9,6,ANSWERED,DOCUMENTATION,1386092800.0,EXT,5300,5301,s
63,,5300,5301,from-internal,"pn01" <5300>,SIP/5300-00000000,SIP/5301-
00000001,Dial,SIP/5301,60,,2013-12-03 14:01:41,2013-12-03 14:01:43,2013-12-03
14:01:46,5,3,ANSWERED,DOCUMENTATION,1386100901.0,EXT,5300,5301,s
64,,5300,5301,from-internal,"pn01" <5300>,SIP/5300-00000002,SIP/5301-
00000003,Dial,SIP/5301,60,,2013-12-03 14:02:23,2013-12-03 14:02:27,2013-12-03
14:02:31,8,4,ANSWERED,DOCUMENTATION,1386100943.2,EXT,5300,5301,s
```

XML:

```

<root>
<cdr><AcctId>62</AcctId><accountcode></accountcode><src>5300</src><dst>5301</dst><dcontext>
from-internal</dcontext><clid>&quot;pn01&quot; &lt;5300&gt;</clid><channel>SIP/5300-
00000000</channel><dstchannel>SIP/5301-
00000001</dstchannel><lastapp>Dial</lastapp><lastdata>SIP/5301,60,</lastdata><start>2013-12-03
11:46:40</start><answer>2013-12-03 11:46:43</answer><end>2013-12-03
11:46:49</end><duration>9</duration><billsec>6</billsec><disposition>ANSWERED</disposition><a
maflags>DOCUMENTATION</amaflags><uniqueid>1386092800.0</uniqueid><userfield>EXT</userfie
ld><channel_ext>5300</channel_ext><dstchannel_ext>5301</dstchannel_ext><service>s</service></
cdr>
<cdr><AcctId>63</AcctId><accountcode></accountcode><src>5300</src><dst>5301</dst><dcontext>
from-internal</dcontext><clid>&quot;pn01&quot; &lt;5300&gt;</clid><channel>SIP/5300-
00000000</channel><dstchannel>SIP/5301-
00000001</dstchannel><lastapp>Dial</lastapp><lastdata>SIP/5301,60,</lastdata><start>2013-12-03
14:01:41</start><answer>2013-12-03 14:01:43</answer><end>2013-12-03
14:01:46</end><duration>5</duration><billsec>3</billsec><disposition>ANSWERED</disposition><a
maflags>DOCUMENTATION</amaflags><uniqueid>1386100901.0</uniqueid><userfield>EXT</userfie
ld><channel_ext>5300</channel_ext><dstchannel_ext>5301</dstchannel_ext><service>s</service></
cdr>
<cdr><AcctId>64</AcctId><accountcode></accountcode><src>5300</src><dst>5301</dst><dcontext>
from-internal</dcontext><clid>&quot;pn01&quot; &lt;5300&gt;</clid><channel>SIP/5300-
00000002</channel><dstchannel>SIP/5301-
00000003</dstchannel><lastapp>Dial</lastapp><lastdata>SIP/5301,60,</lastdata><start>2013-12-03
14:02:23</start><answer>2013-12-03 14:02:27</answer><end>2013-12-03
14:02:31</end><duration>8</duration><billsec>4</billsec><disposition>ANSWERED</disposition><a
maflags>DOCUMENTATION</amaflags><uniqueid>1386100943.2</uniqueid><userfield>EXT</userfie
ld><channel_ext>5300</channel_ext><dstchannel_ext>5301</dstchannel_ext><service>s</service></
cdr>
</root>

```

JSON:

```

{
  "cdr":
  [
    { "AcctId": "62", "accountcode": "", "src": "5300", "dst": "5301", "dcontext": "from-internal", "clid":
    "\"pn01\" <5300>", "channel": "SIP/5300-00000000", "dstchannel": "SIP/5301-00000001", "lastapp":
    "Dial", "lastdata": "SIP/5301,60,", "start": "2013-12-03 11:46:40", "answer": "2013-12-03 11:46:43",
    "end": "2013-12-03 11:46:49", "duration": "9", "billsec": "6", "disposition": "ANSWERED", "amaflags":
    "DOCUMENTATION", "uniqueid": "1386092800.0", "userfield": "EXT", "channel_ext": "5300",
    "dstchannel_ext": "5301", "service": "s" },
    { "AcctId": "63", "accountcode": "", "src": "5300", "dst": "5301", "dcontext": "from-internal", "clid":
    "\"pn01\" <5300>", "channel": "SIP/5300-00000000", "dstchannel": "SIP/5301-00000001", "lastapp":
    "Dial", "lastdata": "SIP/5301,60,", "start": "2013-12-03 14:01:41", "answer": "2013-12-03 14:01:43",
    "end": "2013-12-03 14:01:46", "duration": "5", "billsec": "3", "disposition": "ANSWERED", "amaflags":
    "DOCUMENTATION", "uniqueid": "1386100901.0", "userfield": "EXT", "channel_ext": "5300",
    "dstchannel_ext": "5301", "service": "s" },
    { "AcctId": "64", "accountcode": "", "src": "5300", "dst": "5301", "dcontext": "from-internal", "clid":
    "\"pn01\" <5300>", "channel": "SIP/5300-00000002", "dstchannel": "SIP/5301-00000003", "lastapp":
    "Dial", "lastdata": "SIP/5301,60,", "start": "2013-12-03 14:02:23", "answer": "2013-12-03 14:02:27",
    "end": "2013-12-03 14:02:31", "duration": "8", "billsec": "4", "disposition": "ANSWERED", "amaflags":
    "DOCUMENTATION", "uniqueid": "1386100943.2", "userfield": "EXT", "channel_ext": "5300",
    "dstchannel_ext": "5301", "service": "s" }
  ]
}

```

UPGRADING AND MAINTENANCE

UPGRADING

The UCM6510 can be upgraded to a new firmware version remotely or locally. This section describes how to upgrade your UCM6510 via network or local upload.

UPGRADING VIA NETWORK

The UCM6510 can be upgraded via TFTP/HTTP/HTTPS by configuring the URL/IP Address for the TFTP/HTTP/HTTPS server and selecting a download method. Configure a valid URL for TFTP, HTTP or HTTPS; the server name can be FQDN or IP address.

Examples of valid URLs:

firmware.grandstream.com

The upgrading configuration can be accessed via **web GUI->Maintenance->Upgrade**.

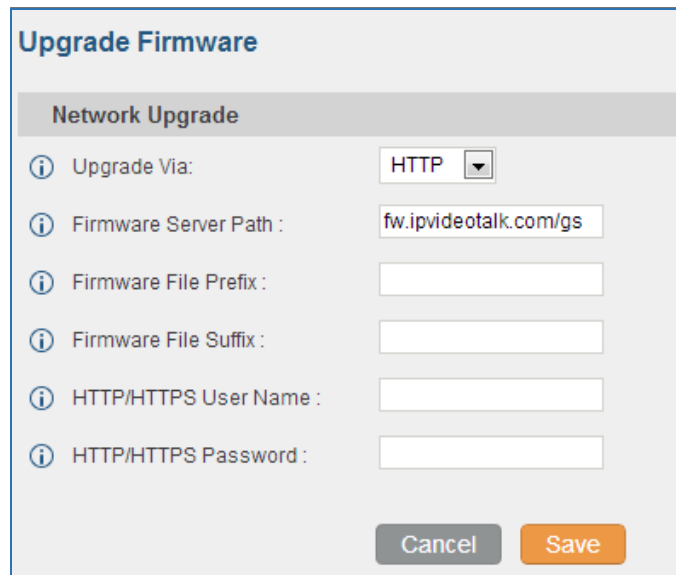

The screenshot shows a web interface titled "Upgrade Firmware". Under the "Network Upgrade" section, there are several configuration fields:

- Upgrade Via:** A dropdown menu set to "HTTP".
- Firmware Server Path:** A text input field containing "fw.ipvideotalk.com/gs".
- Firmware File Prefix:** An empty text input field.
- Firmware File Suffix:** An empty text input field.
- HTTP/HTTPS User Name:** An empty text input field.
- HTTP/HTTPS Password:** An empty text input field.

At the bottom right of the form, there are two buttons: "Cancel" (grey) and "Save" (orange).

Figure 107: Network Upgrade

Table 76: Network Upgrade Configuration

Upgrade Via	Allow users to choose the firmware upgrade method: TFTP, HTTP or HTTPS.
Firmware Server Path	Define the server path for the firmware server.
Firmware File Prefix	If configured, only the firmware with the matching encrypted prefix will be downloaded and flashed into the UCM6510.
Firmware File Suffix	If configured, only the firmware with the matching encrypted postfix will be downloaded and flashed into the UCM6510.
HTTP/HTTPS User Name	The user name for the HTTP/HTTPS server.
HTTP/HTTPS Password	The password for the HTTP/HTTPS server.

Please follow the steps below to upgrade the firmware remotely.

- Enter the firmware server path under **web GUI->Maintenance->Upgrade**.
- Click on "Save". Then reboot the device to start the upgrading process.
- Please be patient during the upgrading process. Once done, a reboot message will be displayed in the LCD.
- Manually reboot the UCM6510 when it's appropriate to avoid immediate service interruption. After it boots up, log in the web GUI to check the firmware version.

UPGRADING VIA LOCAL UPLOAD

If there is no HTTP/TFTP server, users could also upload the firmware to the UCM6510 directly via web GUI. Please follow the steps below to upload firmware locally.

1. Download the latest UCM6510 firmware file from the following link and save it in your PC.
<http://www.grandstream.com/support/firmware>
2. Log in the web GUI as administrator in the PC.
3. Go to web GUI->**Maintenance->Upgrade**, upload the firmware file by clicking on  and select the firmware file from your PC. The default firmware file name is ucm6510fw.bin

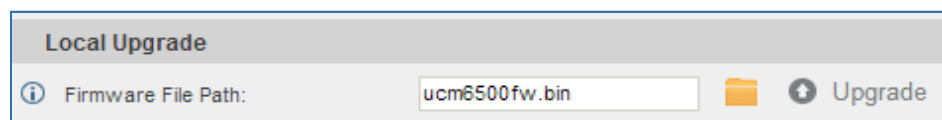

Figure 108: Local Upgrade

- Click on  to start upgrading.

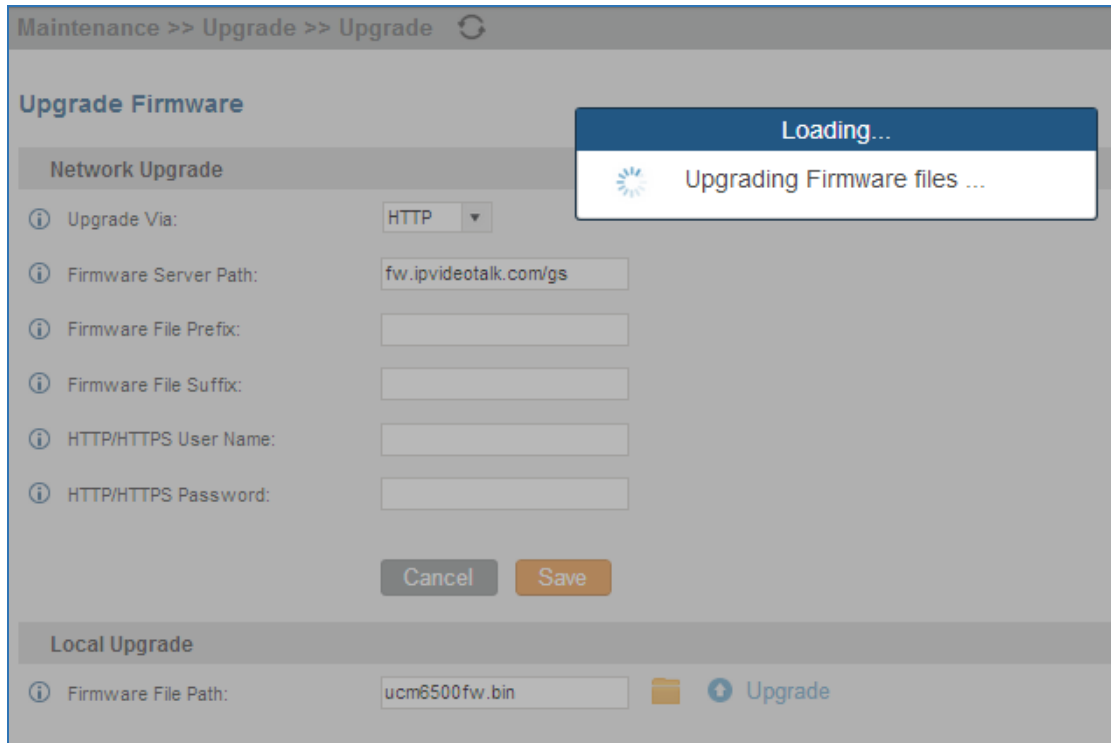

Figure 109: Upgrading Firmware Files

- Wait until the upgrading process is successful and a window will be popped up in the web GUI.

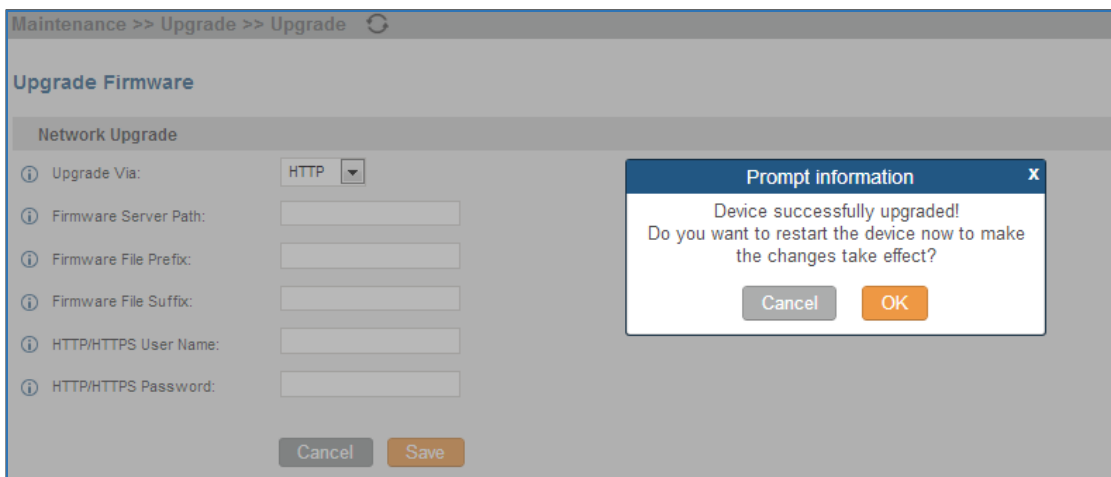

Figure 110: Reboot UCM6510

- Click on "OK" to reboot the UCM6510 and check the firmware version after it boots up.

 **Note:**

Please do not interrupt or power cycle the UCM6510 during upgrading process.

NO LOCAL FIRMWARE SERVERS

For users that would like to use remote upgrading without a local TFTP server, Grandstream offers a NAT-friendly HTTP server. This enables users to download the latest software upgrades for their devices via this server. Please refer to the webpage:

<http://www.grandstream.com/support/firmware>.

Alternatively, users can download a free TFTP or HTTP server and conduct a local firmware upgrade. A free windows version TFTP server is available for download from:

http://www.solarwinds.com/products/freetools/free_tftp_server.aspx

<http://ftpd32.jounin.net>

Instructions for local firmware upgrade via TFTP:

1. Unzip the firmware files and put all of them in the root directory of the TFTP server;
2. Connect the PC running the TFTP server and the UCM6510 to the same LAN segment;
3. Launch the TFTP server and go to the File menu->Configure->Security to change the TFTP server's default setting from "Receive Only" to "Transmit Only" for the firmware upgrade;
4. Start the TFTP server and configure the TFTP server in the UCM6510 web configuration interface;
5. Configure the Firmware Server Path to the IP address of the PC;
6. Update the changes and reboot the UCM6510.

End users can also choose to download a free HTTP server from <http://httpd.apache.org/> or use Microsoft IIS web server.



BACKUP

The UCM6510 configuration can be backed up locally or via network. The backup file will be used to restore the configuration on UCM6510 when necessary.

LOCAL BACKUP

Users could backup the UCM6510 configurations for restore purpose under web GUI->**Maintenance->Backup->Local Backup**. Before creating new backup file, select the backup option first.

- If the Config-File is selected only, the backup file will be saved in the flash of the UCM6510.
- If Voice-File, Voicemail-File, Voice-Records, CDR or VFAX is selected, external storage devices (USB Flash drive or SD Card) will be required because the backup file might be too large.

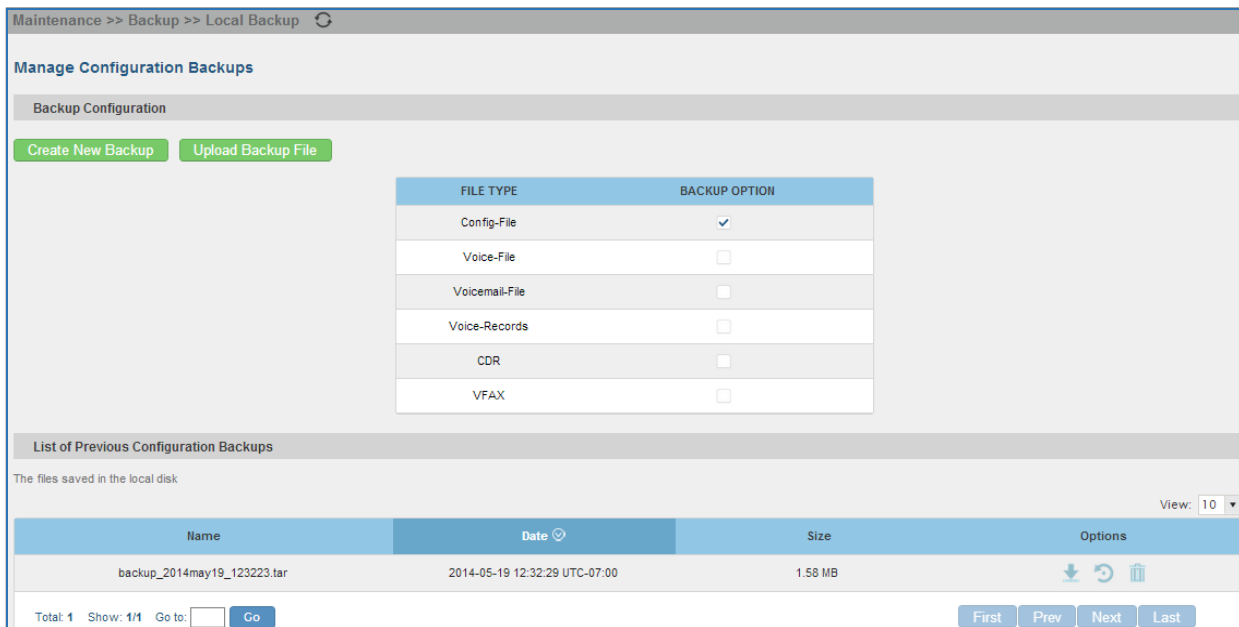

Click on "Create New Backup" button to start backup. Once the backup is done, the list of the backups will be displayed with date and time in the web page. Users can download , restore , or delete  it from the UCM6510 internal storage or the external device.



The screenshot shows the 'Manage Configuration Backups' interface. At the top, there are two buttons: 'Create New Backup' and 'Upload Backup File'. Below these is a table for selecting backup options:

FILE TYPE	BACKUP OPTION
Config-File	<input checked="" type="checkbox"/>
Voice-File	<input type="checkbox"/>
Voicemail-File	<input type="checkbox"/>
Voice-Records	<input type="checkbox"/>
CDR	<input type="checkbox"/>
VFAX	<input type="checkbox"/>

Below the table is a section titled 'List of Previous Configuration Backups' with the subtitle 'The files saved in the local disk'. It features a table with columns for Name, Date, Size, and Options. A single backup file is listed:

Name	Date	Size	Options
backup_2014may19_123223.tar	2014-05-19 12:32:29 UTC-07:00	1.58 MB	  

At the bottom, there are navigation controls including 'Total: 1', 'Show: 1/1', 'Go to: [input]', 'Go', and 'First', 'Prev', 'Next', 'Last' buttons.

Figure 111: Local Backup

DATA SYNC

Besides local backup, users could backup the voice records/voice mails/CDR/FAX in a daily basis to a remote server via SFTP protocol automatically under web GUI->**Maintenance->Backup->Data Sync**.

Manage Configuration Network Backups

Backup your voice records/voicemails/CDR/Fax every day via SFTP protocol automatically.

Backup Configuration

ⓘ Enable Backup:

ⓘ Account:

ⓘ Password: 🔍

ⓘ Server Address:

ⓘ Backup Time:

Figure 112: Data Sync

Table 77: Data Sync Configuration

Enable Backup	Enable the auto backup function. The default setting is "No".
Account	Enter the Account name on the SFTP backup server.
Password	Enter the Password associate with the Account on the SFTP backup server.
Server Address	Enter the SFTP server address.
Backup Time	Enter 0-23 to specify the backup hour of the day.

Before saving the configuration, users could click on "Test Connection". The UCM6510 will then try connecting the server to make sure the server is up and accessible for the UCM6510.

Save the changes and all the backup logs will be listed on the web page.

RESTORE CONFIGURATION FROM BACKUP FILE

To restore the configuration on the UCM6510 from a backup file, users could go to web GUI->**Maintenance->Backup->Local Backup**.

- A list of previous configuration backups is displayed on the web page. Users could click on  of the desired backup file and it will be restored to the UCM6510.
- If users have other backup files on PC to restore on the UCM6510, click on "Upload Backup File" first and select it from local PC to upload on the UCM6510. Once the uploading is done, this backup file

will be displayed in the list of previous configuration backups for restore purpose. Click on  to restore from the backup file.

Create New Backup
Upload Backup File

FILE TYPE	BACKUP OPTION
Config-File	<input checked="" type="checkbox"/>
Voice-File	<input type="checkbox"/>
Voicemail-File	<input type="checkbox"/>
Voice-Records	<input type="checkbox"/>
CDR	<input type="checkbox"/>

List of Previous Configuration Backups







No.	Name	Date	Options
1	backup_2013may14_232900	23:29:55 May 14, 2013	  
2	backup_2013mar26_180249	18:02:51 Mar 26, 2013	  

Figure 113: Restore UCM6510 from Backup File



Note:

- The uploaded backup file must be a tar file with no special characters like *,!,#,@,&,\$,%^,(,)/,\.space in the file name.
- The uploaded back file size must be under 10MB.

CLEANER

Users could configure to clean the Call Detail Report/Voice Records/Voice Mails/FAX automatically under web GUI->**Maintenance->Cleaner**.

CDR Cleaner

i Enable CDR Cleaner:

i CDR Clean Time:

i Clean Interval:

Voice Records Cleaner

i Enable VR Cleaner:

i VR Clean Threshold:

i VR Clean Time:

i VR Clean Interval:

Figure 114: Cleaner

Table 78: Cleaner Configuration

Enable CDR Cleaner	Enable the CDR Cleaner function.
CDR Clean Time	Enter 0-23 to specify the hour of the day to clean up CDR.
Clean Interval	Enter 1-30 to specify the day of the month to clean up CDR.
Enable VR Cleaner	Enable the Voice Records Cleaner function.
VR Clean Threshold	Specify the Voice Records threshold from 0 to 99 by using local storage status in percentage.
VR Clean Time	Enter 0-23 to specify the hour of the day to clean up Voice Records.
Clean Interval	Enter 1-30 to specify the day of the month to clean up Voice Records.

All the cleaner logs will be listed on the bottom of the page.

RESET AND REBOOT

Users could perform reset and reboot under web GUI->**Maintenance->Reset and Reboot**.

To factory reset the device, select the mode type first. There are two different types for reset.

- User Data: All the data including voicemail, recordings, IVR Prompt, Music on Hold, CDR and backup files will be cleared.
- All: All the configurations and data will be reset to factory default.

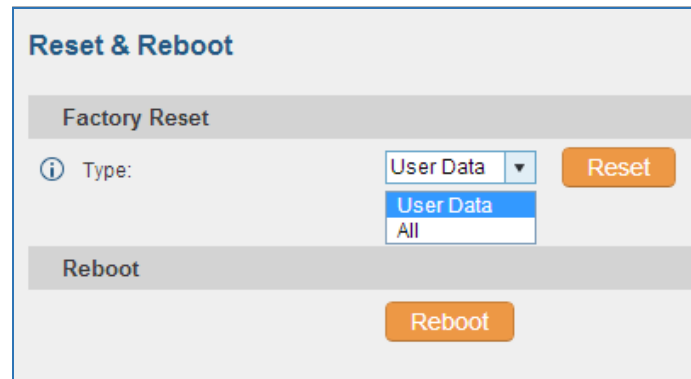

Figure 115: Reset and Reboot

SYSLOG

On the UCM6510, users could dump the syslog information to a remote server under web GUI->**Maintenance**->**Syslog**. Enter the syslog server hostname or IP address and select the module/level for the syslog information.

The default syslog level for all modules is "error", which is recommended in your UCM6510 settings because it can be helpful to locate the issues when errors happen.

Some typical modules for UCM6510 functions are as follows and users can turn on "notic" and "verb" levels besides "error" level.

pbx: This module is related to general PBX functions.

chan_sip: This module is related to SIP calls.

chan_dahdi: This module is related to analog calls (FXO/FXS).

app_meetme: This module is related to Conference Bridge.

 **Note:**

Syslog is usually for debugging and troubleshooting purpose. Turning on all levels for all syslog modules is not recommended for daily usage. Too many syslog print might cause traffic and affect system performance.

TROUBLESHOOTING

On the UCM6510, users could capture traces, ping remote host and traceroute remote host for troubleshooting purpose under web GUI->**Maintenance->Troubleshooting**.

ETHERNET CAPTURE

The captured trace can be downloaded for analysis. Also the instructions or result will be displayed in the web GUI output result.

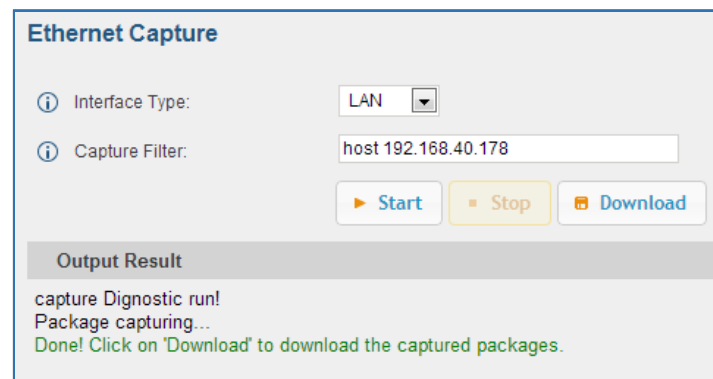

The screenshot shows a web interface titled "Ethernet Capture". It contains the following elements:

- Interface Type:** A dropdown menu currently set to "LAN".
- Capture Filter:** A text input field containing "host 192.168.40.178".
- Buttons:** Three buttons are located below the input fields: a blue "Start" button with a play icon, a yellow "Stop" button with a square icon, and a blue "Download" button with a download icon.
- Output Result:** A section with a grey header containing the text: "capture Dignostic run!
Package capturing...
Done! Click on 'Download' to download the captured packages."

Figure 116: Ethernet Capture

The output result is in .pcap format. Therefore, users could specify the capture filter as used in general network traffic capture tool (host, src, dst, net, protocol, port, port range) before starting capturing the trace.

IP PING

Enter the target host in host name or IP address. Then press "Start" button. The output result will dynamically display in the window below.

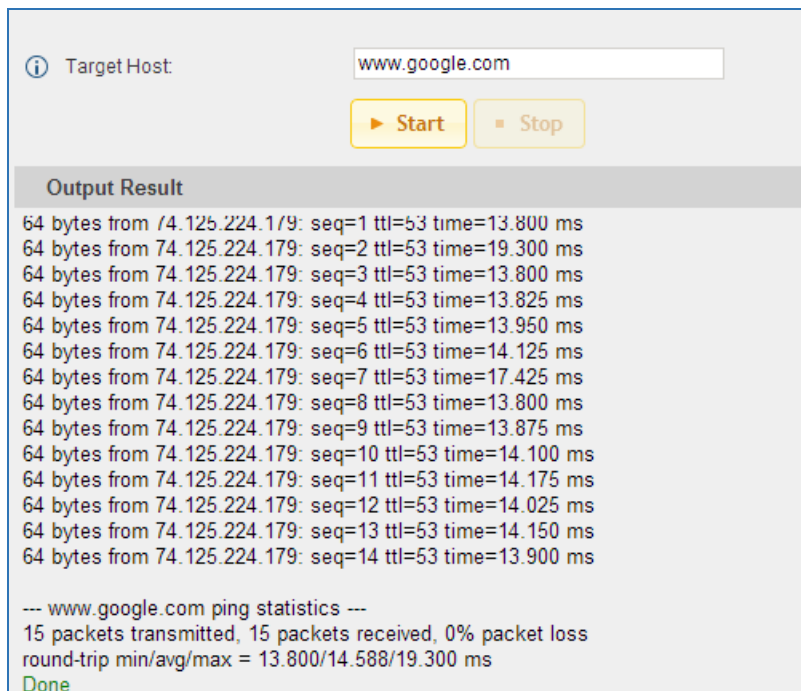

Figure 117: PING

TRACEROUTE

Enter the target host in host name or IP address. Then press "Start" button. The output result will dynamically display in the window below.

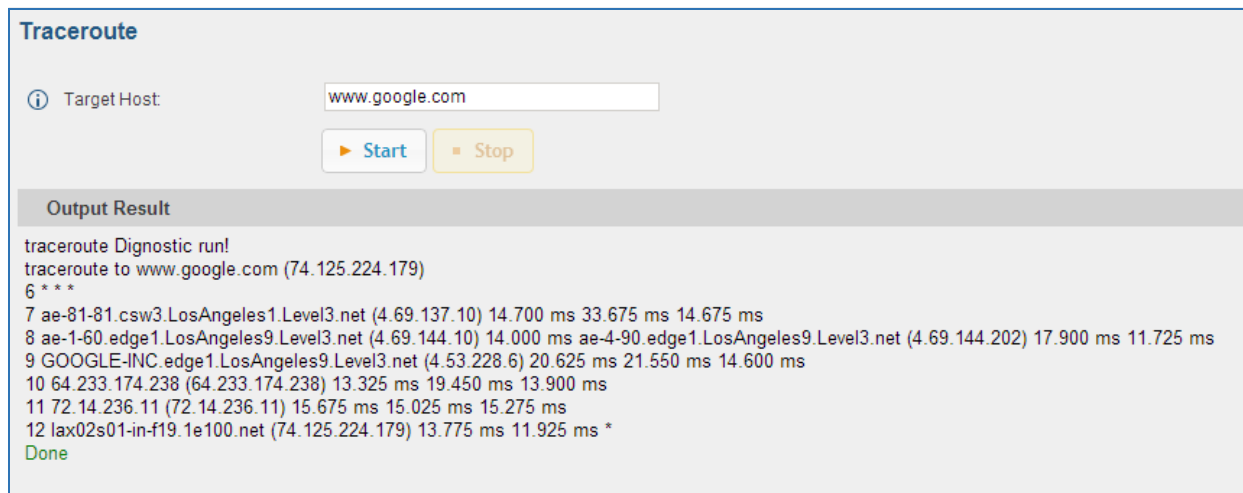

Figure 118: Traceroute

PRI/SS7/MFC/R2 SIGNALING TRACE

Please see section **[DIGITAL TRUNK TROUBLESHOOTING]**.

ANALOG RECORD TRACE

Analog record trace can be used to troubleshoot analog trunk issue, for example, the UCM6510 user has caller ID issue for incoming call from Analog trunk. Users can access analog record trace under web GUI->**Maintenance->Troubleshooting ->Analog Record Trace.**

Here is the step to capture trace:

1. Select FXO or FXS for "Record Ports". If the issue happens on FXO 1, select FXO port 1 to record the trace.
2. Select "Record Direction".
3. Select "Record File Mode" to separate the record per direction or mix.
4. Click on "Start".
5. Make a call via the analog port that has the issue.
6. Once done, click on "Stop".
7. Click on "Download" to download the analog record trace.

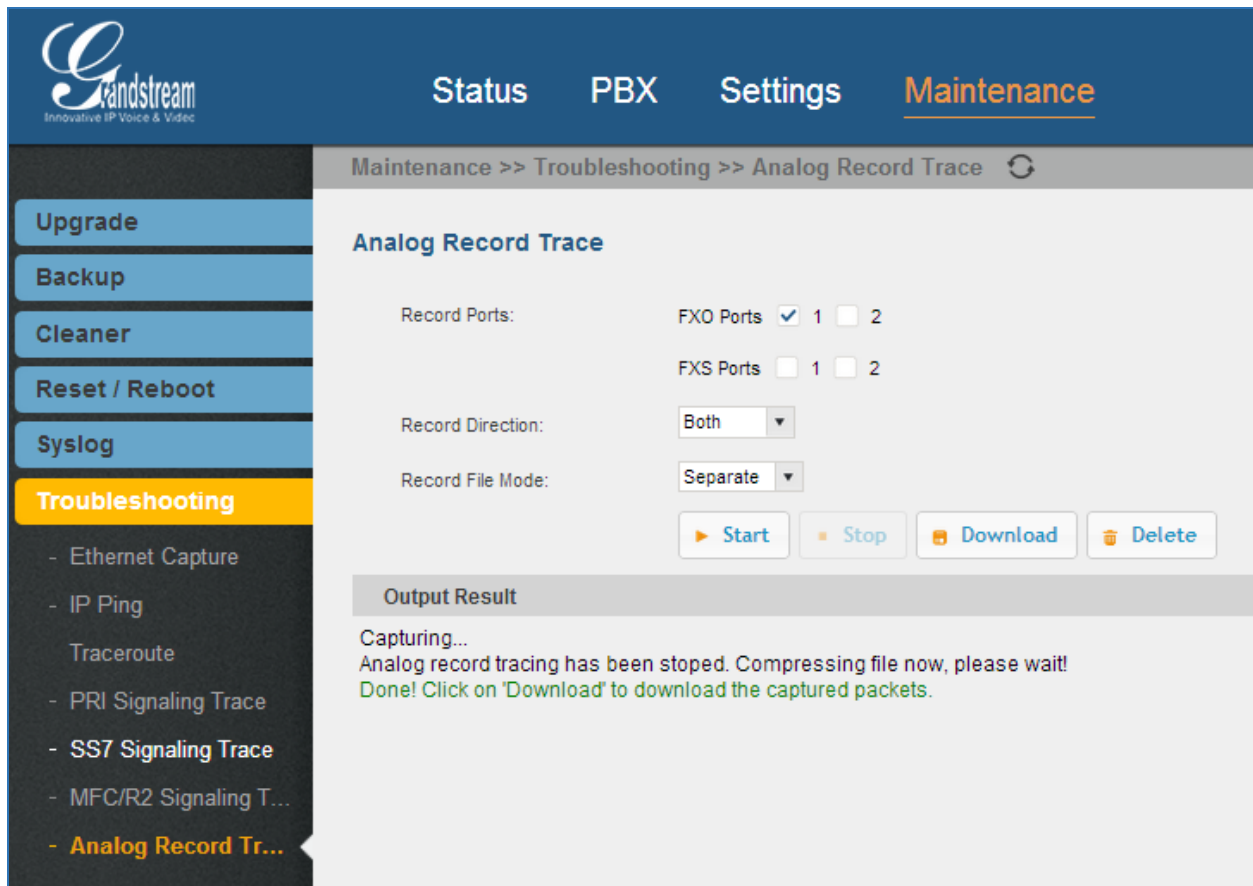

The screenshot shows the Grandstream PBX web interface. The top navigation bar includes 'Status', 'PBX', 'Settings', and 'Maintenance'. The left sidebar contains menu items: 'Upgrade', 'Backup', 'Cleaner', 'Reset / Reboot', 'Syslog', and 'Troubleshooting'. Under 'Troubleshooting', there is a list of options: 'Ethernet Capture', 'IP Ping', 'Traceroute', 'PRI Signaling Trace', 'SS7 Signaling Trace', 'MFC/R2 Signaling T...', and 'Analog Record Tr...'. The main content area is titled 'Maintenance >> Troubleshooting >> Analog Record Trace'. It features a configuration section for 'Analog Record Trace' with the following settings: 'Record Ports' (FXO Ports checked for 1, FXS Ports unchecked for 1 and 2), 'Record Direction' (Both), and 'Record File Mode' (Separate). Below the configuration are buttons for 'Start', 'Stop', 'Download', and 'Delete'. The 'Output Result' section shows a message: 'Capturing... Analog record tracing has been stoped. Compressing file now, please wait! Done! Click on 'Download' to download the captured packets.'

Figure 119: Troubleshooting Analog Trunks

After capturing the trace, users can download it for basic analysis. Or you can contact Grandstream Technical support in the following link for further assistance if the issue is not resolved.

<http://www.grandstream.com/index.php/support>

This page intentionally left blank

EXPERIENCING THE UCM6510 SERIES IP PBX

Please visit our website: <http://www.grandstream.com> to receive the most up- to-date updates on firmware releases, additional features, FAQs, documentation and news on new products.

We encourage you to browse our [product related documentation](#), [FAQs](#) and [User and Developer Forum](#) for answers to your general questions. If you have purchased our products through a Grandstream Certified Partner or Reseller, please contact them directly for immediate support.

Our technical support staff is trained and ready to answer all of your questions. Contact a technical support member or [submit a trouble ticket online](#) to receive in-depth support.

Thank you again for purchasing Grandstream UCM6510 IP PBX appliance, it will be sure to bring convenience and color to both your business and personal life.

*** Asterisk is a Registered Trademark of Digium, Inc.**